



CAPRICORN DISTRICT MUNICIPALITY

BID NUMBER: INF-W02/2022/2023

**NAIRIN VILLAGE WATER SUPPLY IN THE BLOUBERG LOCAL MUNICIPALITY OF
CAPRICORN DISTRICT MUNICIPALITY – LIMPOPO PROVINCE**

6CEPE/7CE

TENDER DOCUMENT

THIS DOCUMENT IS COMPILED FOR:
CAPRICORN DISTRICT MUNICIPALITY
P.O BOX 4100
POLOKWANE
0700

Tel: +27 15 294 1000
Fax: +27 15 295 4010

Name of Bidder:			
Bid Amount Contract C (VAT Inclusive):			
BBBEE status:			
Bidder Address:			
CSD Supplier Number:			
Email Address:			
Contact numbers:	Cell:	Tel:	Fax:

Prepared by:
SADC PROJECT CONSULTING (PTY) LTD &
ORBITALS TRADING AND PROJECTS JV
Stand No 19A, Church Street, Polokwane
0700

Cell: 071 413 7467
E-mail: info@orbitals.co.za

mig | Municipal
Infrastructure
Grant



EXPANDED PUBLIC WORKS PROGRAMME
CONTRIBUTING TO A NATION AT WORK

Contents			
Number	Heading	Colour	Page
The Bid			
Part T1: Bidding procedure		White & Pink	
T1.1	Bid Notice and Invitation to Bid	White	3
T1.2	Bid Data	Pink	4 – 19
Part T2 : Returnable Documents		Yellow	
T2.1	List of Returnable Documents		20
T2.2	Returnable Schedules		20 – 61
The Contract			
Part C1 : Agreement and Contract Data		White	
C1.1	Form of Offer and Acceptance		62 - 65
C1.2	Contract Data		66 – 74
C1.3	Form of Guarantee		75 – 77
C1.4	Occupational Health and Safety		78 – 80
Part C2 : Special Conditions of Contract		Yellow	
C2.1	Special Conditions of Contract		81 – 87
Part C3 : Schedule of Quantities		Yellow	
C3.1	Preamble to Schedule of Quantities		88 – 92
C3.2	Schedule of Quantities		
Part C4 : Scope of Work		White	
C4.1	Scope of Work		93 – 102
C4.2	Drawing Descriptions		103
C4.3	Procurement		104
C4.4	Construction		105 – 109
C4.5	Management		110 – 112
Part C5 : Project Specification		Blue	
C5.1	Project Specification		113 – 159
Part C6 : OHS Specification for Construction Projects		White	
C6.1	Specification		160 – 171
Part C8 : Site Information		Green	
C8.1	Site Information		172 – 173
Part C7 : Drawings		White	
C7.1	Drawings		174 – 175



TENDER NOTICE AND INVITATION TO TENDER
CAPRICORN DISTRICT MUNICIPALITY
NAIRIN VILLAGE WATER SUPPLY IN THE BLOUBERG LOCAL MUNICIPALITY
TO BE IMPLEMENTED IN CAPRICORN DISTRICT MUNICIPALITY

BID NUMBER: INF-W02/2022/2023

Capricorn District Municipality, invites tenders for the construction of NAIRIN VILLAGE Water Supply situated within the Capricorn District Municipality which is situated in the Limpopo Province.

Tenders are hereby invited from only tenderers who can demonstrate that they will have in their employ staff which satisfy EPWP requirements during the contract validity are eligible to submit tenders. The minimum number of work opportunities expected to be created on this project is 49.

Only Tenderers that have a CIDB contractor grading of 6CEPE/7CE or higher are eligible to submit bids. Joint ventures are also eligible to submit bids provided every member of the Joint Venture is registered with the CIDB and a combined grade of the Joint Venture calculated in accordance with the construction industry development regulations is equal to or higher than a contractor grading of 6CEPE/7CE or higher.

Tender documents will be available during office hours as from the 25th of July 2022 from the office of the Capricorn District Municipality, 41 Biccard Street. A non-refundable cash tender deposit of 1573.00 is payable to secure a copy of the tender document. Queries relating to the issues of these documents may be addressed to Tiro Pilusa Tel No: (015) 294 1039, email pilusat@cdm.org.za.

Bids will be adjudicated in terms of the preferential procurement Policy Framework Act 5/2000 in consultation with the CIDB Act. Bids will remain valid for 90 days. Capricorn District Municipality reserves the right to negotiate further conditions and requirements with the successful bidder.

A compulsory clarification meeting will take place on the 02 August 2022 starting at 10H00. Prospective Tenderers are requested to meet the engineer at Capricorn District Municipality offices, (Blouberg Fire station. Senwabarwana).

Complete bid documents fully priced and signed sealed in an envelope marked "Bid Number. INF-W02/2022/2023, NAIRIN VILLAGEWATER SUPPLY" should be deposited in the Tender Box located in the foyer at the Capricorn District Municipality offices at 41 Biccard Street not later than 11h00 on the 23th of August 2022. Tenders will be opened in public immediately after the closing time referred to above. Telegraphic, e-mail or Tele-fax transmission and late tenders will not be accepted for consideration and where feasible shall be returned to the sender.

The Tenderer must have a staff member who has completed, or, is registered for training towards, the NQF level 5 unit standard "Develop and Promote Labour Intensive Construction Strategies".

Ramakuntwane Selepe
Municipal Manager

CAPRICORN DISTRICT MUNICIPALITY
41 Biccard Street, Polokwane
CONTRACT No.: INF-W02/2022/2023



CAPRICORN DISTRICT MUNICIPALITY

T1.2 Bid Data

The conditions of Bid are the Standard Conditions of Bid as contained in Annex F of the CIDB Standard for Uniformity in Construction Procurement. (See www.cidb.org.za) which are reproduced without amendment or alteration for the convenience of Bidders as an Annex to this Bid Data.

The Standard Conditions of Bid make several references to the Bid Data for details that apply specifically to this Bid. The Bid Data shall have precedence in the interpretation of any ambiguity or inconsistency between it and the standard conditions of Bid. Each item of data given below is cross-referenced to the clause in the Standard Conditions of Bid to which it mainly applies.

The additional conditions of Bid are:

Clause number	Bid Data
F.1.1	The employer is: Name : Capricorn District Municipality Address : P O Box 4100, Polokwane, 0700 Telephone : 015 294 1000 Fax : 015 295 4000
F.1.2	The Bid documents issued by the employer comprise: T1.1 Bid notice and invitation to Bid T1.2 Bid data T2.1 List of returnable documents T2.2 Returnable schedules Part 1: Agreements and contract data C1.1 Form of offer and acceptance C1.2 Contract data C1.3 Form of Guarantee C1.4 Occupational Health and Safety Part 2: Special Conditions of Contract C2.1 Special Conditions of Contract Part 3: Scope of work C3.1 Scope of work C3.2 Drawing Descriptions C3.3 Procurement C3.4 Construction C3.5 Management Part 4: Project Specification Part 5: Drawings Part 6: Site information Part 7: Schedule of Quantities C7.1 Preamble to Schedule of Quantities C7.2 Schedule of Quantities
F.1.4	The employer's agent is: SADC PROJECT CONSULTING (PTY) LTD & ORBITALS TRADING AND PROJECTS JV Stand No 19A, Church Street, Polokwane 0700 Cell: 071 413 7467 Email: info@orbitals.co.za
F.2.1	Only those tenderers who can demonstrate that they will have in their employ management and supervisory staff satisfying the requirement of the scope of work for labour-intensive competencies for supervisory and management staff during the validity of the contract are eligible to submit tenders.

F.2.1.1	Bidders are required to complete Schedule 3, Part 2 : Returnable with regard to similar work satisfactory out by the bidder.
F.2.1.2	<p>Only those Bidders who are registered with the CIDB, or are capable of being so prior to the evaluation of submissions, in a contractor grading designation equal to or higher than a contractor grading designation determined in accordance with the sum Bided for a 6CEPE/7 CE or higher class of construction work, are eligible to submit Bids. Joint ventures are eligible to submit Bids provided that:</p> <ol style="list-style-type: none"> 1. every member of the joint venture is registered with the CIDB; 2. the lead partner has a contractor grading designation in the 6CEPE/7 CE or higher class of construction work; and 3. the combined contractor grading designation calculated in accordance with the Construction Industry Development Regulations is equal to or higher than a contractor grading designation determined in accordance with the sum Bided for a 6CEPE/7 CE or higher class of construction work.
F.2.1	<p>The following Bidders who are registered with the CIDB, or are capable of being so registered prior to the evaluation of submissions, are eligible to submit Bids:</p> <ol style="list-style-type: none"> a) contractors who have a contractor grading designation equal to or higher than a contractor grading designation determined in accordance with the sum Bided for a 6CEPE/7 CE or higher class of construction work; and b) contractors registered as potentially emerging enterprises with the CIDB who are registered in one contractor grading designation lower than that required in terms of a) above and who satisfy the following criteria: <ol style="list-style-type: none"> i) The Department, following an interview with the management of the enterprise, is satisfied that the enterprise has the potential to develop and qualify to be registered in a higher contractor grading designation; and ii) The Department, following a risk assessment, is able to provide the necessary supportive measures required to enable the enterprise to successfully execute the contract. <p>Joint ventures are eligible to submit Bids provided that:</p> <ol style="list-style-type: none"> 1. every member of the joint venture is registered with the CIDB; 2. the lead partner has a contractor grading designation in the 6CEPE/7CE or higher class of construction work; and 3. the combined contractor grading designation calculated in accordance with the Construction Industry Development Regulations is equal to or higher than a contractor grading designation determined in accordance with the sum Bided for a 6CEPE/7CE or higher class of construction work.
F2.2	In order to be considered for an appointment in terms of this bid, it will be beneficial if the bidder have an office in the Capricorn District Municipality area, through which all communication with the employer will flow, and where the majority of work in terms of this bid will be carried out. The address of the local office must be indicated on Schedule 1, Part T2: returnable documents and which will be regarded as the domicilium citandi et executandi for the purposes of any contract arising from this bid submission. The bidder must attach a certified copy of the certificate of incorporation and shareholders certificate of his/her company, close corporation or trust to Schedule 2, Part T2:Returnable document
F.2.3	The tenderer is required to complete his/ her tender in full using a black ink. The tenderer is required to initial all pages of the bid document. Failure to complete the form of offer in full is an automatic disqualification. Other contraventions also constitute an incomplete tender and may result in the bid being disqualified.
F.2.7	The arrangements for a compulsory clarification meeting are as stated in the Bid Notice and Invitation to Bid. Bidders must sign the attendance list in the name of the Bidding entity. Addenda will be issued to and Bids will be received only from those Bidding entities appearing on the attendance list.
F.2.11	Do not make any alterations or additions to the bid documents, except to comply with the instructions issued by employer, or necessary to correct errors made by the bidder. All signatories to the bid offer shall initial all alterations. Erasure and the use of masking fluid are prohibited.

F.2.12	<p>No alternative Bid offers will be considered</p> <p>If a Bidder wishes to submit an alternative Bid offer, the only criteria permitted for such alternative Bid offer is that it demonstrably satisfies the Employer's standards and requirements, the details of which may be obtained from the Employer's Agent.</p> <p>Calculations, drawings and all other pertinent technical information and characteristics as well as modified or proposed Pricing Data must be submitted with the alternative Bid offer to enable the Employer to evaluate the efficacy of the alternative and its principal elements, to take a view on the degree to which the alternative complies with the Employer's standards and requirements and to evaluate the acceptability of the pricing proposals. Calculations must be set out in a clear and logical sequence and must clearly reflect all design assumptions. Pricing Data must reflect all assumptions in the development of the pricing proposal.</p> <p>Acceptance of an alternative Bid offer will mean acceptance in principle of the offer. It will be an obligation of the contract for the Bidder, in the event that the alternative is accepted, to accept full responsibility and liability that the alternative offer complies in all respects with the Employer's standards and requirements.</p> <p>The modified Pricing Data must include an amount equal to 5% of the amount Bided for the alternative offer to cover the Employer's costs of confirming the acceptability of the detailed design before it is constructed.</p>
F.2.13.2	Return all returnable documents to the employer after completing them in their entirety, by hand in non-erasable black ink
F.2.13.3	Parts of each Bid offer communicated on paper shall be submitted as original.
F.2.13.5 F2.15.1	<p>The employer's address for delivery of Bid offers and identification details to be shown on each Bid offer package are:</p> <p>Location of Bid box : Tender Box Physical address :41 Biccard Street Identification Details: Contract. INF-W02/2022/2023, NAIRIN VILLAGE Water Supply Postal address: P.O Box 4100, Polokwane, 0700</p>
F.2.13.6	A two-envelope procedure will not be followed.
F.2.15	The closing time for submission of Bid offers is as stated in the Bid Notice and Invitation to Bid.
F.2.15.1	Telephonic, telegraphic, telex, facsimile or e-mailed Bid offers will not be accepted.
F.2.16	The Bid offer validity period is 90 days; the municipality reserve the right to request an extension of the validity period if deemed necessary.
F.2.17	A bid may be rejected as non-responsive if the bidder fails to provide any clarification requested by the employer within the time for submission stated in the employer's written request.
F.2.18	The tenderer must submit to the Employer, names of all management and supervisory staff that will be employed to supervise the labour-intensive portion of the works together with satisfactory evidence that such staff members satisfy the eligibility requirements.
F.2.19	Access shall be provided for inspections, tests and analysis.
F.2.23	<p>The Bidder is required to submit with his Bid a Certificate of Contractor Registration issued by the Construction Industry Development Board and a copy of an original valid Tax Clearance Certificate issued by the South African Revenue Services or</p> <ul style="list-style-type: none"> • The electronic verification tax clearance must be accompanied by the verification code • The proof of CSD registration report must be attached <p>Where a Bidder satisfies CIDB contractor grading designation requirements through joint venture formation, such Bidders must submit the Certificates of Contractor Registration in respect of each partner.</p>
F.3.4.1	Bids will be opened immediately after the closing time for Bids at Municipal Offices, at 41 Biccard Street, Polokwane.

The procedure for the evaluation of responsive Bids is Method 2

The financial offer will be scored using Formula 2 (option 1) where the value of W1 is:

1) 90 where the financial value inclusive of VAT of all responsive Bids received have a value in excess of R 50 000 000.00; or

2) 80 where the financial value inclusive of VAT of one or more responsive Bid offers equals or is less than R 50 000 000.00.

Up to 100 minus W₁ Bid evaluation points will be awarded to Bidders who complete the preference schedule and who are found to be eligible for the preference claimed.

F.3.11 Evaluation of Bid offers

General

Step 1
Bidders will firstly be evaluated on their responsiveness.
This includes the following

1. Valid Tax Clearance Certificate /The electronic verification tax clearance must beaccompanied by the verification code(The proof of CSD registration report mustbe attached)
2. Attended Compulsory Site meeting
3. Authority of Signatory
4. Signing of Form of Offer
5. BOQ filled in using a black pen
6. Alterations signed
7. CIDB grading
8. List of Returnable documents as listed on T2.1
9. Municipal rates and taxes
10. Initials on all pages of tender document including drawings

Step 2
According to the MFMA Circular No. 53 of the Municipal Finance Act No. 56 of 2003. Bidders will firstly be evaluated on Functionality. The minimum Score for functionality is 70. Only the qualifying Tenderers will be evaluated on Method 2.
The following is the criteria that the Bidders will be evaluated for Functionality:

FUNCTIONALITY COMPETENCE ACHIEVEMENT SCHEDULES

TABLE A1: COMPANY EXPERIENCE (EXPERIENCE IN SIMILAR PROJECTS)

	TARGETED GOALS Name reference with contact details	TENDERED GOAL	POINTS CLAIMED BY TENDERER	ALLOCATED POINTS
1	More than 5 projects	20		
2	2 -4 projects	10		
3	1 project	5		
4	MAXIMUM POINTS	20		

N.B: TENDERERS TO SUBMIT NAMES COMPLETE WITH VALID CONTACT DETAILS. ATTACH APPOINTMENT LETTERS AND COMPLETION CERTIFICATES FOR THE LISTED PROJECTS. NON-SUBMISSION WILL RESULT IN LOSS OF POINTS.

TABLE A2: FINANCIAL REFERENCES

	TARGETED GOALS	TENDERED GOAL	POINTS CLAIMED BY TENDERER	ALLOCATED POINTS
1	Tenderer submitted banking details proof attached	5		
2	Bank rating of "C" or better	5		
3	Letter of intent from a registered financial institution as a guarantor in the amount of 10% as specified for surety purposes shall be submitted.	10		
	MAXIMUM POINTS	20		

N.B: TENDERERS TO SUBMIT PROOF. NON SUBMISSION WILL RESULT IN LOSS OF POINTS.

F3.13.1

TABLE A3: KEY PERSONEL EXPERIENCE & SPECIFIC KNOWLEDGE

	TARGETED GOALS	TENDERED GOAL	POINTS Claimed by tenderer	ALLOCATED POINTS
1	Site agent 5 years labour intensive construction experience	10		
2	Site agent 5 years in water projects and related works	10		
3	Site agent trained in labour intensive construction methods at least NQF 2	5		
4	Site agent has NQF Level 5 Unit Standard "Develop & Promote Labour Intensive Construction Strategies".	20		
SUB-TOTAL: Experience		40		

N.B: TENDERERS TO SUBMIT CURRICULUM VITAE & CERTIFICATES OF SITE AGENT AND COMPANY PROFILE. NON-SUBMISSION WILL RESULT IN LOSS OF POINTS.

TABLE A4: PLANT AND EQUIPMENT

	TARGETED GOALS	TENDERED GOAL	POINTS Claimed by tenderer	ALLOCATED POINTS
1	1 TLB	5		
2	1 20 ton Excavator	5		
3	2 Tipper trucks	5		
4	1 Water truck (10000lt)	5		
MAXIMUM POINTS		20		

N.B: TENDERERS TO SUBMIT VEHICLE/EQUIPMENT OWNERSHIP PROOF OR INTENTION TO HIRE WITH PROOF OF THE OWNER'S DOCUMENTS. NON-SUBMISSION WILL RESULT IN LOSS OF POINTS. THE MINIMUM SCORE FOR FUNCTIONALITY IS 70

Step 3

Price and BBBEE Contribution. Reduce each responsive Bid offer to a comparative offer and evaluate it using the Bid evaluation method that is indicated in the Bid Data and described below:

Method 2: Financial offer, and preferences	1) Score Bid evaluation points for financial offer.
	2) Confirm that Bidders are eligible for the preferences claimed, and if so, score Bid evaluation points for preferencing.
	3) Calculate total Bid evaluation points.
	4) Rank Bid offers from the highest number of Bid evaluation points to the lowest.
	5) Recommend Bidders with the highest number of Bid evaluation points for the award of the contract, unless there are compelling and justifiable reasons not to do so.

Score financial offers, preferences and quality, as relevant, to two decimal places

F3.13.1

If supply Chain Management bid adjudication committee, or the municipality manager, has resolve that a bid be accepted, the successful and unsuccessful bidders shall be notified in writing of this decision.

	<p>Section 62 of the local municipality services Act 2000(Act 32 of 2000) gives any person whose rights have been affected by such a decision, the rights to appeal such decision within 21 days of the notification of the decision. Any bidder wishing to exercise this right must submit their appeal to the Municipal manager, P.O Box 4100,Polokwane,0700</p> <ul style="list-style-type: none"> • set out the reasons for the appeal • state in which way the appellant's rights have been affected by the decision of the supply • Chain Management Bid Adjudication Committee or Municipal manager as applicable <p>Bidders are also hereby informed of their right to request reasons for the decision in terms of the Promotion of Administrative Justice Act(No 3 of 2000)</p> <p>The notification of decision sent to the bidder is not acceptance in terms of the form of offer and acceptance and no rights shall accrue to the successful bidder in terms of this notification.</p> <p>The consideration of appeals and if necessary, the invalidation of any decision made, shall be dealt with in terms of the Municipality's appeals process.</p>
F.3.18	The number of paper copies of the signed contract to be provided by the employer is one.
F.3.19	The tenderer must attach original or certified copies of BBEE certificate. In the event where tenderers entered into a JV agreement, they must submit original or certified (JV) combined BBEEE certificate
F.3.20	The tenderer must attach the proof of updated municipal rates and taxes. If the tenderer reside in a non-rateable municipal area, they must attach an affidavit for the company and its directors.

Annex: Standard Conditions of Tender

F.1 General

F.1.1 Actions

F.1.1.1 The employer and each tenderer submitting a tender offer shall comply with these conditions of tender. In their dealings with each other, they shall discharge their duties and obligations as set out in F.2 and F.3, timeously and with integrity, and behave equitably, honestly and transparently, comply with all legal obligations and not engage in anticompetitive practices.

F.1.1.2 The employer and the tenderer and all their agents and employees involved in the tender process shall avoid conflicts of interest and where a conflict of interest is perceived or known, declare any such conflict of interest, indicating the nature of such conflict. Tenderers shall declare any potential conflict of interest in their tender submissions. Employees, agents and advisors of the employer shall declare any conflict of interest to whoever is responsible for overseeing the procurement process at the start of any deliberations relating to the procurement process or as soon as they become aware of such conflict, and abstain from any decisions where such conflict exists or recuse themselves from the procurement process, as appropriate. Note: 1) A conflict of interest may arise due to a conflict of roles which might provide an incentive for improper acts in some circumstances. A conflict of interest can create an appearance of impropriety that can undermine confidence in the ability of that person to act properly in his or her position even if no improper acts result. 2) Conflicts of interest in respect of those engaged in the procurement process include direct, indirect or family interests in the tender or outcome of the procurement process and any personal bias, inclination, obligation, allegiance or loyalty which would in any way affect any decisions taken.

F.1.1.3 The employer shall not seek and a tenderer shall not submit a tender without having a firm intention and the capacity to proceed with the contract.

F.1.2 Tender Documents

The documents issued by the employer for the purpose of a tender offer are listed in the tender data.

F.1.3 Interpretation

F.1.3.1 The tender data and additional requirements contained in the tender schedules that are included in the returnable documents are deemed to be part of these conditions of tender.

F.1.3.2 These conditions of tender, the tender data and tender schedules which are only required for tender evaluation purposes, shall not form part of any contract arising from the invitation to tender.

F.1.3.3 For the purposes of these conditions of tender, the following definitions apply:

a) **Conflict of interest** means any situation in which:

- i) Someone in a position of trust has competing professional or personal interests which make it difficult to fulfil his or her duties impartially;
- ii) An individual or organisation is in a position to exploit a professional or official capacity in some way for their personal or corporate benefit; or
- iii) Incompatibility or contradictory interests exist between an employee and the organisation which employs that employee.

b) **Comparative offer** means the tenderer's financial offer after all tendered parameters that will affect the value of the financial offer have been taken into consideration in order to enable comparisons to be made between offers on a comparative basis.

c) **corrupt practice** means the offering, giving, receiving or soliciting of anything of value to influence the action of the employer or his staff or agents in the tender process; and

d) **Fraudulent practice** means the misrepresentation of the facts in order to influence the tender process or the award of a contract arising from a tender offer to the detriment of the employer, including collusive practices intended to establish prices at artificial levels

e) **Organization** means a company, firm, enterprise, association or other legal entity, whether incorporated or not, or a public body

f) **Quality (functionality)** means the totality of features and characteristics of a product or service that bear on its ability to satisfy stated or implied needs

F.1.4 Communication and employer's agent

Each communication between the employer and a tenderer shall be to or from the employer's agent only, and in a form that can be readily read, copied and recorded. Communications shall be in the English language. The employer shall not take any responsibility for non-receipt of communications from or by a tenderer. The name and contact details of the employer's agent are stated in the tender data.

F.1.5 The employer's right to accept or reject any tender offer

F.1.5.1 The employer may accept or reject any variation, deviation, tender offer, or alternative tender offer, and may cancel the tender process and reject all tender offers at any time before the formation of a contract. The employer shall not accept or incur any liability to a tenderer for such cancellation and rejection, but will give written reasons for such action upon written request to do so.

F.1.5.2 The employer may not subsequent to the cancellation or abandonment of a tender process or the rejection of all responsive tender offers re-issue a tender covering substantially the same scope of work within a period of six months unless only one tender was received and such tender was returned unopened to the tenderer.

F.1.6 Procurement procedures

F.1.6.1 General

Unless otherwise stated in the tender data, a contract will, subject to F.3.13, be concluded with the tenderer who in terms of F.3.11 is the highest ranked or the tenderer scoring the highest number of tender evaluation points as relevant, based on the tender submissions that are received at the closing time for tenders.

F.1.6.2 Competitive negotiation procedure

F.1.6.2.1 Where the tender data require that the competitive negotiation procedure is to be followed, tenderers shall submit tender offers in response to the proposed contract in the first round of submissions. Notwithstanding the requirements of F.3.4, the employer shall announce only the names of the tenderers who make a submission. The requirements of F.3.8 relating to the material deviations or qualifications which affect the competitive position of tenderers shall not apply.

F.1.6.2.2 All responsive tenderers, or not less than three responsive tenderers that are highest ranked in terms of the evaluation method and evaluation criteria stated in the tender data, shall be invited in each round to entering to competitive negotiations, based on the principle of equal treatment and keeping confidential the proposed solutions and associated information. Notwithstanding the provisions of F.2.17, the employer may request that tenders be clarified, specified and fine-tuned in order to improve a tenderer's competitive position provided that such clarification, specification, fine-tuning or additional information does not alter any fundamental aspects of the offers or impose substantial new requirements which restrict or distort competition or have a discriminatory effect.

F.1.6.2.3 At the conclusion of each round of negotiations, tenderers shall be invited by the employer to make afresh tender offer, based on the same evaluation criteria, with or without adjusted weightings. Tenderers shall be advised when they are to submit their best and final offer.

F.1.6.2.4 The contract shall be awarded in accordance with the provisions of F.3.11 and F.3.13 after tenderers have been requested to submit their best and final offer.

F.1.6.3 Proposal procedure using the two stage-system

F.1.6.3.1 Option 1

Tenderers shall in the first stage submit technical proposals and, if required, cost parameters around which a contract may be negotiated. The employer shall evaluate each responsive submission in terms of the method of evaluation stated in the tender data, and in the second stage negotiate a contract with the tenderer scoring the highest number of evaluation points and award the contract in terms of these conditions of tender.

F.1.6.3.2 Option 2

F.1.6.3.2.1 Tenderers shall submit in the first stage only technical proposals. The employer shall invite all responsive tenderers to submit tender offers in the second stage, following the issuing of procurement documents.

F.1.6.3.2.2 The employer shall evaluate tenders received during the second stage in terms of the method of evaluation stated in the tender data, and award the contract in terms of these conditions of tender.

F.2 Tenderer's obligations

F.2.1 Eligibility

F.2.1.1 Submit a tender offer only if the tenderer satisfies the criteria stated in the tender data and the tenderer, or any of his principals, is not under any restriction to do business with employer.

F.2.1.2 Notify the employer of any proposed material change in the capabilities or formation of the tendering entity (or both) or any other criteria which formed part of the qualifying requirements used by the employer as the basis in a prior process to invite the tenderer to submit a tender offer and obtain the employer's written approval to do so prior to the closing time for tenders.

F.2.2 Cost of tendering

Accept that, unless otherwise stated in the tender data, the employer will not compensate the tenderer for any costs incurred in the preparation and submission of a tender offer, including the costs of any testing necessary to demonstrate that aspects of the offer complies with requirements.

F.2.3 Check documents

Check the tender documents on receipt for completeness and notify the employer of any discrepancy or omission.

F.2.4 Confidentiality and copyright of documents

Treat as confidential all matters arising in connection with the tender. Use and copy the documents issued by the employer only for the purpose of preparing and submitting a tender offer in response to the invitation.

F.2.5 Reference documents

Obtain, as necessary for submitting a tender offer, copies of the latest versions of standards, specifications, conditions of contract and other publications, which are not attached but which are incorporated into the tender documents by reference.

F.2.6 Acknowledge addenda

Acknowledge receipt of addenda to the tender documents, which the employer may issue, and if necessary apply for an extension to the closing time stated in the tender data, in order to take the addenda into account.

F.2.7 Clarification meeting

Attend, where required, a clarification meeting at which tenderers may familiarize themselves with aspects of the proposed work, services or supply and raise questions. Details of the meeting(s) are stated in the tender data.

F.2.8 Seek clarification

Request clarification of the tender documents, if necessary, by notifying the employer at least five working days before the closing time stated in the tender data.

F.2.9 Insurance

Be aware that the extent of insurance to be provided by the employer (if any) might not be for the full cover required in terms of the conditions of contract identified in the contract data. The tenderer is advised to seek qualified advice regarding insurance.

F.2.10 pricing the tender offer

F.2.10.1 Include in the rates, prices, and the tendered total of the prices (if any) all duties, taxes (except Value-added Tax (VAT), and other levies payable by the successful tenderer, such duties, taxes and levies being those applicable 14 days before the closing time stated in the tender data.

F.2.10.2 Show VAT payable by the employer separately as an addition to the tendered total of the prices.

F.2.10.3 Provide rates and prices that are fixed for the duration of the contract and not subject to adjustment except as provided for in the conditions of contract identified in the contract data.

F.2.10.4 State the rates and prices in Rand unless instructed otherwise in the tender data. The conditions of contract identified in the contract data may provide for part payment in other currencies.

F.2.11 Alterations to documents

Do not make any alterations or additions to the tender documents, except to comply with instructions issued by the employer, or necessary to correct errors made by the tenderer. All signatories to the tender offer shall initial all such alterations. Erasures and the use of masking fluid are prohibited.

F.2.12 Alternative tender offers

F.2.12.1 Unless otherwise stated in the tender data, submit alternative tender offers only if a main tender offer, strictly in accordance with all the requirements of the tender documents, is also submitted as well as a schedule that compares the requirements of the tender documents with the alternative requirements that are proposed.

F.2.12.2 Accept that an alternative tender offer may be based only on the criteria stated in the tender data or criteria otherwise acceptable to the employer.

F.2.13 submitting a tender offer

F.2.13.1 Submit one tender offer only, either as a single tendering entity or as a member in a joint venture to provide the whole of the works, services or supply identified in the contract data and described in the scope of works, unless stated otherwise in the tender data.

F.2.13.2 Return all returnable documents to the employer after completing them in their entirety, either electronically (if they were issued in electronic format) or by writing legibly in non-erasable ink.

F.2.13.3 Submit the parts of the tender offer communicated on paper as an original plus the number of copies stated in the tender data, with an English translation of any documentation in a language other than English, and the parts communicated electronically in the same format as they were issued by the employer.

F.2.13.4 Sign the original and all copies of the tender offer where required in terms of the tender data. The employer will hold all authorized signatories liable on behalf of the tenderer. Signatories for tenderers proposing to contract as joint ventures shall state, which of the signatories is the lead partner whom the employer shall hold liable for the purpose of the tender offer

F.2.13.5 Seal the original and each copy of the tender offer as separate packages marking the packages as "ORIGINAL" and "COPY". Each package shall state on the outside the employer's address and identification details stated in the tender data, as well as the tenderer's name and contact address.

F.2.13.6 Where a two-envelope system is required in terms of the tender data, place and seal the returnable documents listed in the tender data in an envelope marked "financial proposal" and place the remaining returnable documents in an envelope marked "technical proposal". Each envelope shall state on the outside the employer's address and identification details stated in the tender data, as well as the tenderer's name and contact address.

F.2.13.7 Seal the original tender offer and copy packages together in an outer package that states on the outside only the employer's address and identification details as stated in the tender data.

F.2.13.8 Accept that the employer will not assume any responsibility for the misplacement or premature opening of the tender offer if the outer package is not sealed and marked as stated.

F.2.13.9 Accept that tender offers submitted by facsimile or e-mail will be rejected by the employer, unless stated otherwise in the tender data.

F.2.14 Information and data to be completed in all respects

Accept that tender offers, which do not provide all the data or information requested completely and in the required, may be regarded by the employer as non-responsive.

F.2.15 Closing time

F.2.15.1 Ensure that the employer receives the tender offer at the address specified in the tender data not later than the closing time stated in the tender data. Accept that proof of posting shall not be accepted as proof of delivery.

F.2.15.2 Accept that, if the employer extends the closing time stated in the tender data for any reason, the requirements of these conditions of tender apply equally to the extended deadline.

F.2.16 Tender offer validity

F.2.16.1 Hold the tender offer(s) valid for acceptance by the employer at any time during the validity period stated in the tender data after the closing time stated in the tender data.

F.2.16.2 If requested by the employer, consider extending the validity period stated in the tender data for an agreed additional period with or without any conditions attached to such extension.

F.2.16.3 Accept that a tender submission that has been submitted to the employer may only be withdrawn or substituted by giving the employer's agent written notice before the closing time for tenders that a tender is to be withdrawn or substituted.

F.2.16.4 Where a tender submission is to be substituted, submit a substitute tender in accordance with the requirements of F.2.13 with the packages clearly marked as "SUBSTITUTE".

F.2.17 Clarification of tender offer after submission

Provide clarification of a tender offer in response to a request to do so from the employer during the evaluation of tender offers. This may include providing a breakdown of rates or prices and correction of arithmetical errors by the adjustment of certain rates or item prices (or both). No change in the competitive position of tenderers or substance of the tender offer is sought, offered, or permitted.

Note: Sub-clause F.2.17 does not preclude the negotiation of the final terms of the contract with a preferred tenderer following a competitive selection process, should the Employer elect to do so.

F.2.18 Provide other material

F.2.18.1 Provide, on request by the employer, any other material that has a bearing on the tender offer, the tenderer's commercial position (including notarized joint venture agreements), referencing arrangements, or samples of materials, considered necessary by the employer for the purpose of a full and fair risk assessment. Should the tenderer not provide the material, or a satisfactory reason as to why it cannot be provided, by the time for submission stated in the employer's request, the employer may regard the tender offer as non-responsive.

F.2.18.2 Dispose of samples of materials provided for evaluation by the employer, where required.

F.2.19 Inspections, tests and analysis

Provide access during working hours to premises for inspections, tests and analysis as provided for in the tender data.

F.2.20 Submit securities, bonds, policies, etc

If requested, submit for the employer's acceptance before formation of the contract, all securities, bonds, guarantees, policies and certificates of insurance required in terms of the conditions of contract identified in the contract data.

F.2.21 Check final draft

Check the final draft of the contract provided by the employer within the time available for the employer to issue the contract.

F.2.22 Return of other tender documents

If so instructed by the employer, return all retained tender documents within 28 days after the expiry of the validity period stated in the tender data.

F.2.23 Certificates

Include in the tender submission or provide the employer with any certificates as stated in the tender data.

F.3 The employer's undertakings

F.3.1 Respond to requests from the tenderer

F.3.1.1 Unless otherwise stated in the tender Data respond to a request for clarification received up to five working days before the tender closing time stated in the Tender Data and notify all tenderers who drew procurement documents.

F.3.1.2 Consider any request to make a material change in the capabilities or formation of the tendering entity (or both) or any other criteria which formed part of the qualifying requirements used to prequalify a

tenderer to submit a tender offer in terms of a previous procurement process and deny any such request if as a consequence:

- a) An individual firm, or a joint venture as a whole, or any individual member of the joint venture fails to meet any of the collective or individual qualifying requirements;
- b) The new partners to a joint venture were not prequalified in the first instance, either as individual firms or as another joint venture; or
- c) In the opinion of the Employer, acceptance of the material change would compromise the outcome of the prequalification process.

F.3.2 Issue Addenda

If necessary, issue addenda that may amend or amplify the tender documents to each tenderer during the period from the date that tender documents are available until three days before the tender closing time stated in the Tender Data. If, as a result a tenderer applies for an extension to the closing time stated in the Tender Data, the Employer may grant such extension and, shall then notify all tenderers who drew documents.

F.3.3 Return late tender offers

Return tender offers received after the closing time stated in the Tender Data, unopened, (unless it is necessary to open a tender submission to obtain a forwarding address), to the tenderer concerned.

F.3.4 Opening of tender submissions

F.3.4.1 Unless the two-envelope system is to be followed, open valid tender submissions in the presence of tenderers' agents who choose to attend at the time and place stated in the tender data. Tender submissions for which acceptable reasons for withdrawal have been submitted will not be opened.

F.3.4.2 Announce at the meeting held immediately after the opening of tender submissions, at a venue indicated in the tender data, the name of each tenderer whose tender offer is opened and, where applicable, the total of his prices, preferences claimed and time for completion for the main tender offer only.

F.3.4.3 Make available the record outlined in F.3.4.2 to all interested persons upon request.

F.3.5 Two-envelope system

F.3.5.1 Where stated in the tender data that a two-envelope system is to be followed, open only the technical proposal of valid tenders in the presence of tenderers' agents who choose to attend at the time and place stated in the tender data and announce the name of each tenderer whose technical proposal is opened.

F.3.5.2 Evaluate the quality of the technical proposals offered by tenderers, then advise tenderers who remain in contention for the award of the contract of the time and place when the financial proposals will be opened. Open only the financial proposals of tenderers, who score in the quality evaluation more than the minimum number of points for quality stated in the tender data, and announce the score obtained for the technical proposals and the total price and any preferences claimed. Return unopened financial proposals to tenderers whose technical proposals failed to achieve the minimum number of points for quality.

F.3.6 Non-disclosure

Not disclose to tenderers, or to any other person not officially concerned with such processes, information relating to the evaluation and comparison of tender offers, the final evaluation price and recommendations for the award of a contract, until after the award of the contract to the successful tenderer.

F.3.7 Grounds for rejection and disqualification

Determine whether there has been any effort by a tenderer to influence the processing of tender offers and instantly disqualify a tenderer (and his tender offer) if it is established that he engaged in corrupt or fraudulent practices.

F.3.8 Test for responsiveness

F.3.8.1 Determine, after opening and before detailed evaluation, whether each tender offer properly received:

- a) complies with the requirements of these Conditions of Tender,
- b) Has been properly and fully completed and signed, and
- c) is responsive to the other requirements of the tender documents.

F.3.8.2 A responsive tender is one that conforms to all the terms, conditions, and specifications of the tender documents without material deviation or qualification. A material deviation or qualification is one which, in the Employer's opinion, would:

- a) Detrimentally affect the scope, quality, or performance of the works, services or supply identified in the Scope of Work,
 - b) Significantly change the Employer's or the tenderer's risks and responsibilities under the contract, or
 - c) Affect the competitive position of other tenderers presenting responsive tenders, if it were to be rectified.
- Reject a non-responsive tender offer, and not allow it to be subsequently made responsive by correction or withdrawal of the non-conforming deviation or reservation.

F.3.9 Arithmetical errors, omissions and discrepancies

F.3.9.1 Check responsive tenders for discrepancies between amounts in words and amounts in figures. Where there is a discrepancy between the amounts in figures and the amount in words, the amount in words shall govern.

F.3.9.2 Check the highest ranked tender or tenderer with the highest number of tender evaluation points after the evaluation of tender offers in accordance with F.3.11 for:

- a) The gross misplacement of the decimal point in any unit rate;
- b) Omissions made in completing the pricing schedule or bills of quantities; or
- c) Arithmetic errors in:
 - i) Line item totals resulting from the product of a unit rate and a quantity in bills of quantities or schedules of prices; or
 - ii) The summation of the prices.

F.3.9.3 Notify the tenderer of all errors or omissions that are identified in the tender offer and either confirm the tender offer as tendered or accept the corrected total of prices.

F.3.9.4 Where the tenderer elects to confirm the tender offer as tendered, correct the errors as follows:

- a) If bills of quantities or pricing schedules apply and there is an error in the line item total resulting from the product of the unit rate and the quantity, the line item total shall govern and the rate shall be corrected. Where there is an obviously gross misplacement of the decimal point in the unit rate, the line item total as quoted shall govern, and the unit rate shall be corrected.
- b) Where there is an error in the total of the prices either as a result of other corrections required by this checking process or in the tenderer's addition of prices, the total of the prices shall govern and the tenderer will be asked to revise selected item prices (and their rates if bills of quantities apply) to achieve the tendered total of the prices.

F.3.10 Clarification of a tender offer

Obtain clarification from a tenderer on any matter that could give rise to ambiguity in a contract arising from the tender offer.

F.3.11 Evaluation of tender offers

F.3.11.1 General

Appoint an evaluation panel of not less than three persons. Reduce each responsive tender offer to a comparative offer and evaluate them using the tender evaluation methods and associated evaluation criteria and weightings that are specified in the tender data.

F.3.11.2 Method 1: Financial offer

In the case of a financial offer:

- a) Rank tender offers from the most favourable to the least favourable comparative offer.
- b) Recommend the highest ranked tenderer for the award of the contract, unless there are compelling and justifiable reasons not to do so.
- c) Re-rank all tenderers should there be compelling and justifiable reasons not to recommend the highest ranked tenderer and recommend the highest ranked tenderer, unless there are compelling and justifiable reasons not to do so and the process set out in this sub clause is repeated.

F.3.11.3 Methods 2: Financial offer and preference

In the case of a financial offer and preferences:

- a) Score each tender in respect of the financial offer made and preferences claimed, if any, in accordance with the provisions of F.3.11.7 and F.3.11.8.

- b) Calculate the total number of tender evaluation points (TEV) in accordance with the following formula:

$$TEV = NFO + NP$$

Where: NFO is the number of tender evaluation points awarded for the financial offer made in accordance with F.3.11.7;

- NP is the number of tender evaluation points awarded for preferences claimed in accordance with F.3.11.8.
- c) Rank tender offers from the highest number of tender evaluation points to the lowest.
 - d) Recommend the tenderer with the highest number of tender evaluation points for the award of the contract, unless there are compelling and justifiable reasons not to do so.
 - e) Rescore and re-rank all tenderers should there be compelling and justifiable reasons not to recommend the tenderer with the highest number of tender evaluation points, and recommend the tenderer with the highest number of tender evaluation points, unless there are compelling and justifiable reasons not to do so and the process set out in this sub clause is repeated

F.3.11.4 Method 3: Financial offer and quality

In the case of a financial offer and quality:

- a) Score each tender in respect of the financial offer made and the quality offered in accordance with the provisions of F.3.11.7 and F.3.11.9, rejecting all tender offers that fail to score the minimum number of points for quality stated in the tender data, if any.

- b) Calculate the total number of tender evaluation points (TEV) in accordance with the following formula:
TEV = NFO + NQ

Where: NFO is the number of tender evaluation points awarded for the financial offer made in accordance with F.3.11.7;

NQ is the number of tender evaluation points awarded for quality offered in accordance with F.3.11.9.

- c) Rank tender offers from the highest number of tender evaluation points to the lowest.
- d) Recommend tenderer with the highest number of tender evaluation points for the award of the contract, unless there are compelling and justifiable reasons not to do so.
- e) Rescore and re-rank all tenderers should there be compelling and justifiable reasons not to recommend the tenderer with the highest number of tender evaluation points and recommend the tenderer with the highest number of tender evaluation points, unless there are compelling and justifiable reasons not to do so and the process set out in this sub clause is repeated.

F.3.11.5 Method 4: Financial offer, quality and preferences

In the case of a financial offer, quality and preferences:

- a) Score each tender in respect of the financial offer made, preference claimed, if any, and the quality offered in accordance with the provisions of F.3.11.7 to F.3.11.9, rejecting all tender offers that fail to score the minimum number of points for quality stated in the tender data, if any.

- b) Calculate the total number of tender evaluation points (TEV) in accordance with the following formula, unless otherwise stated in the Tender Data:

TEV = NFO + NP + NQ

Where: NFO is the number of tender evaluation points awarded for the financial offer made in accordance with F.3.11.7;

NP is the number of tender evaluation points awarded for preferences claimed in accordance with F.3.11.8.

NQ is the number of tender evaluation points awarded for quality offered in accordance with F.3.11.9.

- c) Rank tender offers from the highest number of tender evaluation points to the lowest.
- d) Recommend the tenderer with the highest number of tender evaluation points for the award of the contract, unless there are compelling and justifiable reasons not to do so.
- e) Rescore and re-rank all tenderers should there be compelling and justifiable reasons not to recommend the tenderer with the highest number of tender evaluation points and recommend the tenderer with the highest number of tender evaluation points, unless there are compelling and justifiable reasons not to do so and the process set out in this sub clause is repeated.

F.3.11.6 Decimal places

Score price, preference and functionality, as relevant, to two decimal places.

F.3.11.7 Scoring Price

Score price of remaining responsive Bid offers using the following formula:

$N_{FO} = W_1 \times A$ Where:

N_{FO} = the number of Bid evaluation points awarded for price.

W_1 = the maximum possible number of Bid evaluation points awarded for price as stated in the Bid Data.

A = a number calculated using the formula and option described in Table F.1 as stated in the tender data.

Table F.1: formulae for calculating the value of A

Formula	Basis for comparison	Option 1	Option 2
---------	----------------------	----------	----------

1	Highest price or discount	$A = (1 + \frac{(P - P_m)}{P_m})$	$A = P/P_m$
2	Lowest price or percentage commission/fee	$A = (1 - \frac{(P - P_m)}{P_m})$	$A = P_m/P$
<p>P_m is the comparative offer of the most favourable comparative offer. P is the comparative offer of the Bid offer under consideration.</p>			

F.3.11.8 Scoring Preferences

Confirm that tenderers are eligible for the preferences claimed in accordance with provisions of the tender data and reject all claims for preferences where tenderers are not eligible for such preferences.

Calculate the total number of tender evaluation points for preferences claimed in accordance with provisions of the tender data.

F.3.11.9 Scoring Preferences

Score each of the criteria and sub criteria for quality in accordance with the provisions of the tender data. Calculate the total number of tender evaluation points for quality using the following formula:

$$N_{QO} = W_2 \times S_0 / M_S$$

Where

S₀ is the score for quality allocated to the submission under consideration

M_S is the maximum possible score for quality in respect of a submission; and

W₂ is the maximum possible number of tender evaluation points awarded for the quality as stated in the tender data.

F.3.12 Insurance provided by the employer

If requested by the proposed successful Bidder, submit for the Bidder's information the policies and / or certificates of insurance which the conditions of contract identified in the contract data, require the employer to provide.

F.3.13 Acceptance of Bid offer

F.3.13.1 Accept Bid offer only if the Bidder satisfies the legal requirements stated in the Bid Data.

F.3.13.2 Notify the successful Bidder of the employer's acceptance of his Bid offer by completing and returning one copy of the form of offer and acceptance before the expiry of the validity period stated in the Bid data, or agreed additional period. Providing the form of offer and acceptance does not contain any qualifying statements, it will constitute the formation of a contract between the employer and the successful Bidder as described in the form of offer and acceptance.

F.3.14 Notice to unsuccessful Bidders

Successful bidders will be on the website.

F.3.15. Prepare contract documents

If necessary, revise documents that shall form part of the contract and that were issued by the employer as part of the Bid documents to take account of:

- a) Addenda issued during the Bid period,
- b) Inclusion of some of the returnable documents,
- c) Other revisions agreed between the employer and the successful Bidder, and
- d) The schedule of deviations attached to the form of offer and acceptance, if any.

F.3.16 Issue final contract

Prepare and issue the final draft of contract documents to the successful Bidder for acceptance as soon as possible after the date of the employer's signing of the form of offer and acceptance (including the schedule of deviations, if any). Only those documents that the conditions of Bid require the Bidder to submit, after acceptance by the employer, shall be included.

F.3.17 Complete adjudicator's contract

Unless alternative arrangements have been agreed or otherwise provided for in the contract, arrange for both parties to complete formalities for appointing the selected adjudicator at the same time as the main contract is signed.

F.3.18 Provide copies of the contracts

Provide to the successful Bidder the number of copies stated in the Bid Data of the signed copy of the contract as soon as possible after completion and signing of the form of offer and acceptance.



CAPRICORN DISTRICT MUNICIPALITY

T2.1 List of Returnable Documents

The Bidder must complete the following returnable documents:

1 Returnable Schedules required for Bid evaluation purposes

- MBD 2: Tax Clearance Certificate requirements
- BBBEE Certificate
- Bank Rating
- Certified copy of company registration documents (CK Documents)
- Certified copies of directors ID
- Letter of good standing (C.O.I.D.A)
- Attended Compulsory Site meeting
- Authority of Signatory (own company letterhead)
- Signing of Form of Offer
- BOQ filled in using a black pen
- Alterations signed
- CIDB grading 6CEPE/7CE - Contract A)
- List of Returnable documents as listed on T2.1
- Municipal rates and taxes not older than 3 months for both residence and business
- Joint Venture agreement(in case of JV)
- Proof of ownership of plant and machinery
- Certified copies of qualifications not older than 3 months
- Addendum

2 Other documents required only for Bid evaluation purposes

- Certificate of Contractor Registration issued by the Construction Industry Development Board (6CEPE/7CE)

3 Returnable Schedules that will be required for bid evaluation purpose

- MBD 1: Invitation to Bid
- MBD 3.1: Pricing Schedule – Firm Prices
- MBD 3.2: Pricing Schedule – Non-Firm prices
- MBD 4: Declaration of interest
- MBD 5: Declaration for Procurement above R10 Million (All applicable taxes included)
- MBD 6.1: Preference Points Claim Form In Terms Of The Preferential Procurement Regulations 2017
- MBD 7.2: Contract Form – Rendering of services
- MBD 8: Declaration of Bidder's Past Supply Chain Management Practices
- MBD 9: Certificate of Independent Bid Determination

N.B: FAILURE TO COMPLETE OR SIGN ALL THE DOCUMENTS LISTED ABOVE WILL RESULT IN YOUR TENDER NOT BEING CONSIDERED

4 Other documents that will be incorporated into the contract

5 Form of Offer

6 C1.2 Contract Data (Part 2)

7 C6.2 Bills of quantities

Record of Addenda to Bid documents

We confirm that the following communications received from the Employer before the submission of this Bid offer, amending the Bid documents, have been taken into account in this Bid offer:

	Date	Title or Details
1.		
2.		
3.		
4.		
5.		
6.		
7.		

Attach additional pages if more space is required.

Signed		Date	
Name		Position	
Bidder			

**EXAMPLE FOR USE BY THE TENDERER WHEN COMPILING THE AUTHORITY
CERTIFICATE**

**Certificate of Authority for Power of Attorney
(TO BE PRINTED ON COMPANY'S LETTER HEAD)**

Indicate the status of the tenderer by ticking the appropriate box hereunder. The tenderer must complete the certificate set out below for the relevant category.

A Company	B Partnership	C Joint Venture	D Sole Proprietor	E Close Corporation

A. Certificate for company

I,.....,chairperson of the board of directors of
....., hereby confirm that by resolution of the board (copy attached) taken on
.....20.....,Mr/Mrs.....acting in the capacity
of.....,was authorised to sign all documents in connection with this tender
and any contract resulting from it on behalf of the company.

As witness

1.....
.....
Chairman
2.....
.....
Date

B. Certificate of partnership

We, the undersigned, being the key partners in the business trading as
hereby authorise Mr/Mrs....., acting in the capacity
of.....to sign all documents in connection with the tender for
Contract.....and any contract resulting from it on our behalf.

NAME	ADDRESS	SIGNATURE	DATE

NOTE: This certificate is to be completed and signed by all of the key partners upon whom rests the direction of the affairs of the Partnership as a whole.

C. Certificate for Joint Venture

We, the undersigned, are submitting this tender offer in Joint Venture and hereby authorise Mr/Mrs....., authorised signatory of the company, Acting in the capacity of lead partner, to sign all documents in connection with the tender offer for Contract.....and any other contract resulting from it on our behalf. This authorisation is evidenced by the attached power of attorney signed by legally authorised signatories of all the partners to the Joint Venture.

NAME OF FIRM	ADDRESS	AUTHORISING SIGNATURE, NAME & CAPACITY
Lead partner		

D. Certificate for sole proprietor

I,, hereby confirm that I am the sole owner of the business trading as.....

As Witness:

1..... Signature: Sole owner
 2..... Date

E. Certificate for Close Corporation

We, the undersigned, being the key members in the business trading as.....hereby authorise Mr/Mrs..... Acting in the capacity of....., to sign all documents in connection with the tender for Contract.....and any contract resulting from it on our behalf.

NAME	ADDRESS	SIGNATURE	DATE

NOTE: This certificates are only Examples. Bidding Entities are requested to submit in their own company letter heads.

Schedule of Proposed Subcontractors

	<p>We notify you that it is our intention to employ the following Subcontractors for work in this contract. If we are awarded a contract we agree that this notification does not change the requirement for us to submit the names of proposed Subcontractors in accordance with requirements in the contract for such appointments. If there are no such requirements in the contract, then your written acceptance of this list shall be binding between us.</p>			
	Name and address of proposed Subcontractor	Nature and extent of work	CIDB grading of the sub-contractor	Previous experience with Subcontractor.
1.				
2.				
3.				
4.				
5.				
6.				
Signed		Date		
Name		Position		
Bidder				

Schedule of Plant and Equipment

The following are lists of major items of relevant equipment that I/we presently own or lease and will have available for this contract or will acquire or hire for this contract if my/our Bid is accepted.

(a) Details of major equipment that is owned by and immediately available for this contract.

Quantity	Description, size, capacity, etc.

Attach additional pages if more space is required.

(b) Details of major equipment that will be hired, or acquired for this contract if my/our Bid is acceptable.

Quantity	Description, size, capacity, etc.

Attach additional pages if more space is required.

Signed		Date	
Name		Position	
Bidder			

N.B: Bidders to submit certified proof of ownership from the relevant Authority. If hiring proof of certified ownership documents from the plant hire to be submitted with the tender.

Schedule of the Bidder's Experience

The following is a statement of similar work successfully executed by myself/ourselves:

Employer, contact person and telephone number.	Description of contract	Value of work inclusive of VAT (Rand)	Date completed

Signed		Date	
Name		Position	
Bidder			

N.B: Evaluation will be based on the first four projects only. Certificates of practical completion for completed projects. Appointment letters for projects not completed.

Proposed amendments and qualifications

The Bidder should record any deviations or qualifications he may wish to make to the Bid documents in this Returnable Schedule. Alternatively, a Bidder may state such deviations and qualifications in a covering letter to his Bid and reference such letter in this schedule.

The Bidder's attention is drawn to clause F.3.8 of the Standard Conditions of Bid referenced in the Bid Data regarding the employer's handling of material deviations and qualifications.

Page	Clause or item	Proposal

Signed		Date	
Name		Position	
Bidder			

Schedule of Personnel and Employees

The Tenderer shall state below the number of Personnel and Employees to be employed on the Works.

PERSONNEL AND EMPLOYEES	TENDER			TENDER
	FULL TIME	PART TIME	FULL TIME	PART TIME
1. Technical staff				
2. Clerical staff				
3. Artisans				
4. Semi-skilled				
5. Unskilled labour				
Total				

State the name, qualifications (Certified proof not older than three months) and experience of proposed Site agent:

Date:

SIGNATURE OF TENDERER:

Preliminary Programme

The Tenderer shall detail below or attach a preliminary programme reflecting the proposed order and rate of progress for each portion of the work comprising this Contract. The programme shall be consistent with and in support of his time required for completion and shall be in accordance with the requirements of this tender.

PROGRAMME												
ACTIVITY	WEEKS / MONTHS											

SIGNATURE OF TENDERER:

Signatories Authority (Power Of Attorney)

1. INFORMATION TO BE PROVIDED

1.1 If the Tenderer is a COMPANY

- (a) Affix a certificate copy of the Certificate of Incorporation to this page.
- (b) Affix a copy of the relevant resolution of the Board of Directors, duly signed and dated
- (c) List the Directors

.....
.....

1.2 If the Tenderer is a CLOSE CORPORATION

- (a) Affix a certificate copy of the Founding Statement to this page
- (b) Affix a copy of the relevant resolution of the Members, duly signed and dated
- (c) List the Members

.....
.....

1.3 If the Tenderer is a PARTNERSHIP

- (a) Affix a copy of the relevant resolution on the Partners, duly signed and dated
- (b) List the Partners

.....
.....

1.2 If the Tenderer is a ONE-MAN-CONCERN.

Provided the full name, identity number and qualifications of the person

.....

1.3 If the Tenderer is a JOINT VENTURE

- a) Affix a copy of the original document of information defining the conditions under which the joint venture will function, its period of duration and the participating persons, companies and/or firms
- b) Affix a certificate signed for or on behalf of each participating person, company and/or firm authorizing the person who signed the tender to do so.

1.4 If the Tenderer is a CONCERN OTHER than these listed above

Provide full details of the CONCERN submitting the tender:

.....

Site Inspection Certificate

This is to certify that I,.....

representing and duly authorized by (Tenderer)

.....

attended the site inspection on

.....

Having prior to this site visit carefully examined the tender document, technical information and drawings supplied, I confirm that I was given unrestricted access to inspect those sections of the Site necessary for the execution of the Works.

I further confirm that I am completely satisfied with the scope of work as explained by the Engineer, and am fully aware of all Site conditions and regulations of whatsoever nature that could influence the preparation of our tender.

I therefore append my signature below in agreement that we will not institute any claim against the Employer after submission of our tender based on lack of knowledge of site conditions or regulations appertaining to the execution of this Contract.

Signature of Tenderer's Representative

Date

Signature of Engineer's Representative

Date

NB: THE PERSON WHO ATTENDED THE BRIEFING SESSION TO SIGN ON THIS PAGE, INFORMATION TO BE THE SAME AS THE ONE ON THE ATTENDANCE REGISTER. ANY DEVIATION WILL LEAD TO DISQUALIFICATION.

COMPLIANCE WITH OCCUPATIONAL HEALTH AND SAFETY ACT, 1993 AND CONSTRUCTION REGULATIONS, 2003

The tenderer shall attach to this Form evidence that he is registered and in good standing with a compensation insurer who is approved by Department of Labour in terms of section 80 of the Compensation for Injury and Disease Act (COID)(Act 130 of 1993).

The tenderer is required to disclose, by also attaching documentary evidence to this form, all inspections, investigations and their outcomes conducted by the Department of Labour into the conduct of the tenderer at any time during the 36 months preceding the date of this tender.

SIGNED ON BEHALF OF THE TENDERER:

Note to tenderer:

Discovery that the tenderer has failed to make proper disclosure may result in CDM terminating a contract that flows from this tender on the ground that it has been rendered invalid by the tenderer's misrepresentation.

CONSTRUCTION INDUSTRIES DEVELOPMENT BOARD REGISTRATION

The tenderer is to affix to this page either:

- Written proof of his registration with the CIDB as a Category 7 CE for Contract A (as Minimum)

Or

- Written proof of his application to the CIDB for registration as a contractor in the category listed above.

Note:

1. Failure to provide such documentation as prescribed on this page shall result in this tender not being further considered for the award of the contract.
2. Should this tender be considered for award of the contract, based on proof of submission of application for registration in the appropriate category with the CIDB, and should proof of such subsequent registration not be forthcoming to the employer by the time of award of the contract, then this tender will no longer be considered for the award of the contract.

INVITATION TO BID

YOU ARE HEREBY INVITED TO BID FOR REQUIREMENTS OF THE (CAPRICORN DISTRICT MUNICIPALITY)

BID NUMBER:CLOSING DATE: CLOSING TIME:

DESCRIPTION.....

The successful bidder will be required to fill in and sign a written Contract Form (MBD 7).

BID DOCUMENTS MAY BE POSTED TO:

**CAPRICORN DISTRICT MUNICIPALITY OFFICES
41 BICCARD STREET
POLOKWANE
0700**

OR

DEPOSITED IN THE BID BOX SITUATED AT (*STREET ADDRESS*)

**CAPRICORN DISTRICT MUNICIPALITY OFFICES
41 BICCARD STREET
POLOKWANE
0700**

Bidders should ensure that bids are delivered timeously to the correct address. If the bid is late, it will not be accepted for consideration.

The bid box is generally open 24 hours a day, 7 days a week.

ALL BIDS MUST BE SUBMITTED ON THE OFFICIAL FORMS – (NOT TO BE RE-TYPED)

THIS BID IS SUBJECT TO THE PREFERENTIAL PROCUREMENT POLICY FRAMEWORK ACT AND THE PREFERENTIAL PROCUREMENT REGULATIONS, 2011, THE GENERAL CONDITIONS OF CONTRACT (GCC) AND, IF APPLICABLE, ANY OTHER SPECIAL CONDITIONS OF CONTRACT

NB: NO BIDS WILL BE CONSIDERED FROM PERSONS IN THE SERVICE OF THE STATE (as defined in Regulation 1 of the Local Government: Municipal Supply Chain Management Regulations)

**THE FOLLOWING PARTICULARS MUST BE FURNISHED
(FAILURE TO DO SO MAY RESULT IN YOUR BID BEING DISQUALIFIED)**

NAME OF BIDDER

POSTAL ADDRESS

STREET ADDRESS

TELEPHONE NUMBER CODE.....NUMBER.....

CELLPHONE NUMBER

FACSIMILE NUMBER CODE NUMBER.....

E-MAIL ADDRESS

VAT REGISTRATION NUMBER.....

HAS AN ORIGINAL AND VALID TAX CLEARANCE CERTIFICATE BEEN ATTACHED? (MBD 2) YES/NO

HAS A B-BBEE STATUS LEVEL VERIFICATION CERTIFICATE BEEN SUBMITTED? (MBD 6.1) YES/NO

IF YES, WHO WAS THE CERTIFICATE ISSUED BY?

AN ACCOUNTING OFFICER AS CONTEMPLATED IN THE CLOSE CORPORATION ACT (CCA)

A VERIFICATION AGENCY ACCREDITED BY THE SOUTH AFRICAN NATIONAL ACCREDITATION SYSTEM (SANAS)

A REGISTERED AUDITOR

(Tick applicable box)

(A B-BBEE STATUS LEVEL VERIFICATION CERTIFICATE MUST BE SUBMITTED IN ORDER TO QUALIFY FOR PREFERENCE POINTS FOR B-BBEE)

I. ARE YOU THE ACCREDITED REPRESENTATIVE IN SOUTH AFRICA FOR THE GOODS/SERVICES/WORKS OFFERED?

YES/NO (IF YES ENCLOSE PROOF)

SIGNATURE OF BIDDER

DATE

CAPACITY UNDER WHICH THIS BID IS SIGNED.....

TOTAL BID PRICE..... TOTAL NUMBER OF ITEMS OFFERED.....

ANY ENQUIRIES REGARDING THE BIDDING PROCEDURE MAY BE DIRECTED TO:

Municipality / Municipal Entity:

Department:

Contact Person:

Tel:

Fax:

ANY ENQUIRIES REGARDING TECHNICAL INFORMATION MAY BE DIRECTED TO:

Contact Person:

Tel:

Fax:

TAX CLEARANCE CERTIFICATE REQUIREMENTS

It is a condition of bid that the taxes of the successful bidder must be in order, or that satisfactory arrangements have been made with South African Revenue Service (SARS) to meet the bidder's tax obligations.

1. In order to meet this requirement bidders are required to complete in full the attached form TCC 001 "Application for a Tax Clearance Certificate" and submit it to any SARS branch office nationally. The Tax Clearance Certificate Requirements are also applicable to foreign bidders / individuals who wish to submit bids.
2. SARS will then furnish the bidder with a Tax Clearance Certificate that will be valid for a period of 1 (one) year from the date of approval.
3. The original Tax Clearance Certificate must be submitted together with the bid. Failure to submit the original and valid Tax Clearance Certificate will result in the invalidation of the bid. Certified copies of the Tax Clearance Certificate will not be acceptable.
4. In bids where Consortia / Joint Ventures / Sub-contractors are involved, each party must submit a separate Tax Clearance Certificate.
5. Copies of the TCC 001 "Application for a Tax Clearance Certificate" form are available from any SARS branch office nationally or on the website www.sars.gov.za.
6. Applications for the Tax Clearance Certificates may also be made via eFiling. In order to use this provision, taxpayers will need to register with SARS as eFilers through the website www.sars.gov.za.
7. The electronic verification tax clearance must be accompanied by the verification code.

Application for a Tax Clearance Certificate

Purpose

Select the application option: Tender Good standing

If "Good standing", please state the purpose of this application:

Particulars of applicant

Name/ Legal name (Initials & Surname or registered name)											
Trading name (if applicable)											
ID/Passport no						Company/Close Corp. registered no					
Income Tax ref no						PAYE ref no	7				
VAT registration no	4					SDL ref no	L				
Customs code						UBI ref no	U				
Telephone no						Fax no					
E-mail address											
Physical address											
Postal address											

Particulars of representative (Public Officer/Trustee/Partner)

Surname											
First names											
ID/Passport no						Income Tax ref no					
Telephone no						Fax no					
E-mail address											
Physical address											

Particulars of tender (if applicable)

Tender number:

Estimated tender amount: R

Expected duration of the tender: year(x)

Particulars of the 3 largest contracts previously awarded

Date started	Date finished	Principal	Contact person	Telephone number	Amount

Audit

Are you currently aware of any Audit investigation against you/the company? YES NO

If "YES" provide details:

Appointment of representative/agent (Power of Attorney)

I the undersigned confirm that I require a Tax Clearance Certificate in respect of Tenders or Goodstanding.

I hereby authorize and instruct: to apply to and receive from SARS the applicable Tax Clearance Certificate on my/our behalf.

Signature of representative/agent: Date:

Name of representative/agent:

Declaration

I declare that the information furnished in this application as well as any supporting documents is true and correct in every respect.

Signature of applicant/Public Officer: Date:

Name of applicant/Public Officer:

Notes:

- It is a serious offence to make a false declaration.
- Section 75 of the Income Tax Act, 1962, states: Any person who
 - fails or neglects to furnish, file or submit any return or document as and when required by or under this Act; or
 - without just cause shown by him, refuses or neglects to:
 - furnish, produce or make available any information, documents or things;
 - reply to or answer truly and fully, any questions put to him ...As and when required in terms of this Act ... shall be guilty of an offence ...
- SARS will, under no circumstances, issue a Tax Clearance Certificate unless this form is completed in full.
- Your Tax Clearance Certificate will only be issued on presentation of your South African Identity Document or Passport (Foreigners only) as applicable.

**PRICING SCHEDULE – FIRM PRICES
(PURCHASES)**

NOTE: ONLY FIRM PRICES WILL BE ACCEPTED. NON-FIRM PRICES (INCLUDING PRICES SUBJECT TO RATES OF EXCHANGE VARIATIONS) WILL NOT BE CONSIDERED

IN CASES WHERE DIFFERENT DELIVERY POINTS INFLUENCE THE PRICING, A SEPARATE PRICING SCHEDULE MUST BE SUBMITTED FOR EACH DELIVERY POINT

Name of Bidder.....	Bid Number.....
Closing Time	Closing Date

OFFER TO BE VALID FOR.....DAYS FROM THE CLOSING DATE OF BID.

ITEM NO.	QUANTITY	DESCRIPTION	BID PRICE IN RSA CURRENCY **(ALL APPLICABLE TAXES INCLUDED)
-	Required by:	
-	At:	
-	Brand and Model	
-	Country of Origin	
-	Does the offer comply with the specification(s)?		*YES/NO
-	If not to specification, indicate deviation(s)	
-	Period required for delivery	
-	*Delivery:		Firm/Not firm
-	Delivery basis	

Note: All delivery costs must be included in the bid price, for delivery at the prescribed destination.

** "all applicable taxes" includes value- added tax, pay as you earn, income tax, unemployment insurance fund contributions and skills development levies.

*Delete if not applicable

PRICE ADJUSTMENTS

A NON-FIRM PRICES SUBJECT TO ESCALATION

1. IN CASES OF PERIOD CONTRACTS, NON FIRM PRICES WILL BE ADJUSTED (LOADED) WITH THE ASSESSED CONTRACT PRICE ADJUSTMENTS IMPLICIT IN NON FIRM PRICES WHEN CALCULATING THE COMPARATIVE PRICES
2. IN THIS CATEGORY PRICE ESCALATIONS WILL ONLY BE CONSIDERED IN TERMS OF THE FOLLOWING FORMULA:

$$Pa = (1 - V)Pt \left(D1 \frac{R1t}{R1o} + D2 \frac{R2t}{R2o} + D3 \frac{R3t}{R3o} + D4 \frac{R4t}{R4o} \right) + VPt$$

Where:

- Pa = The new escalated price to be calculated.
- (1-V) Pt = 85% of the original bid price. **Note that Pt must always be the original bid price and not an escalated price.**
- D1, D2.. = Each factor of the bid price eg. labour, transport, clothing, footwear, etc. The total of the various factors D1,D2...etc. must add up to 100%.
- R1t, R2t..... = Index figure obtained from new index (depends on the number of factors used).
- R1o, R2o = Index figure at time of bidding.
- VPt = 15% of the original bid price. This portion of the bid price remains firm i.e. it is not subject to any price escalations.

3. The following index/indices must be used to calculate your bid price:

Index..... Dated..... Index..... Dated..... Index..... Dated.....
 Index..... Dated..... Index..... Dated..... Index..... Dated.....

- 4 FURNISH A BREAKDOWN OF YOUR PRICE IN TERMS OF ABOVE-MENTIONED FORMULA. THE TOTAL OF THE VARIOUS FACTORS MUST ADD UP TO 100%.

FACTOR (D1, D2 etc. eg. Labour, transport etc.)	P PERCENTAGE OF BID PRICE

B PRICES SUBJECT TO RATE OF EXCHANGE VARIATIONS

1. Please furnish full particulars of your financial institution, state the currencies used in the conversion of the prices of the items to South African currency, which portion of the price is subject to rate of exchange variations and the amounts remitted abroad.

PARTICULARS OF FINANCIAL INSTITUTION	ITEM NO	PRICE	CURRENCY	RATE	PORTION OF PRICE SUBJECT TO ROE	AMOUNT IN FOREIGN CURRENCY REMITTED ABROAD
				ZAR=		
				ZAR=		
				ZAR=		
				ZAR=		
				ZAR=		
				ZAR=		

2. Adjustments for rate of exchange variations during the contract period will be calculated by using the average monthly exchange rates as issued by your commercial bank for the periods indicated hereunder: (Proof from bank required)

AVERAGE MONTHLY EXCHANGE RATES FOR THE PERIOD:	DATE DOCUMENTATION MUST BE SUBMITTED TO THIS OFFICE	DATE FROM WHICH NEW CALCULATED PRICES WILL BECOME EFFECTIVE	DATE UNTIL WHICH NEW CALCULATED PRICE WILL BE EFFECTIVE

DECLARATION OF INTEREST

- 1. No bid will be accepted from persons in the service of the state*
- 2. Any person, having a kinship with persons in the service of the state, including a blood relationship, may make an offer or offers in terms of this invitation to bid. In view of possible allegations of favouritism, should the resulting bid, or part thereof, be awarded to persons connected with or related to persons in service of the state, it is required that the bidder or their authorised representative declare their position in relation to the evaluating/adjudicating authority and/or take an oath declaring his/her interest.

3 In order to give effect to the above, the following questionnaire must be completed and submitted with the bid.

3.1 Full Name:

3.2 Identity Number:

3.3 Company Registration Number:

3.4 Tax Reference Number:

3.5 VAT Registration Number:

3.6 Are you presently in the service of the state* **YES / NO**

3.6.1 If so, furnish particulars.

.....

.....

3.7 Have you been in the service of the state for the past twelve months? **YES / NO**

3.7.1 If so, furnish particulars.

.....

.....

*MSCM Regulations: "in the service of the state" means to be –

- (a) a member of –
 - (i) any municipal council;
 - (ii) any provincial legislature; or
 - (iii) the national Assembly or the national Council of provinces;
- (b) a member of the board of directors of any municipal entity;
- (c) an official of any municipality or municipal entity;
- (d) an employee of any national or provincial department, national or provincial public entity or constitutional institution within the meaning of the Public Finance Management Act, 1999 (Act No.1 of 1999);
- (e) a member of the accounting authority of any national or provincial public entity; or
- (f) an employee of Parliament or a provincial legislature.

3.8 Do you, have any relationship (family, friend, other) with
Persons in the service of the state and who may be involved with the
evaluation and or adjudication of this bid?

YES / NO

3.8.1 If so, furnish particulars.

.....
.....

3.9 Are you, aware of any relationship (family, friend, other),
between a bidder and any persons in the service of the state who
may be involved with the evaluation and or adjudication of this
bid?

YES / NO

3.9.1 If so, furnish particulars

.....
.....

3.10 Are any of the company's directors, managers, principal
shareholders or stakeholders in service of the state?

YES / NO

3.10.1 If so, furnish particulars.

.....
.....

3.11 Are any spouse, child or parent of the company's directors,
managers, principal shareholders or stakeholders in service
of the state?

YES / NO

3.11.1 If so, furnish particulars.

.....
.....

CERTIFICATION

I, THE UNDERSIGNED (NAME)

CERTIFY THAT THE INFORMATION FURNISHED ON THIS DECLARATION FORM IS CORRECT.

I ACCEPT THAT THE STATE MAY ACT AGAINST ME SHOULD THIS DECLARATION PROVE TO BE FALSE.

.....
Signature

.....
Date

.....
Position

.....
Name of Bidder

DECLARATION FOR PROCUREMENT ABOVE R10 MILLION (ALL APPLICABLE TAXES INCLUDED)

For all procurement expected to exceed R10 million (all applicable taxes included), bidders must complete the following questionnaire:

1 Are you by law required to prepare annual financial statements for auditing? **YES / NO**

1.1 If yes, submit audited annual financial statements for the past three years or since the date of establishment if established during the past three years.

.....

.....

2 Do you have any outstanding undisputed commitments for municipal services towards any municipality for more than three months or any other service provider in respect of which payment is overdue for more than 30 days? **YES / NO**

2.1. If no, this serves to certify that the bidder has no undisputed commitments for municipal services towards any municipality for more than three months or other service provider in respect of which payment is overdue for more than 30 days.

2.2 If yes, provide particulars.

.....

.....

3 Has any contract been awarded to you by an organ of state during the past five years, including particulars of any material non-compliance or dispute concerning the execution of such contract? **YES / NO**

3.1. If yes, furnish particulars

.....

.....

4 Will any portion of goods or services be sourced from outside the Republic, and, if so, what portion and whether any portion of payment from the municipality / municipal entity is expected to be transferred out of the Republic? ***YES / NO**

4.1 If yes, furnish particulars

.....

.....

* Delete if not applicable

CERTIFICATION

I, THE UNDERSIGNED (NAME)

CERTIFY THAT THE INFORMATION FURNISHED ON THIS DECLARATION FORM IS CORRECT.

I ACCEPT THAT THE STATE MAY ACT AGAINST ME SHOULD THIS DECLARATION PROVE TO BE FALSE.

.....
Signature

.....
Date

.....
Position

.....
Name of Bidder

MBD 6.1

PREFERENCE POINTS CLAIM FORM IN TERMS OF THE PREFERENTIAL PROCUREMENT REGULATIONS 2017

This preference form must form part of all bids invited. It contains general information and serves as a claim form for preference points for Broad-Based Black Economic Empowerment (B-BBEE) Status Level of Contribution

NB: BEFORE COMPLETING THIS FORM, BIDDERS MUST STUDY THE GENERAL CONDITIONS, DEFINITIONS AND DIRECTIVES APPLICABLE IN RESPECT OF B-BBEE, AS PRESCRIBED IN THE PREFERENTIAL PROCUREMENT REGULATIONS, 2017.

1. GENERAL CONDITIONS

1.1 The following preference point systems are applicable to all bids:

- the 80/20 system for requirements with a Rand value of up to R50 000 000 (all applicable taxes included); and
- the 90/10 system for requirements with a Rand value above R50 000 000 (all applicable taxes included).

1.2 The value of this bid is estimated to not exceed R50 000 000 (all applicable taxes included) and therefore the 80/20 preference point system shall be applicable; or

1.3 Points for this bid shall be awarded for:

- (a) Price; and
- (b) B-BBEE Status Level of Contributor.

1.4 The maximum points for this bid are allocated as follows:

	POINTS
PRICE	80
B-BBEE STATUS LEVEL OF CONTRIBUTOR	20
Total points for Price and B-BBEE must not exceed	100

1.5 Failure on the part of a bidder to fill in and/or to sign this form and submit a B-BBEE Verification Certificate from a Verification Agency accredited by the South African Accreditation System (SANAS) or a Registered Auditor approved by the Independent Regulatory Board of Auditors (IRBA) or an Accounting Officer as contemplated in the Close Corporation Act (CCA) together with the bid, will be interpreted to mean that preference points for B-BBEE status level of contribution are not claimed.

1.6 The purchaser reserves the right to require of a bidder, either before a bid is adjudicated or at any time subsequently, to substantiate any claim in regard to preferences, in any manner required by the purchaser.

2. DEFINITIONS

- (a) “**B-BBEE**” means broad-based black economic empowerment as defined in section 1 of the Broad-Based Black Economic Empowerment Act;
- (b) “**B-BBEE status level of contributor**” means the B-BBEE status of an entity in terms of a code of good practice on black economic empowerment, issued in terms of section 9(1) of the Broad-Based Black Economic Empowerment Act;
- (c) “**bid**” means a written offer in a prescribed or stipulated form in response to an invitation by an organ of state for the provision of goods or services, through price quotations, advertised competitive bidding processes or proposals;
- (d) “**Broad-Based Black Economic Empowerment Act**” means the Broad-Based Black Economic Empowerment Act, 2003 (Act No. 53 of 2003);
- (e) “**EME**” means an Exempted Micro Enterprise in terms of a code of good practice on black economic empowerment issued in terms of section 9 (1) of the Broad-Based Black Economic Empowerment Act;
- (f) “**functionality**” means the ability of a tenderer to provide goods or services in accordance with specifications as set out in the tender documents.
- (g) “**prices**” includes all applicable taxes less all unconditional discounts;
- (h) “**proof of B-BBEE status level of contributor**” means:
 - 1) B-BBEE Status level certificate issued by an authorized body or person;
 - 2) A sworn affidavit as prescribed by the B-BBEE Codes of Good Practice;
 - 3) Any other requirement prescribed in terms of the B-BBEE Act;
- (i) “**QSE**” means a qualifying small business enterprise in terms of a code of good practice on black economic empowerment issued in terms of section 9 (1) of the Broad-Based Black Economic Empowerment Act;
- (j) “**rand value**” means the total estimated value of a contract in Rand, calculated at the time of bid invitation, and includes all applicable taxes;

3. POINTS AWARDED FOR PRICE

3.1 THE 80/20 OR 90/10 PREFERENCE POINT SYSTEMS

A maximum of 80 or 90 points is allocated for price on the following basis:

80/20

or

90/10

$$P_s = 80 \left(1 - \frac{P_t - P_{\min}}{P_{\min}} \right) \quad \text{or} \quad P_s = 90 \left(1 - \frac{P_t - P_{\min}}{P_{\min}} \right)$$

Where

Ps = Points scored for price of bid under consideration

Pt = Price of bid under consideration

Pmin = Price of lowest acceptable bid

4. POINTS AWARDED FOR B-BBEE STATUS LEVEL OF CONTRIBUTOR

4.1 In terms of Regulation 6 (2) and 7 (2) of the Preferential Procurement Regulations, preference points must be awarded to a bidder for attaining the B-BBEE status level of contribution in accordance with the table below:

B-BBEE Status Level of Contributor	Number of points (90/10 system)	Number of points (80/20 system)
1	10	20
2	9	18
3	6	14
4	5	12
5	4	8
6	3	6
7	2	4
8	1	2
Non-compliant contributor	0	0

5. BID DECLARATION

5.1 Bidders who claim points in respect of B-BBEE Status Level of Contribution must complete the following:

6. B-BBEE STATUS LEVEL OF CONTRIBUTOR CLAIMED IN TERMS OF PARAGRAPHS 1.4 AND 4.1

6.1 B-BBEE Status Level of Contributor: =(maximum of 10 or 20 points)

(Points claimed in respect of paragraph 7.1 must be in accordance with the table reflected in paragraph 4.1 and must be substantiated by relevant proof of B-BBEE status level of contributor.)

7. SUB-CONTRACTING

7.1 Will any portion of the contract be sub-contracted?

(Tick applicable box)

YES	<input type="checkbox"/>	NO	<input type="checkbox"/>
-----	--------------------------	----	--------------------------

7.1.1 If yes, indicate:

- i) What percentage of the contract will be subcontracted.....%
- ii) The name of the sub-contractor.....
- iii) The B-BBEE status level of the sub-contractor.....
- iv) Whether the sub-contractor is an EME or QSE

(Tick applicable box)

YES	<input type="checkbox"/>	NO	<input type="checkbox"/>
-----	--------------------------	----	--------------------------

- v) Specify, by ticking the appropriate box, if subcontracting with an enterprise in terms of Preferential Procurement Regulations,2017:

Designated Group: An EME or QSE which is at last 51% owned by:	EME √	QSE √
Black people		
Black people who are youth		
Black people who are women		
Black people with disabilities		
Black people living in rural or underdeveloped areas or townships		
Cooperative owned by black people		
Black people who are military veterans		
OR		
Any EME		
Any QSE		

8. DECLARATION WITH REGARD TO COMPANY/FIRM

8.1 Name of company/firm:.....

8.2 VAT registration number:.....

8.3 Company registration number:.....

8.4 TYPE OF COMPANY/ FIRM

- Partnership/Joint Venture / Consortium
- One person business/sole propriety
- Close corporation
- Company
- (Pty) Limited

[TICK APPLICABLE BOX]

8.5 DESCRIBE PRINCIPAL BUSINESS ACTIVITIES

.....

.....

.....

8.6 COMPANY CLASSIFICATION

- Manufacturer
- Supplier
- Professional service provider
- Other service providers, e.g. transporter, etc.

[TICK APPLICABLE BOX]

8.7 MUNICIPAL INFORMATION

Municipality where business is situated:

Registered Account Number:

Stand Number:.....

8.8 Total number of years the company/firm has been in business:.....

8.9 I/we, the undersigned, who is / are duly authorised to do so on behalf of the company/firm, certify that the points claimed, based on the B-BBE status level of contributor indicated in paragraphs 1.4 and 6.1 of the foregoing certificate, qualifies the company/ firm for the preference(s) shown and I / we acknowledge that:

- i) The information furnished is true and correct;
- ii) The preference points claimed are in accordance with the General Conditions as indicated in paragraph 1 of this form;
- iii) In the event of a contract being awarded as a result of points claimed as shown in paragraphs 1.4 and 6.1, the contractor may be required to furnish documentary proof to the satisfaction of the purchaser that the claims are correct;
- iv) If the B-BBEE status level of contributor has been claimed or obtained on a fraudulent basis or any of the conditions of contract have not been fulfilled, the purchaser may, in addition to any other remedy it may have –
 - (a) disqualify the person from the bidding process;
 - (b) recover costs, losses or damages it has incurred or suffered as a result of that person’s conduct;
 - (c) cancel the contract and claim any damages which it has suffered as a result of having to make less favourable arrangements due to such cancellation;
 - (d) recommend that the bidder or contractor, its shareholders and directors, or only the shareholders and directors who acted on a fraudulent basis, be restricted by the National Treasury from obtaining business from any organ of state for a period not exceeding 10 years, after the *audi alteram partem* (hear the other side) rule has been applied; and
 - (e) forward the matter for criminal prosecution.

WITNESSES	
1.
2.

.....	
SIGNATURE(S) OF BIDDERS(S)	
DATE:
ADDRESS

CONTRACT FORM - PURCHASE OF GOODS/WORKS

THIS FORM MUST BE FILLED IN DUPLICATE BY BOTH THE SUCCESSFUL BIDDER (PART 1) AND THE PURCHASER (PART 2). BOTH FORMS MUST BE SIGNED IN THE ORIGINAL SO THAT THE SUCCESSFUL BIDDER AND THE PURCHASER WOULD BE IN POSSESSION OF ORIGINALLY SIGNED CONTRACTS FOR THEIR RESPECTIVE RECORDS.

PART 1 (TO BE FILLED IN BY THE BIDDER)

1. I hereby undertake to supply all or any of the goods and/or works described in the attached bidding documents to (name of institution)..... in accordance with the requirements and specifications stipulated in bid number..... at the price/s quoted. My offer/s remain binding upon me and open for acceptance by the purchaser during the validity period indicated and calculated from the closing time of bid.
2. The following documents shall be deemed to form and be read and construed as part of this agreement:
 - i) Bidding documents, viz
 - Invitation to bid;
 - Tax clearance certificate;
 - Pricing schedule(s);
 - Technical Specification(s);
 - Preference claims for Broad Based Black Economic Empowerment Status Level of Contribution in terms of the Preferential Procurement Regulations 2011;
 - Declaration of interest;
 - Declaration of bidder's past SCM practices;
 - Certificate of Independent Bid Determination;
 - Special Conditions of Contract;
 - ii) General Conditions of Contract; and
 - iii) Other (specify)
3. I confirm that I have satisfied myself as to the correctness and validity of my bid; that the price(s) and rate(s) quoted cover all the goods and/or works specified in the bidding documents; that the price(s) and rate(s) cover all my obligations and I accept that any mistakes regarding price(s) and rate(s) and calculations will be at my own risk.
4. I accept full responsibility for the proper execution and fulfilment of all obligations and conditions devolving on me under this agreement as the principal liable for the due fulfilment of this contract.
5. I declare that I have no participation in any collusive practices with any bidder or any other person regarding this or any other bid.
6. I confirm that I am duly authorised to sign this contract.

NAME (PRINT)

CAPACITY

SIGNATURE

NAME OF FIRM

DATE

WITNESSES
1.
2.
DATE:

CONTRACT FORM - PURCHASE OF GOODS/WORKS

PART 2 (TO BE FILLED IN BY THE PURCHASER)

1. I..... in my capacity as..... accept your bid under reference numberdated.....for the supply of goods/works indicated hereunder and/or further specified in the annexure(s).
2. An official order indicating delivery instructions is forthcoming.
3. I undertake to make payment for the goods/works delivered in accordance with the terms and conditions of the contract, within 30 (thirty) days after receipt of an invoice accompanied by the delivery note.

ITEM NO.	PRICE (ALL APPLICABLE TAXES INCLUDED)	BRAND	DELIVERY PERIOD	B-BBEE STATUS LEVEL OF CONTRIBUTION	MINIMUM THRESHOLD FOR LOCAL PRODUCTION AND CONTENT (if applicable)

4. I confirm that I am duly authorized to sign this contract.

SIGNED AT ON

NAME (PRINT)

SIGNATURE

OFFICIAL STAMP

WITNESSES

1.

2.....

DATE

CONTRACT FORM - RENDERING OF SERVICES

THIS FORM MUST BE FILLED IN DUPLICATE BY BOTH THE SERVICE PROVIDER (PART 1) AND THE PURCHASER (PART 2). BOTH FORMS MUST BE SIGNED IN THE ORIGINAL SO THAT THE SERVICE PROVIDER AND THE PURCHASER WOULD BE IN POSSESSION OF ORIGINALLY SIGNED CONTRACTS FOR THEIR RESPECTIVE RECORDS.

PART 1 (TO BE FILLED IN BY THE SERVICE PROVIDER)

1. I hereby undertake to render services described in the attached bidding documents to (name of the institution)..... in accordance with the requirements and task directives / proposals specifications stipulated in Bid Number..... at the price/s quoted. My offer/s remain binding upon me and open for acceptance by the Purchaser during the validity period indicated and calculated from the closing date of the bid.

2. The following documents shall be deemed to form and be read and construed as part of this agreement:
 - (i) Bidding documents, viz
 - Invitation to bid;
 - Tax clearance certificate;
 - Pricing schedule(s);
 - Filled in task directive/proposal;
 - Preference claims for Broad Based Black Economic Empowerment Status Level of Contribution in terms of the Preferential Procurement Regulations 2011;
 - Declaration of interest;
 - Declaration of Bidder's past SCM practices;
 - Certificate of Independent Bid Determination;
 - Special Conditions of Contract;
 - (ii) General Conditions of Contract; and
 - (iii) Other (specify)

3. I confirm that I have satisfied myself as to the correctness and validity of my bid; that the price(s) and rate(s) quoted cover all the services specified in the bidding documents; that the price(s) and rate(s) cover all my obligations and I accept that any mistakes regarding price(s) and rate(s) and calculations will be at my own risk.

4. I accept full responsibility for the proper execution and fulfilment of all obligations and conditions devolving on me under this agreement as the principal liable for the due fulfilment of this contract.

5. I declare that I have no participation in any collusive practices with any bidder or any other person regarding this or any other bid.

6. I confirm that I am duly authorised to sign this contract.

NAME (PRINT)

CAPACITY

SIGNATURE

NAME OF FIRM

DATE

WITNESSES	
1
2
DATE:

CONTRACT FORM - RENDERING OF SERVICES

PART 2 (TO BE FILLED IN BY THE PURCHASER)

1. I..... in my capacity as..... accept your bid under reference number dated.....for the rendering of services indicated hereunder and/or further specified in the annexure(s).
2. An official order indicating service delivery instructions is forthcoming.
3. I undertake to make payment for the services rendered in accordance with the terms and conditions of the contract, within 30 (thirty) days after receipt of an invoice.

DESCRIPTION OF SERVICE	PRICE (ALL APPLICABLE TAXES INCLUDED)	COMPLETION DATE	B-BBEE STATUS LEVEL OF CONTRIBUTION	MINIMUM THRESHOLD FOR LOCAL PRODUCTION AND CONTENT (if applicable)

4. I confirm that I am duly authorized to sign this contract.

SIGNED AT ON

NAME (PRINT)

SIGNATURE

OFFICIAL STAMP

<p>WITNESSES</p> <p>1</p> <p>2</p> <p>DATE:</p>

DECLARATION OF BIDDER'S PAST SUPPLY CHAIN MANAGEMENT PRACTICES

- 1 This Municipal Bidding Document must form part of all bids invited.
- 2 It serves as a declaration to be used by municipalities and municipal entities in ensuring that when goods and services are being procured, all reasonable steps are taken to combat the abuse of the supply chain management system.
- 3 The bid of any bidder may be rejected if that bidder, or any of its directors have:
 - a. abused the municipality's / municipal entity's supply chain management system or committed any improper conduct in relation to such system;
 - b. been convicted for fraud or corruption during the past five years;
 - c. willfully neglected, reneged on or failed to comply with any government, municipal or other public sector contract during the past five years; or
 - d. been listed in the Register for Tender Defaulters in terms of section 29 of the Prevention and Combating of Corrupt Activities Act (No 12 of 2004).
- 4 **In order to give effect to the above, the following questionnaire must be completed and submitted with the bid.**

Item	Question	Yes	No
4.1	<p>Is the bidder or any of its directors listed on the National Treasury's Database of Restricted Suppliers as companies or persons prohibited from doing business with the public sector?</p> <p>(Companies or persons who are listed on this Database were informed in writing of this restriction by the Accounting Officer/Authority of the institution that imposed the restriction after the <i>audialterampartem</i> rule was applied).</p> <p>The Database of Restricted Suppliers now resides on the National Treasury's website(www.treasury.gov.za) and can be accessed by clicking on its link at the bottom of the home page.</p>	Yes <input type="checkbox"/>	No <input type="checkbox"/>
4.1.1	If so, furnish particulars:		
4.2	<p>Is the bidder or any of its directors listed on the Register for Tender Defaulters in terms of section 29 of the Prevention and Combating of Corrupt Activities Act (No 12 of 2004)?</p> <p>The Register for Tender Defaulters can be accessed on the National Treasury's website (www.treasury.gov.za) by clicking on its link at the bottom of the home page.</p>	Yes <input type="checkbox"/>	No <input type="checkbox"/>
4.2.1	If so, furnish particulars:		
4.3	<p>Was the bidder or any of its directors convicted by a court of law (including a court of law outside the Republic of South Africa) for fraud or corruption during the past five years?</p>	Yes <input type="checkbox"/>	No <input type="checkbox"/>

4.3.1	If so, furnish particulars:		
Item	Question	Yes	No
4.4	Does the bidder or any of its directors owe any municipal rates and taxes or municipal charges to the municipality / municipal entity, or to any other municipality / municipal entity, that is in arrears for more than three months?	Yes <input type="checkbox"/>	No <input type="checkbox"/>
4.4.1	If so, furnish particulars:		
4.5	Was any contract between the bidder and the municipality / municipal entity or any other organ of state terminated during the past five years on account of failure to perform on or comply with the contract?	Yes <input type="checkbox"/>	No <input type="checkbox"/>
4.7.1	If so, furnish particulars:		

CERTIFICATION

**I, THE UNDERSIGNED (FULL NAME)
 CERTIFY THAT THE INFORMATION FURNISHED ON THIS DECLARATION FORM TRUE
 AND CORRECT.**

**I ACCEPT THAT, IN ADDITION TO CANCELLATION OF A CONTRACT, ACTION MAY BE
 TAKEN AGAINST ME SHOULD THIS DECLARATION PROVE TO BE FALSE.**

.....
Signature

.....
Date

.....
Position

.....
Name of Bidder

CERTIFICATE OF INDEPENDENT BID DETERMINATION

- 1 This Municipal Bidding Document (MBD) must form part of all bids¹ invited.
- 2 Section 4 (1) (b) (iii) of the Competition Act No. 89 of 1998, as amended, prohibits an agreement between, or concerted practice by, firms, or a decision by an association of firms, if it is between parties in a horizontal relationship and if it involves collusive bidding (or bid rigging).² Collusive bidding is a *per se* prohibition meaning that it cannot be justified under any grounds.
- 3 Municipal Supply Regulation 38 (1) prescribes that a supply chain management policy must provide measures for the combating of abuse of the supply chain management system, and must enable the accounting officer, among others, to:
 - a. take all reasonable steps to prevent such abuse;
 - b. reject the bid of any bidder if that bidder or any of its directors has abused the supply chain management system of the municipality or municipal entity or has committed any improper conduct in relation to such system; and
 - c. cancel a contract awarded to a person if the person committed any corrupt or fraudulent act during the bidding process or the execution of the contract.

This MBD serves as a certificate of declaration that would be used by institutions to ensure that, when bids are considered, reasonable steps are taken to prevent any form of bid-rigging.

- 4 In order to give effect to the above, the attached Certificate of Bid Determination (MBD 9) must be completed and submitted with the bid:

¹ Includes price quotations, advertised competitive bids, limited bids and proposals.

² Bid rigging (or collusive bidding) occurs when businesses, that would otherwise be expected to compete, secretly conspire to raise prices or lower the quality of goods and / or services for purchasers who wish to acquire goods and / or services through a bidding process. Bid rigging is, therefore, an agreement between competitors not to compete.

CERTIFICATE OF INDEPENDENT BID DETERMINATION

I, the undersigned, in submitting the accompanying bid:

(Bid Number and Description)

in response to the invitation for the bid made by:

(Name of Municipality / Municipal Entity)

do hereby make the following statements that I certify to be true and complete in every respect:

I certify, on behalf of: _____ that:
(Name of Bidder)

1. I have read and I understand the contents of this Certificate;
2. I understand that the accompanying bid will be disqualified if this Certificate is found not to be true and complete in every respect;
3. I am authorized by the bidder to sign this Certificate, and to submit the accompanying bid, on behalf of the bidder;
4. Each person whose signature appears on the accompanying bid has been authorized by the bidder to determine the terms of, and to sign, the bid, on behalf of the bidder;
5. For the purposes of this Certificate and the accompanying bid, I understand that the word "competitor" shall include any individual or organization, other than the bidder, whether or not affiliated with the bidder, who:
 - (a) has been requested to submit a bid in response to this bid invitation;
 - (b) could potentially submit a bid in response to this bid invitation, based on their qualifications, abilities or experience; and
 - (c) provides the same goods and services as the bidder and/or is in the same line of business as the bidder
6. The bidder has arrived at the accompanying bid independently from, and without consultation, communication, agreement or arrangement with any competitor. However communication between partners in a joint venture or consortium³ will not be construed as collusive bidding

- 7. In particular, without limiting the generality of paragraphs 6 above, there has been no consultation, communication, agreement or arrangement with any competitor regarding:
 - (a) prices;
 - (b) geographical area where product or service will be rendered (market allocation)
 - (c) Methods, factors or formulas used to calculate prices;
 - (d) the intention or decision to submit or not to submit, a bid;
 - (e) the submission of a bid which does not meet the specifications and conditions of the bid; or
 - (f) Bidding with the intention not to win the bid.
- 8. In addition, there have been no consultations, communications, agreements or arrangements with any competitor regarding the quality, quantity, specifications and conditions or delivery particulars of the products or services to which this bid invitation relates.
- 9. The terms of the accompanying bid have not been, and will not be, disclosed by the bidder, directly or indirectly, to any competitor, prior to the date and time of the official bid opening or of the awarding of the contract.
- 10. I am aware that, in addition and without prejudice to any other remedy provided to combat any restrictive practices related to bids and contracts, bids that are suspicious will be reported to the Competition Commission for investigation and possible imposition of administrative penalties in terms of section 59 of the Competition Act No 89 of 1998 and or may be reported to the National Prosecuting Authority (NPA) for criminal investigation and or may be restricted from conducting business with the public sector for a period not exceeding ten (10) years in terms of the Prevention and Combating of Corrupt Activities Act No 12 of 2004 or any other applicable legislation.

.....
Signature

.....
Date

.....
Position

.....
Name of Bidder

³ Joint venture or Consortium means an association of persons for the purpose of combining their expertise, property, capital, efforts, skill and knowledge in an activity for the execution of a contract.



CAPRICORN DISTRICT MUNICIPALITY

C1.1 Form of Offer and Acceptance – Contract C

Offer

The employer, identified in the acceptance signature block, has solicited offers to enter into a contract for the procurement of:

BID NUMBER : INF-W02/2022/2023 : NAIRIN VILLAGEWATER SUPPLY (BLOUBERG)

The Bidder, identified in the offer signature block, has examined the documents listed in the Bid data and addenda thereto as listed in the returnable schedules, and by submitting this offer has accepted the conditions of Bid.

By the representative of the Bidder, deemed to be duly authorized, signing this part of this form of offer and acceptance, the Bidder offers to perform all of the obligations and liabilities of the contractor under the contract including compliance with all its terms and conditions according to their true intent and meaning for an amount to be determined in accordance with the conditions of contract identified in the contract data.

THE OFFERED TOTAL OF THE PRICES INCLUSIVE OF VALUE ADDED TAX IS:

..... Rand (in words);

R (in figures)

This offer may be accepted by the employer by signing the acceptance part of this form of offer and acceptance and returning one copy of this document to the Bidder before the end of the period of validity stated in the Bid data, whereupon the Bidder becomes the party named as the contractor in the conditions of contract identified in the contract data.

Signature Date

Name

Capacity

for the Bidder

(Name and address of organization)

Name and signature of witness

Acceptance

By signing this part of this form of offer and acceptance, the employer identified below accepts the Bidder's offer. In consideration thereof, the employer shall pay the contractor the amount due in accordance with the conditions of contract identified in the contract data. Acceptance of the Bidder's offer shall form an agreement between the employer and the Bidder upon the terms and conditions contained in this agreement and in the contract that is the subject of this agreement.

The terms of the contract, are contained in:

- Part C1: Agreements and contract data, (which includes this agreement)
- Part C2: Pricing data

Part C3: Scope of work.
Part C4: Site information

and drawings and documents or parts thereof, which may be incorporated by reference into Parts 1 to 4 above.

Deviations from and amendments to the documents listed in the Bid data and any addenda thereto as listed in the Bid schedules as well as any changes to the terms of the offer agreed by the Bidder and the employer during this process of offer and acceptance, are contained in the schedule of deviations attached to and forming part of this agreement. No amendments to or deviations from said documents are valid unless contained in this schedule.

The Bidder shall within two weeks after receiving a completed copy of this agreement, including the schedule of deviations (if any), contact the employer's agent (whose details are given in the contract data) to arrange the delivery of any bonds, guarantees, proof of insurance and any other documentation to be provided in terms of the conditions of contract identified in the contract data. Failure to fulfil any of these obligations in accordance with those terms shall constitute a repudiation of this agreement.

Notwithstanding anything contained herein, this agreement comes into effect on the date when the Bidder receives one fully completed original copy of this document, including the schedule of deviations (if any). Unless the Bidder (now contractor) within five working days of the date of such receipt notifies the employer in writing of any reason why he cannot accept the contents of this agreement, this agreement shall constitute a binding contract between the parties.

Signature Date

Name

Capacity

for the Employer

CAPRICORN DISTRICT MUNICIPALITY
P O Box 4100, Polokwane, 0700
41 Biccard Street

Name and signature of witness Date

.....

Schedule of Deviations

1 Subject

Details

.....

.....

.....

2 Subject

Details

.....

.....

.....

3 Subject

Details

.....

.....

.....

4 Subject

Details

.....

.....

.....

5 Subject

Details

.....

.....

.....

By the duly authorised representatives signing this agreement, the employer and the Bidder agree to and accept the foregoing schedule of deviations as the only deviations from and amendments to the documents listed in the Bid data and addenda thereto as listed in the Bid schedules, as well as any confirmation, clarification or changes to the terms of the offer agreed by the Bidder and the employer during this process of offer and acceptance.

It is expressly agreed that no other matter whether in writing, oral communication or implied during the period between the issue of the Bid documents and the receipt by the Bidder of a completed signed copy of this Agreement shall have any meaning or effect in the contract between the parties arising from this agreement.



CAPRICORN DISTRICT MUNICIPALITY

C1.2 Contract Data

The General Conditions of Contract for Construction Works, Third Edition (2015) published by the South African Institution of Civil Engineering, are applicable to this contract and forms Volume 1 of the Contract Document. Volume 2 is the Contract Drawings Copies of these conditions of contract may be obtained from the South African Institution of Civil Engineering (Tel: 011-805 5947).

The General Conditions of Contract for Construction Works make several references to the Contract Data for specific data, which together with these conditions collectively describe the risks, liabilities and obligations of the contracting parties and the procedures for the administration of the Contract. The Contract Data shall have precedence in the interpretation of any ambiguity or inconsistency between it and the general conditions of contract.

Each item of data given below is cross-referenced to the clause in the General Conditions of Contract for Construction Works to which it mainly applies.

	<p>The additional clauses to the General Conditions of Contract are:</p> <p>Payment for the labour-intensive component of the works</p> <p>Payment for works identified in the Scope of Work as being labour-intensive shall only be made in accordance with the provisions of the Contract if the works are constructed strictly in accordance with the provisions of the scope of work. Any non-payment for such works shall not relieve the Contractor in any way from his obligations either in contract or in delict.</p> <p>Linkage of payment for labour-intensive component of works to submission of project data</p> <p>The Contractor's payment invoices shall be accompanied by labour information for the corresponding period in a format specified by the employer. If the contractor chooses to delay submitting payment invoices, labour returns shall still be submitted as per frequency and timeframe stipulated by the Employer. The contractor's invoices shall not be paid until all pending labour information has been submitted.</p> <p>Applicable labour laws</p> <p>The current Ministerial Determination (also downloadable at www.epwp.gov.za), Expanded Public Works Programmes, issued in terms of the Basic Condition of Employment Act of 1997 by the Minister of Labour in Government Notice, shall apply to works described in the scope of work as being labour-intensive and which are undertaken by unskilled workers.</p> <p>1 Introduction</p> <p>1.1 This document contains the standard terms and conditions for workers employed in elementary occupations on a Special Public Works Programme (SPWP). These terms and conditions do NOT apply to persons employed in the supervision and management of a SPWP.</p> <p>4.2 In this document –</p> <ul style="list-style-type: none"> (a) “department” means any department of the State, implementing agent or contractor; (b) “employer” means any department, implementing agency or contractor that hires workers to work in elementary occupations on a SPWP; (c) “worker” means any person working in an elementary occupation on a SPWP; (d) “elementary occupation” means any occupation involving unskilled or semi-skilled work; (e) “management” means any person employed by a department or implementing agency to administer or execute an SPWP; (f) “task” means a fixed quantity of work;
--	--

- (g) "task-based work" means work in which a worker is paid a fixed rate for performing a task;
- (h) "task-rated worker" means a worker paid on the basis of the number of tasks completed;
- (i) "time-rated worker" means a worker paid on the basis of the length of time worked.

2 Terms of Work

- 2.1 Workers on a SPWP are employed on a temporary basis.
- 2.2 A worker may NOT be employed for longer than 24 months in any five-year cycle on a SPWP.
- 2.3 Employment on a SPWP does not qualify as employment as a contributor for the purposes of the Unemployment Insurance Act 30 of 1966.

3 Normal Hours of Work

- 3.1 An employer may not set tasks or hours of work that require a worker to work–
 - (a) more than forty hours in any week
 - (b) on more than five days in any week; and
 - (c) for more than eight hours on any day.
- 3.2 An employer and worker may agree that a worker will work four days per week. The worker may then work up to ten hours per day.
- 3.3 A task-rated worker may not work more than a total of 55 hours in any week to complete the tasks allocated (based on a 40-hour week) to that worker.

4 Meal Breaks

- 4.1 A worker may not work for more than five hours without taking a meal break of at least thirty minutes duration.
- 4.2 An employer and worker may agree on longer meal breaks.
- 4.3 A worker may not work during a meal break. However, an employer may require a worker to perform duties during a meal break if those duties cannot be left unattended and cannot be performed by another worker. An employer must take reasonable steps to ensure that a worker is relieved of his or her duties during the meal break.
- 4.4 A worker is not entitled to payment for the period of a meal break. However, a worker who is paid on the basis of time worked must be paid if the worker is required to work or to be available for work during the meal break.

5 Special Conditions for Security Guards

- 5.1 A security guard may work up to 55 hours per week and up to eleven hours per day.
- 5.2 A security guard who works more than ten hours per day must have a meal break of at least one hour or two breaks of at least 30 minutes each.

6 Daily Rest Period

Every worker is entitled to a daily rest period of at least eight consecutive hours. The daily rest period is measured from the time the worker ends work on one day until the time the worker starts work on the next day.

7 Weekly Rest Period

Every worker must have two days off every week. A worker may only work on their day off to perform work which must be done without delay and cannot be performed by workers during their ordinary hours of work ("emergency work").

8 Work on Sundays and Public Holidays

- 8.1 A worker may only work on a Sunday or public holiday to perform emergency or security work.
- 8.2 Work on Sundays is paid at the ordinary rate of pay.
- 8.3 A task-rated worker who works on a public holiday must be paid –
 - (a) the worker's daily task rate, if the worker works for less than four hours;
 - (b) double the worker's daily task rate, if the worker works for more than four hours.
- 8.4 A time-rated worker who works on a public holiday must be paid –
 - (a) the worker's daily rate of pay, if the worker works for less than four hours on the public holiday;
 - (b) double the worker's daily rate of pay, if the worker works for more than four hours on the public holiday.

9 Sick Leave

- 9.1 Only workers who work four or more days per week have the right to claim sick-pay in terms of this clause.

- 9.2 A worker who is unable to work on account of illness or injury is entitled to claim one day's paid sick leave for every full month that the worker has worked in terms of a contract.
- 9.3 A worker may accumulate a maximum of twelve days' sick leave in a year.
- 9.4 Accumulated sick-leave may not be transferred from one contract to another contract.
- 9.5 An employer must pay a task-rated worker the worker's daily task rate for a day's sick leave.
- 9.6 An employer must pay a time-rated worker the worker's daily rate of pay for a day's sick leave.
- 9.7 An employer must pay a worker sick pay on the worker's usual payday.
- 9.8 Before paying sick-pay, an employer may require a worker to produce a certificate stating that the worker was unable to work on account of sickness or injury if the worker is –
- (a) absent from work for more than two consecutive days; or
 - (b) absent from work on more than two occasions in any eight-week period.
- 9.9 A medical certificate must be issued and signed by a medical practitioner, a qualified nurse or a clinic staff member authorised to issue medical certificates indicating the duration and reason for incapacity.
- 9.10 A worker is not entitled to paid sick-leave for a work-related injury or occupational disease for which the worker can claim compensation under the Compensation for Occupational Injuries and Diseases Act.
- 10 Maternity Leave**
- 10.1 A worker may take up to four consecutive months' unpaid maternity leave.
- 10.2 A worker is not entitled to any payment or employment-related benefits during maternity leave.
- 10.3 A worker must give her employer reasonable notice of when she will start maternity leave and when she will return to work.
- 10.4 A worker is not required to take the full period of maternity leave. However, a worker may not work for four weeks before the expected date of birth of her child or for six weeks after the birth of her child, unless a medical practitioner, midwife or qualified nurse certifies that she is fit to do so.
- 10.5 A worker may begin maternity leave –
- (a) four weeks before the expected date of birth; or
 - (b) on an earlier date –
 - (i) if a medical practitioner, midwife or certified nurse certifies that it is necessary for the health of the worker or that of her unborn child; or
 - (ii) if agreed to between employer and worker; or
 - (c) on a later date, if a medical practitioner, midwife or certified nurse has certified that the worker is able to continue to work without endangering her health.
- 10.6 A worker who has a miscarriage during the third trimester of pregnancy or bears a stillborn child may take maternity leave for up to six weeks after the miscarriage or stillbirth.
- 10.7 A worker who returns to work after maternity leave, has the right to start a new cycle of twenty-four months employment, unless the SPWP on which she was employed has ended.
- 11 Family responsibility leave**
- 11.1 Workers, who work for at least four days per week, are entitled to three days paid family responsibility leave each year in the following circumstances -
- (a) when the employee's child is born;
 - (b) when the employee's child is sick;
 - (c) in the event of a death of –
 - (i) the employee's spouse or life partner;
 - (ii) the employee's parent, adoptive parent, grandparent, child, adopted child, grandchild or sibling.
- 12 Statement of Conditions**
- 12.1 An employer must give a worker a statement containing the following details at the start of employment –
- (a) the employer's name and address and the name of the SPWP;
 - (b) the tasks or job that the worker is to perform; and
 - (c) the period for which the worker is hired or, if this is not certain, the expected duration of the contract;
 - (d) the worker's rate of pay and how this is to be calculated;
 - (e) the training that the worker will receive during the SPWP.
- 12.2 An employer must ensure that these terms are explained in a suitable language to any employee who is unable to read the statement.
- 12.3 An employer must supply each worker with a copy of these conditions of employment.
- 13 Keeping Records**
- 13.1 Every employer must keep a written record of at least the following –
- (a) the worker's name and position;
 - (b) in the case of a task-rated worker, the number of tasks completed by the worker;
 - (c) in the case of a time-rated worker, the time worked by the worker;
 - (d) payments made to each worker.

13.2 The employer must keep this record for a period of at least three years after the completion of the SPWP.

14 Payment

14.1 An employer must pay all wages at least monthly in cash or by cheque or into a bank account.

14.2 A task-rated worker will only be paid for tasks that have been completed.

14.3 An employer must pay a task-rated worker within five weeks of the work being completed and the work having been approved by the manager or the contractor having submitted an invoice to the employer.

14.4 A time-rated worker will be paid at the end of each month.

14.5 Payment must be made in cash, by cheque or by direct deposit into a bank account designated by the worker.

14.6 Payment in cash or by cheque must take place –

- (a) at the workplace or at a place agreed to by the worker;
- (b) during the worker's working hours or within fifteen minutes of the start or finish of work;
- (c) in a sealed envelope which becomes the property of the worker.

14.7 An employer must give a worker the following information in writing –

- (a) the period for which payment is made;
- (b) the numbers of tasks completed or hours worked;
- (c) the worker's earnings;
- (d) any money deducted from the payment;
- (e) the actual amount paid to the worker.

14.8 If the worker is paid in cash or by cheque, this information must be recorded on the envelope and the worker must acknowledge receipt of payment by signing for it

14.9 If a worker's employment is terminated, the employer must pay all monies owing to that worker within one month of the termination of employment.

15 Deductions

15.1 An employer may not deduct money from a worker's payment unless the deduction is required in terms of a law.

15.2 An employer must deduct and pay to the SA Revenue Services any income tax that the worker is required to pay.

15.3 An employer who deducts money from a worker's pay for payment to another person must pay the money to that person within the time period and other requirements specified in the agreement law, court order or arbitration award concerned.

15.4 An employer may not require or allow a worker to –

- (a) repay any payment except an overpayment previously made by the employer by mistake;
- (b) state that the worker received a greater amount of money than the employer actually paid to the worker; or
- (f) pay the employer or any other person for having been employed.

16 Health and Safety

16.1 Employers must take all reasonable steps to ensure that the working environment is healthy and safe.

16.2 A worker must –

- (a) work in a way that does not endanger his/her health and safety or that of any other person;
- (b) obey any health and safety instruction;
- (c) obey all health and safety rules of the SPWP;
- (d) use any personal protective equipment or clothing issued by the employer;
- (e) report any accident, near-miss incident or dangerous behaviour by another person to their employer or manager.

17 Compensation for Injuries and Diseases

17.1 It is the responsibility of the employers (other than a contractor) to arrange for all persons employed on a SPWP to be covered in terms of the Compensation for Occupational Injuries and Diseases Act, 130 of 1993.

17.2 A worker must report any work-related injury or occupational disease to their employer or manager.

17.3 The employer must report the accident or disease to the Compensation Commissioner.

17.4 An employer must pay a worker who is unable to work because of an injury caused by an accident at work 75% of their earnings for up to three months. The employer will be refunded this amount by the Compensation Commissioner. This does NOT apply to injuries caused by accidents outside the workplace such as road accidents or accidents at home.

18 Termination

18.1 The employer may terminate the employment of a worker for good cause after following a fair procedure.

18.2 A worker will not receive severance pay on termination.

18.3 A worker is not required to give notice to terminate employment. However, a worker who wishes to resign should advise the employer in advance to allow the employer to find a replacement.

18.4 A worker who is absent for more than three consecutive days without informing the employer of an intention to return to work will have terminated the contract. However, the worker may be re-engaged if a position becomes available for the balance of the 24-month period.

18.5 A worker who does not attend required training events, without good reason, will have terminated the contract. However, the worker may be re-engaged if a position becomes available for the balance of the 24-month period.

19 Certificate of Service

19.1 On termination of employment, a worker is entitled to a certificate stating –

- (a) the worker's full name;
- (b) the name and address of the employer;
- (c) the SPWP on which the worker worked;
- (d) the work performed by the worker;
- (e) any training received by the worker as part of the SPWP;
- (f) the period for which the worker worked on the SPWP;
- (g) any other information agreed on by the employer and worker.

Part 1: Contract Data completed by the Employer

Clause	
1.1.1.13	The Defects Liability Period is 12 calendar months after the final completion date
1.1.1.14	The times for achieving Practical Completion is twelve (12) months after commencement date
1.1.5	Clause 1.1.5 of the GCC is replaced by the following: The "Commencement date" shall be the date the site is handed over to the Contractor.
1.1.15	The name of the Employer is the Capricorn District Municipality .
1.2.1.2	<p>The address of the Employer is: Telephone: 015 294 1000 Facsimile : 015 295 4000</p> <p>Address : 41 Biccard Street Address : P.O Box 4100, Polokwane, 0700</p>
1.1.16	The Employer's Agent representing the Consultant is Andrew tendayi
1.2.1.2	<p>The engineer's address for receipt of communication is SADC PROJECT CONSULTING (PTY) LTD & ORBITALS TRADING AND PROJECTS JV Stand No 19A, Church Street, Polokwane,0700</p> <p>Cell: 071 413 7467 Email: info@orbitals.co.za</p>
5.3.1	<p>The documentation required before commencement with works execution are:</p> <ol style="list-style-type: none"> 1.Health and Safety Plan 2.Initial Programme 3.Security 4.Insurance
5.3.2	The time to submit the documentation required before commencement with works execution is 14 days of the Commencement Date.
5.8.1	The special non-working days are public holidays, Saturdays, Sundays and the days on which the contractor grants the majority of his permanent workforce leave around the 15 th December and the first Monday of the subsequent year.
5.13.1	The penalty for failing to complete the Works is 1.5% of the contract amount per month .
5.16.3	The latent defect period is Ten(10) years
6.5.1.2.3	The percentage allowance to cover overhead charges is 15%
6.10.1.5	The percentage advance on materials not yet built into the Permanent Works is 80%
6.10.3	A Retention Money Guarantee is NOT permitted. 10% of each interim payment claim value will be retained by the Employer to completion. Retention will be released in terms of the relevant GCC 2015 3rd Edition relevant clauses.
8.6.1.1.2	The Value of Plant and material supplied by the employer to be included in the insurance sum is R0.00
8.6.1.1.3	The amount to cover professional fees for repairing damage and loss included in the insurance sum is as per SLA signed with the client
8.6.1.3	The limit of indemnity for liability insurance is as per SLA signed with the client.
10.5.3	The number of adjudication Board Members to be appointed is as per client structures
3.1.3	<p>The engineer is required in terms of his appointment with the employer to obtain the following specific approvals from the employer: e.g.</p> <ol style="list-style-type: none"> 1. Approval of extension of time; 2. Approval of additional costs; 3. Approval of variation orders; 4. Approval of penalties; 5. Approval from Capricorn District Municipality for the utilization of any Contingencies

3.1.3	<p>The Engineer is required to obtain the specific approval of the Employer before executing any of the following functions or duties:</p> <ol style="list-style-type: none"> 1. Nominating the Engineer's Representative in terms of Clause 3.2.1. 2. Delegation of Engineer's authority in terms of Clause 3.2.4. 3. Providing consent for subcontracting part of the contract in terms of Clause 4.4.3. 4. The issuing of further drawings or instructions in terms of Clause 5.9.1. 5. The issuing of instructions for dealing with fossils and the like in terms of Clause 4.7.1. 6. Authorizing the Contractor to repair and make good excepted risks in terms of Clause 8.3. 7. The issuing of a variation order in terms of Clause 6.3.1. 8. Issuing of instructions to carry out work on a day work basis in terms of Clause 6.5. 9. Granting permission to work during non-working times in terms of Clause 38.1. 10. Suspend the progress of the works in terms of Clause 5.11.1 11. The issuing of an instruction to accelerate progress in terms of Clause 5.7.3. 12. The reduction of a penalty for delay in terms of Clause 5.13.2. 10. The determination of additional or reduced costs arising from changes in legislation in terms of Clause 6.8.2. 11. The giving of a ruling on a contractor's claim in terms of Clause 10.1.5. 12. The agreeing of an extension to the 28 day period in terms of Clause 10.1.5. 13. The inclusion of credits in the next payment certificate in terms of Clause 5.12.3.
5.3.1	<p>The time to deliver the Form of Guarantee within 14 days of the Commencement Date. The Form of Guarantee is to contain the wording of the document included in Clause 3 or as supplied by the Employer. The liability for the guarantee shall be for 10% of the contract amount.</p>
5.3.2	<p>The time to submit the documentation required before commencement with works execution is 14 days of the Commencement Date.</p>
5.6.1	<p>The Works programme is to be delivered within 14 days of the Commencement Date.</p>
8.6.1.1	<p>The amount to be included in the sum insured to cover the value of the contract</p>
8.6.1.2	<p>Contractor to provide ALL RISK insurance within 14 days of award.</p>
5.14	<p>The works shall be completed within a maximum of Twelve (12) consecutive months and also as per the ruling GCC</p>
5.13.1	<p>The penalty for failing to complete the Works is 1.5% of the contract amount per month, and or part thereof.</p>
6.8.2	<p>The value of the payment certificates is to be adjusted in accordance with the Contract Price Adjustment Schedule, where: , where:</p> <p style="padding-left: 40px;">The value of "x" is 0,15</p> <p style="padding-left: 40px;">The values of the coefficients are: a = 0.15 (Labour) b = 0.20 (Contractor's equipment) c = 0.55 (Material) d = 0.10 (Fuel)</p> <p style="padding-left: 40px;">The urban area nearest to the Site is Polokwane The base month is the month prior to the closing of the Bid, i.e. 23rd of JULY 2022</p>
6.10.3	<p>The percentage retention on amounts due to the Contractor is 10% of the contract amount.</p> <p>A Retention Money Guarantee is NOT permitted. 10% of each interim payment certificate value will be deducted to completion and released in terms of the GCC 2015 Third Edition conditions</p>
6.10.1	<p>Minimum amount of interim payment certificate is R 200 000.00</p>

10.4	Dispute resolution is to be my means of amicable settlement.
10.4	Dispute resolution is to be my means of amicable settlement.
10.7.1	Disputes are to be referred for final settlement to court proceedings.
	<p>Payment for labour-intensive component of the works</p> <p>Payment for works identified in the Scope of Works as being labour-intensive shall only be made in accordance with the provisions of the Contract if the works are constructed strictly in accordance with the provisions of the Scope of Work. Any payment for such works shall not relieve the Contractor in any way from his obligations either in contract or in delict.</p>
	<p>Linkage of payment for labour-intensive component of works to submission of project data</p> <p>The Contractor's payment invoices shall be accompanied by labour information for the corresponding period in a format specified by the employer. If the contractor chooses to delay submitting payment invoices, labour returns shall still be submitted as per frequency and timeframe stipulated by the Employer. The contractor's invoices shall not be paid until all pending labour information has been submitted.</p>
	<p>Applicable Labour Laws</p> <p>The current Ministerial Determination (also downloadable at www.epwp.gov.za), Expanded Public Works Programmes, issued in terms of the Basic Condition of Employment Act of 1997 by the Minister of Labour in Government Notice, shall apply to works described in the scope of work as being labour-intensive and which are undertaken by unskilled workers.</p>
Special Clause in terms of RDP	<p>Requirements in terms of government's reconstruction and development programme.</p> <p>Target values</p> <p>In this contract the minimum target values shall be as follows:</p> <p style="margin-left: 40px;">Labour Maximisation : 6%</p> <p style="margin-left: 40px;">ABE support : 10%</p> <p style="margin-left: 40px;">HDI Supervisory Staff : 10%</p> <p>The penalties for not reaching the required target values will be calculated at 20% of the difference between the set target values and the actual target values achieved by the contractor at completion of the works. No bonuses for achieving the set target values are applicable.</p>
Special Clause in terms of the Preferential Procurement Policy Framework Act: Preferential Procurement Regulations	<p>Subcontracting as condition of tender</p> <p>The successful tenderer must subcontract a minimum of 30% of the value of the contract to:</p> <ol style="list-style-type: none"> (a) an EME or QSE which is at least 51% owned by black people; (b) an EME or QSE which is at least 51% owned by black people who are youth; (c) an EME or QSE which is at least 51% owned by black people who are women; (d) an EME or QSE which is at least 51% owned by black people with disabilities; (e) an EME or QSE which is 51% owned by black people living in rural or underdeveloped areas or townships; (f) a cooperative which is at least 51% owned by black people; (g) an EME (h) or QSE which is at least 51% owned by black people who are military (i) veterans; or (j) more than one of the categories referred to in paragraphs (a) to (h). <p style="margin-left: 40px;">"EME" – Exempted Micro Enterprise</p> <p style="margin-left: 40px;">"QSE" – Qualifying Small Business Enterprise"</p>

Part 2: Data provided by the Contractor

Clause																															
1.1.1.9	The contractor is																														
1.2.1.2	The contractor's address for receipt of communication is: Telephone: Mobile phone: Facsimile:..... e-mail: Address:																														
1.1.1.14	The time for achieving Practical Completion is.....																														
6.2.1	<table border="1"> <thead> <tr> <th>Type of Security <i>(Value Added Tax is excluded from the Contract Sum and the Value of the Works for Calculating the percentage)</i></th> <th>Contractor's Choice. Indicate "Yes or No"</th> </tr> </thead> <tbody> <tr> <td>Cash deposits of 10% of the contract Sum.</td> <td></td> </tr> <tr> <td>Performance guarantee of 10% of the contract Sum.</td> <td></td> </tr> <tr> <td>Retention of 10% of the value of the works</td> <td></td> </tr> <tr> <td>Cash Deposits of 10 % of the contract Sum plus retention of 10% of the value of the works</td> <td></td> </tr> <tr> <td>Performance guarantee of 10% of the contract Sum plus retention of 10%of the value of the works</td> <td></td> </tr> </tbody> </table>	Type of Security <i>(Value Added Tax is excluded from the Contract Sum and the Value of the Works for Calculating the percentage)</i>	Contractor's Choice. Indicate "Yes or No"	Cash deposits of 10% of the contract Sum.		Performance guarantee of 10% of the contract Sum.		Retention of 10% of the value of the works		Cash Deposits of 10 % of the contract Sum plus retention of 10% of the value of the works		Performance guarantee of 10% of the contract Sum plus retention of 10%of the value of the works																			
Type of Security <i>(Value Added Tax is excluded from the Contract Sum and the Value of the Works for Calculating the percentage)</i>	Contractor's Choice. Indicate "Yes or No"																														
Cash deposits of 10% of the contract Sum.																															
Performance guarantee of 10% of the contract Sum.																															
Retention of 10% of the value of the works																															
Cash Deposits of 10 % of the contract Sum plus retention of 10% of the value of the works																															
Performance guarantee of 10% of the contract Sum plus retention of 10%of the value of the works																															
6.5.1.2.3	The percentage allowances to cover all charges for the contractor's and subcontractor's profits, timekeeping, clerical work, insurance, establishment, superintendence and the use of hand tools is%.																														
6.8.3	The variation in cost of special materials is: <table border="1"> <thead> <tr> <th rowspan="2">Special material</th> <th colspan="2">Unit on which variation will be determined</th> <th rowspan="2">Price for base month ex-factory, excluding transport, labour or any other costs.</th> </tr> <tr> <th>Containers</th> <th>Delivered in bulk</th> </tr> </thead> <tbody> <tr> <td></td> <td></td> <td></td> <td></td> </tr> <tr> <td></td> <td></td> <td></td> <td></td> </tr> <tr> <td></td> <td></td> <td></td> <td></td> </tr> <tr> <td></td> <td></td> <td></td> <td></td> </tr> <tr> <td></td> <td></td> <td></td> <td></td> </tr> <tr> <td></td> <td></td> <td></td> <td></td> </tr> </tbody> </table> <p>*State unit in appropriate column</p>	Special material	Unit on which variation will be determined		Price for base month ex-factory, excluding transport, labour or any other costs.	Containers	Delivered in bulk																								
Special material	Unit on which variation will be determined		Price for base month ex-factory, excluding transport, labour or any other costs.																												
	Containers	Delivered in bulk																													



CAPRICORN DISTRICT MUNICIPALITY

C1.3 Form of Guarantee

Bid Number : INF-W02/2022/2023

PERFORMANCE GUARANTEE

(not to be completed at bid stage)

To: (whom the Contract defines as the Employer)

Address:
.....
.....

DEFINITIONS AND DETAILS

“Guarantor” means:

Physical address:

“Employer: means:

“Contractor” means:.....

“Engineer” means:

“Works” means:

“Site” means:

“Contract” means: The Agreement made in terms of the Form of Offer and Acceptance and such amendments or additions to the Contract as may be agreed in writing between the parties.

The description of the Contract is:
.....
.....

“Contract Sum” means: The accepted amount inclusive of tax of R.....

Amount in words:

“Guaranteed Sum” means: The maximum aggregate amount of R.....

Amount in words:

PERFORMANCE GUARANTEE

1. The Guarantor's liability shall be limited to the amount of the Guaranteed Sum.
2. The Guarantor's period of liability shall be from and including the date of issue of this Performance Guarantee and up to the date of issue by the Engineer of the Certificate of Completion of the Works or the date of payment in full of the Guaranteed Sum, whichever occurs first. The Engineer and/or the Employer shall advise the Guarantor in writing of the date on which the Certificate of Completion of the Works has been issued.
3. The Guarantor hereby acknowledges that:
 - 3.1 any reference in this Performance Guarantee to the Contract is made for the purpose of convenience and shall not be construed as any intention whatsoever to create an accessory obligation or any intention whatsoever to create a suretyship;
 - 3.2 its obligations under this Performance Guarantee is restricted to the payment of money.
4. Subject to the Guarantor's maximum liability referred to in 1, the Guarantor undertakes to pay to the Employer the Guaranteed Sum or the full outstanding balance upon receipt of a first written demand from the Employer to the Guarantor at the Guarantor's physical address calling up this Performance Guarantee, such demand stating that:
 - 4.1 the Contract has been terminated due to the Contractor's default and that this Performance Guarantee is called up in terms of 4; or
 - 4.2 a provisional or final sequestration or liquidation court order has been granted against the Contractor and that the Performance Guarantee is called up in terms of 4; and
 - 4.3 the aforesaid written demand is accompanied by a copy of the notice of termination and/or the provisional/final sequestration and/or the provisional liquidation court order.
5. It is recorded that the aggregate amount of payments required to be made by the Guarantor in terms of 4 shall not exceed the Guarantor's maximum liability in terms of 1.
6. Payment by the Guarantor in terms of 4 shall be made within seven (7) calendar days upon receipt of the first written demand by the Employer.
7. Payment by the Guarantor in terms of 4 will only be made against the return of the original Performance Guarantee by the Employer.
8. The Employer shall have the absolute right to arrange his affairs with the Contractor in any manner which the Employer may deem fit and the Guarantor shall not have the right to claim his release from this Performance Guarantee on account of any conduct alleged to be prejudicial to the Guarantor.
9. The Guarantor chooses the physical address as stated above for the service of all notices for all purposes in connection herewith.
10. This Performance Guarantee is neither negotiable nor transferable and shall expire in terms of 2, where after no claims will be considered by the Guarantor. The original of this Guarantee shall be returned to the Guarantor after it has expired.
11. This Performance Guarantee, with the required demand notices in terms of 4 shall be regarded as a liquid document for the purposes of obtaining a court order.
12. Where this Performance Guarantee is issued in the Republic of South Africa the Guarantor hereby consents in terms of Section 45 of the Magistrate's Courts Act 32 of 1944, as amended, to the jurisdiction of the Magistrate's Court of any district having jurisdiction in terms of Section 28 of the said Act, notwithstanding that the amount of the claim may exceed the jurisdiction of the Magistrate's Court.

Signed at

Date

Guarantor's signatory (1)

.....
Print Name Capacity

Guarantor's signatory (2)

.....
Print Name Capacity

.....
Witness signatory (1) Print Name

.....
Witness signatory (2) Print Name



CAPRICORN DISTRICT MUNICIPALITY

C1.4 Occupational Health and Safety

AGREEMENT IN TERMS OF THE OCCUPATIONAL HEALTH AND SAFETY ACT, 1993 (ACT NO 85 OF 1993)

THIS AGREEMENT IS made at

on the day of in the year

Between CAPRICORN DISTRICT MUNICIPALITY (hereinafter called "the Employer") of the one part, herein represented by

In his capacity as

and delegate of the Employer in terms of the Employer's standard powers of delegation pursuant to the provisions of Act No 7 of 1998,

and

(hereinafter called "the Mandatory") of the other part, herein represented by

.....

In his capacity as

and being duly authorized by virtue of a resolution appended hereto as Annexure A;

WHEREAS the Employer requires certain works be constructed, viz **NAIRIN VILLAGE WATER SUPPLY** and has accepted a Tender by the Mandatory for the construction, completion and maintenance of such Works and whereas the Employer and the Mandatory have agreed to certain arrangements and procedures to be followed in order to ensure compliance by the Mandatory with the provisions of the Occupational Health and Safety Act, 1993 (Act 85 of 1993).

NOW THEREFORE THIS AGREEMENT WITNESSES AS FOLLOWS:

- 1 The Mandatory shall execute the work in accordance with the Contract Documents pertaining to this Contract.
- 2 This Agreement shall hold good from its Commencement Date, which shall be the date of a written notice from the Employer or engineer requiring him to commence the execution of the Works, to either -
 - (a) the date of the Final Certificate issued in terms of Clause 5.16.1 of the South African Institution of Civil Engineering General Conditions of Contract for construction work, 3RD Edition 2015 (hereinafter referred to as "the GCC"), or
 - (b) The date of termination of the Contract in terms of Clause 09 of the GCC.

- 3 The Mandatory declares himself to be conversant with the following:
- (a) All the requirements, regulations and standards of the Occupational Health and Safety Act (Act 85 of 1993), hereinafter referred to as "The Act", together with its amendments and with special reference to the following Sections of The Act:
 - (i) Section 8 : General duties of Employers to their employees
 - (ii) Section 9 : General duties of Employers and self-employed persons to persons other than employees
 - (iii) Section 37 : Acts or omissions by employees or mandatories
 - (iv) Sub-section 37(2) relating to the purpose and meaning of this Agreement
 - (b) The procedures and safety rules of the Employer as pertaining to the Mandatory and to all his subcontractors.
- 4 In addition to the requirements of the ruling GCC (as amended by Special Condition of Contract section contained in this Contract Documents) and all relevant requirements of the above-mentioned document/s, the Mandatory agrees to execute all the Works forming part of this Contract and to operate and utilize all machinery, Plant and equipment in accordance with the Act.
- 5 The Mandatory is responsible for the compliance with the Act by all his subcontractors, whether or not selected and/or approved by the Employer.
6. The Mandatory warrants that all his and his subcontractors' workmen are covered in terms of the Compensation for Occupational Injuries and Diseases Act, 1993 (Act No 130 of 1993), which cover, shall remain in force whilst any such workmen are present on site. A letter of good standing from the Compensation Commissioner to this effect must be produced to the Employer upon signature of the agreement.
7. The Mandatory undertakes to ensure that he and/or subcontractors and/or their respective employers will at all times comply with the following conditions:
- a) The Mandatory shall assume the responsibility in terms of Section 16.1 of the Act. The Mandatory shall not delegate any duty in terms of Section 16.2 of this Act without the prior written approval of the Employer. If the Mandatory obtains such approval and delegates any duty in terms of section 16.2 a copy of such written delegation shall immediately be forwarded to the Employer.
 - b) All incidents referred to in the Act shall be reported by the Mandatory to the Department of Labour as well as to the Employer. The Employer will further be provided with copies of all written documentation relating to any incident.
 - c) The Employer hereby obtains an interest in the issue of any formal enquiry conducted in terms of section 32 of the Act into any incident involving the Mandatory and/or his employees and/or his subcontractors.

In witness thereof the parties hereto have set their signatures hereon in the presence of the subscribing witnesses:

SIGNED FOR AND ON BEHALF OF THE EMPLOYER :

Witness Witness

(Name) (Name)

(Print) (Print)

SIGNED FOR AND ON BEHALF OF THE MANDATARY :

Witness Witness

(Name) (Name)

(Print) (Print)

ANNEXURE A

CERTIFICATE OF AUTHORITY FOR SIGNATORY TO AGREEMENT IN TERMS OF OCCUPATIONAL HEALTH AND SAFETY ACT, 1993 (ACT NO 85 OF 1993)

The signatory for the company that is the Contractor in terms of the above-mentioned Contract and the Mandatory in terms of the above-mentioned Act shall confirm his or her authority thereto by attaching to this page a duly signed and dated copy of the relevant resolution of the board of directors.

By resolution of the board of directors passed at a meeting held on 200.....,

Mr//Ms whose signature

appears below, has been duly authorised to sign the AGREEMENT IN TERMS OF THE OCCUPATIONAL HEALTH AND SAFETY ACT, 1993 (ACT 85 OF 1993) on behalf of

.....

SIGNED ON BEHALF OF THE COMPANY :

IN HIS/HER CAPACITY AS :

DATE :

SIGNATURE OF SIGNATORY :

WITNESS :..... WITNESS :.....

NAME (in capitals):..... NAME :.....



CAPRICORN DISTRICT MUNICIPALITY

C2.1 Special Conditions Of Contract

The following special conditions of contract, which include amendments to, omissions of or additions to certain clauses of the "General Conditions of Contract for Construction Works, Third Edition (2015)", shall be applicable to the works. In the case of conflict with the mentioned general conditions of contract, these special conditions of contract shall be binding and applicable to the contract.

Each clause with the prefix SCC shall refer to the concurrent clause in the general conditions of contract. Such clause shall substitute, supplement or amend the clause with the same number in the general conditions of contract. Where there is no such concurrent clause in the general conditions of contract the SCC clause shall be numbered as a new clause in the special conditions of contract.

1. DEFINITIONS, INTERPRETATIONS AND GENERAL PROVISIONS

SCC 1.1.1.15 EMPLOYER

Add the following to GCC 1.1.1.15:

The employer is the **Capricorn District Municipality**, and includes any persons appointed by the Employer. The official address is:

**Capricorn District Municipality
41 Biccard Street
P O Box 4100
POLOKWANE
0700**

SCC 1.1.1.16 EMPLOYER'S AGENT

Add the following to GCC 1.1.1.16:

The Engineer means Mont Consulting Engineers, and includes any persons appointed by the Engineer. The official address is:

**SADC PROJECT CONSULTING (PTY) LTD & ORBITALS TRADING AND PROJECTS JV
Stand No 19A, Church Street, , Polokwane, 0700**

**Cell: 071 413 7467
Email: info@orbitals.co.za**

2. AMBIGUITY IN DOCUMENTS

Add the following to GCC 2.4:

2.4.1 The several documents forming the contract shall rank in the following order of precedence:

- a) contract agreement;
- b) tender form and appendix;
- c) special conditions of contract;
- d) project specifications;
- e) general conditions of contract;
- f) drawings;
- g) standardised specifications (SANS 1200) and particular specifications;
- h) schedule of quantities and summary;
- i) statutory regulations and requirements;
- j) standard SANS specifications (not SANS 1200);
- k) Other standard specifications.

If the requirements of any part of the tender document contradict any other part, the document in the highest position on the above order of precedence, shall have preference and apply.

3. PROGRAMME OF THE WORKS

SCC 5.6.1 PROGRAMM

Add the following to GCC 5.6.1

The critical path of the works shall also be stipulated clearly in the programme.

4. INSTRUCTIONS AND DRAWINGS

SCC 5.9.1 DRAWINGS AND INSTRUCTIONS

Add the following to GCC 5.9.1

The Contractor is entitled to three (3) free sets of paper plans for normal use and one (1) free set of paper plans on which to enter "as built" information. He shall also be supplied with one (1) free copy of the contract document. These drawings and contract document shall be issued to the Contractor, at the time of commencement of the contract, by the Engineer.

SCC 5.9.7 ENGINEER TO APPROVE CONTRACTOR'S DESIGNS AND DRAWINGS

Add the following to GCC 5.9.7:

Although the Engineer may approve plans and designs of the Contractor, this does not exempt the Contractor from his responsibility. The professional responsibility for such designs shall be that of the Contractor and his Engineer.

5. CLEARANCE OF SITE

SCC 5.15.1 CLEARANCE OF SITE ON COMPLETION

Add the following to GCC 5.15.1:

After completion of the works, the Contractor shall obtain certificates from all concerned land owners on whose property works have been executed, stating that they are satisfied with the condition of their property, which will normally include finishing of pipe trenches and structures, clearance and finishing of all stone quarries, borrow pits, diversions, private or tertiary or haulage roads that have been used for the transport of material, waste material, fencing, gates, etc on their properties. These certificates shall all be handed to the Engineer before he issues the certificate of completion. Notwithstanding a certificate of completion will not be issued if the work is not to the satisfaction of the Engineer.

6. CONTRACTOR'S EMPLOYEES

SCC 4.10 ENGAGEMENT OF EMPLOYEES

Add the following to clause 4.10.1:

In the event that the Contractor does not pay local labour or any outside agency employed on a monthly basis, the Employer has the automatic right to deduct such wages from the Contractor's next payment certificate. This will be deducted from either monies due to the Contractor or from retention already retained on the project. Payments to the local labour or outside agency will be made by cession.

7. MATERIALS, WORKMANSHIP AND CONSTRUCTIONAL PLANT

SCC 7.1 QUALITY OF PLANT, MATERIALS AND WORKMANSHIP

Add the following to GCC 7.2.1:

No second-hand or reject material shall be used without written permission from the Engineer.

SCC 7.4.4 COST OF TEST SPECIMENS AND TESTS

Substitute GCC 7.4.4 with the following:

- (a) It is deemed that the Contractor has made provision in his tender for all such services and tests that are required from him. It is the duty of the Contractor to, at his own cost and by means of the necessary tests, prove to the Engineer that the works and compaction prescribed, comply with the specification.

8. EXAMINATION OF THE WORKS

SCC 7.5.1 EXAMINATION OF WORK BEFORE COVERING UP

Add the following to GCC 7.5.1:

The Contractor shall give the Engineer a reasonable time to accommodate examinations in his programme, in which case a time for inspection can be agreed upon.

SCC 7.5.3 NOTICE TO BE GIVEN WHEN READY FOR TESTING

Add the following to paragraph 2 of GCC 7.5.3:

If the Engineer attends with the purpose of examining any part or materials of the works at any time and date as agreed upon with the Contractor, and it is found that the works or materials are not yet ready for inspection, the Contractor shall be responsible for the costs of such a visit by the Engineer.

9. INDEMNIFICATIONS

SCC 8.4.2 INDEMNITY BY EMPLOYER

Add the following to GCC 8.4.2:

The Contractor indemnifies the Employer against any liability in respect of damage to or physical loss of the property of any person or injury to or death of any person due to not complying with the Occupational Health and Safety Act No 85 of 1993. Attached in the tender document is the form "Contract between Employer and Contractor" to be completed by the successful Contractor.

SCC 8.6.1 INSURANCES

Add the following to GCC 8.6.1:

The amount shall be per occurrence. The number of occurrences is unlimited.

Add the following to GCC 8.6.6:

Within 14 days of receipt of the letter of acceptance of his tender, the Contractor shall submit proof of payment to the Engineer.

10. VARIATIONS

SCC 6.5 DAYWORK

Add the following to GCC 6.5:

"Total remuneration" shall include the following:

- Basic wage
- Holiday fund stamp
- Unemployment insurance
- Employee's compensation
- Service bonus

Add the following to GCC 6.5.4:

The percentage allowance stated in the appendix shall also include travelling cost or travelling allowance (transport of workmen with the Contractor's transport vehicles or transport vehicles hired by the Contractor or for which the Contractor paid), and residence allowance and other wages that are payable to the workmen on the date for submission of tenders.

11. SUSPENSION OF THE WORKS

SCC 5.11.1 SUSPENSION OF THE WORKS

Add the following to GCC 5.11.1:

No payment shall be made for costs incurred by recompiling a construction programme. In the case of suspension of work, either for a change in sequence or as a result of GCC 5.11.2 to 5.11.3, no payment shall be made for such costs resulting from this.

12. EXTENSION OF TIME FOR COMPLETION

SCC 1.1.1.14 TIME FOR ACHIEVING PRACTICAL COMPLETION

Add the following to GCC 5.12.1:

The time for achieving practical completion shall exclude the period of builder's holidays from 15 December 2022 till January 2023, as well as other special non-working days and public holidays.

SCC 5.12.1 EXTENSION OF TIME FOR COMPLETION

Add the following to GCC 5.12.1:

Extension of the time for completion as a result of extra or additional work and unfavourable physical conditions shall only be granted if such work or conditions influence work on the critical path of the programme. If no definitive method for extension of time due to weather conditions and rain is specified, extension of time as a result of this shall also only be applicable if it influences the critical path of activities.

SCC 5.12.2 SOME REASONS FOR EXTENSIONS OF TIME

Add the following to GCC 5.12.2:

Abnormal Climatic Conditions.

No extension of the time for completion shall be granted on the grounds of normal rainfall conditions, but extension of time in terms of relevant clause of the general conditions of contract on the grounds of abnormal rainfall or wet conditions shall be calculated separately for each calendar month or part thereof, according to the following formula. It shall be calculated as follows for the time for completion, including any extension thereof:

$$V = (N_w - N_n) + \left(\frac{R_w + R_n}{X} \right)$$

- V = Extension of time for calendar days of the calendar month concerned. If the value of V is negative and the absolute value thereof is greater than Nn, V is taken as negative Nn.
- Nw = Actual number of days during calendar month on which a rainfall of Y mm or more is recorded.
- Nn = Average number of days in the calendar month concerned on which a rainfall of Y mm or more is recorded in terms of existing rainfall data.
- Rw = Actual rainfall for the calendar month concerned in mm.
- Rn = Average rainfall for the calendar month in mm deduced from existing rainfall data.

The total extension of time is the algebraic sum of the monthly totals for the period concerned. Extension of time for parts of a month shall be calculated by using pro rata values of Nn and Rn. If the algebraic sum of the monthly totals is negative, no reduction of the time for completion as a result of rainfall shall be applicable.

This formula does not take any delays as a result of flood damage, which may cause further or simultaneous delays; into consideration and flood damage shall be treated separately for purposes of extension of time for completion.

The factor (Nw - Nn) is considered as a fair allowance for deviation from the normal for the number of days on which the rainfall exceeds Y mm. The factor (Rw - Rn)/X is considered as a fair allowance for deviation from the normal for the number of days on which the rainfall does not exceed Y mm, but on which wet conditions will hamper or disrupt work.

For the purpose of this contract the values of Nn, Rn, X and Y will be the relevant values of the nearest weather station to the site as supplied by the South African Weather Buro. It is the sole responsibility of the Tenderer to acquaint himself with the relevant values. These values shall, at the start of the contract be submitted to the Engineer for scrutiny and approval.

SCC 5.12.2.3 AVAILABILITY OF PETROLEUM PRODUCTS

The tender shall be based on the available supply of petroleum products required for the completion of the works. If, during the contract period, for reasons outside the control of the Contractor, a restriction or breakdown in the supply of petroleum products may occur, which has an actual influence on the execution of the works for a period of at least thirty (30) days, the Contractor shall make all reasonable efforts to complete the works and he shall be entitled to an extension of the time for completion and he shall also be entitled to such an adjustment of the contract price as deemed reasonable by the Engineer, with consideration of all materials and relevant factors directly responsible or having a direct effect on such restriction or breakdown, with the inclusion of the Contractor's site and overhead costs relevant to the contract.

SCC 5.12.2.3 EXTENSION OF TIME DUE TO SHORTAGE OF MATERIAL

If, during the preparation of his tender or during construction, the Contractor bases his unit prices on prices obtained from specific material or specific suppliers, it will be accepted that the Contractor has ascertained that such material shall be available on a continuous basis for the execution of the contract.

No extension of time shall be granted if material cannot be obtained locally, but is available from other sources in the country, and no additional remuneration shall be granted for increased costs due to obtaining material from sources in other parts of the country.

If suppliers cannot adhere to the quoted delivery dates, any delays resulting from this shall be considered as a matter between the supplier and the Contractor. Extension of time could be granted under such conditions after complete proofs have been submitted to and accepted by the Engineer, but without any financial implications for the Employer.

13. INTERIM PAYMENTS

SCC 6.10.2 VALUATION OF MATERIAL BROUGHT ONTO SITE

Add the following to GCC 6.10.2:

Material or goods for which payment is made in terms of this clause, shall be identified uniquely and be stored in a space approved by the Engineer, and which will only be used for the purposes of the Employer.

SCC 6.10.3 RETENTION MONEY

Add the following to GCC 6.10.3:

No limit of retention money will be applicable only the 10% as stated in the Contract Data will be applicable on the contract.

SCC 6.10.5 EMPLOYER'S OBLIGATION TO PAY

Replace GCC 6.10.5 with the following:

The Engineer shall deliver to the Employer the Contractor the payment certificate referred to in clause 6.10.3 within 07 (seven) days after the receipt by the Engineer of the Contractor's said statement, and the Employer shall pay the amount due to the Contractor within 65 (sixty five) days after receipt by the Employer of the payment certificate signed by the Engineer.

SCC 6.10.1 VALUE ADDED TAX

Add the following to GCC 6.10.1:

Value added tax (VAT) shall be calculated on each payment certificate, but it shall remain the responsibility of the Contractor to issue a tax invoice for the certified amount. The Contractor is responsible for the payment of VAT.

14. DEFECTS

SCC 7.8.1 MAKING GOOD OF DEFECTS

Add the following to GCC 7.8.1:

If it is deemed necessary in the opinion of the Engineer, the defects liability period after repairs can be extended for a further period of twelve months or for a period to the discretion of the Engineer, as regards the relevant part of the works that is made good.

15. LEGAL PROVISIONS

SCC 4.3.1 COMPLIANCE WITH APPLICABLE LAWS

The Contractor shall be conversant with all the requirements, regulations, and standards of the Occupational Health and Safety Act, 1993 (Act No. 85 of 1993), hereinafter referred to as "the Act" and undertakes to execute all the works forming part of this Contract and to operate and utilise all machinery, plant, and equipment in accordance with the Act.

The Contractor shall, from the commencement date of the Contract up to completion or termination thereof, be the Employer's mandatory regarding occupational health and safety for all activities on the site but without derogating from his status in his own right as an employer or a user in accordance with the Act.

The Contractor is responsible for the compliance with the Act by all his subcontractors, whether or not nominated and/or approved by the Employer.

The Contractor shall, when called upon to do so, enter into and execute an Agreement, as provided for under Section 37(2) of the Act, with the Employer. The Agreement in the relevant form shall be prepared at the expense of the Employer.

16. LATENT DEFECT PERIOD

SCC 5.16.3 LATENT DEFECT PERIOD

The latent defect period is 10 years.

17. ADJUDICATION

SCC 10.5.3 ADJUDICATION BOARD MEMBERS

The number of Adjudication Board Members to be appointed is three.



CAPRICORN DISTRICT MUNICIPALITY

C3. Schedule of Quantities

C3.1 Preamble to Schedule of Quantities

1. The general conditions of contract, the special conditions of contract (if any), the specifications (including the project specification) and the drawings are to be read in conjunction with the schedule of quantities.
2.
 - a) The schedule comprises items covering the Contractor's profit and costs of general liabilities and of the construction of temporary and permanent works.
 - b) The Contractor is at liberty to insert a rate of his own choosing for each item in the schedule and his attention is drawn to the fact that the Contractor has the right, under various circumstances, to payment for additional works carried out and that the Engineer is obliged to base his assessment of the rates to be paid for such additional work on the rates inserted in the schedule by the Contractor.
 - c) Clause 8 of each standardised specification and the measurement and payment clause of each particular specification, read together with the relevant clauses of the project specification, set out what ancillary or associated activities are included in the rates for the operations specified.
3. Descriptions in the schedule of quantities are abbreviated and the schedule has been drawn up generally in accordance with the latest issue of Civil Engineering Quantities¹. Should any requirement of the measurement and payment clause of the applicable standardised specification², or the project specification², or the particular specification(s)² conflict with the terms of the schedule or, when relevant, Civil Engineering Quantities¹, the requirement of the standardised, project or particular specification, as applicable, shall prevail.
4. Unless otherwise stated, items are measured net in accordance with the drawings, and no allowance has been made for waste.
5. The prices and rates to be inserted in the schedule of quantities are to be the full inclusive prices to the Employer for the work described under the several items, value added tax excluded. Such prices shall cover all costs and expenses that may be required in and for the construction of the work described, and shall cover the cost of all general risks, liabilities and obligations set forth or implied in the documents on which the quotation is based.
6. A price or rate is to be entered against each item in the schedule of quantities, whether the quantities are stated or not. An item against which no price is entered will be considered to be covered by the other prices or rates in the schedule.
7. The Contractor must price each item in the schedule of quantities in **BLACK INK**.
8. **All prices and rates shall exclude value added tax (VAT)**. The Contractor shall calculate value added tax and enter it at the end of the summary of the schedule of quantities.
9. For the purposes of this Schedule of Quantities, the following words shall have the meanings hereby assigned to them:

Unit	:	The unit of measurement for each item of work as defined in the Specifications.
Quantity	:	The number of units of work for each item
Rate	:	The payment per unit of measurement at which the Tenderer tenders to do the work.
Amount	:	The product of the quantity and the rate tendered for an item
Sum	:	An amount tendered for an item, the extent of which is described in the Schedule of Quantities, the specifications or elsewhere but the quantity of work of which is not measured in any units.
Prime Cost (or PC item)	:	A sum fixed by the Engineer and entered in the Schedule of Quantities as the net sum provided to cover the cost of specific goods or materials to be supplied under

the contract, or the net sum to be paid by the Contractor to merchants or others for such articles or materials.¹

- Provisional Sum : A sum of money fixed by the Engineer and entered in the Schedule of Quantities to provide for work not defined at the tender stage and includes any allowance specifically made for unforeseen contingencies.¹
- Extra Over (or EO) : Qualifies an operation (or combination of operations) which is common in a varying degree to a number of other operations and which is scheduled once as “extra over” those other operations in order to avoid a multiplicity of items each reflecting the degree to which the common operations applies. The term “extra over” invariably denoted double measurement, no deduction being made from one on account of the other.¹

10. The units of measurements indicated in the Schedule of Quantities are metric units.

The following abbreviations are used in the Schedule of Quantities:

mm	=	millimetre
m	=	metre
km	=	kilometre
km-pass	=	kilometre-pass
m ²	=	square metre
m ² -pass	=	square metre-pass
ha	=	hectare
m ³	=	cubic metre
m ³ -km	=	cubic metre-kilometre
l	=	litre
kl	=	kilolitre
kg	=	kilogram
t	=	ton (1 000 kg)
no	=	number
%	=	percentage
kW	=	kilowatt
PC Sum	=	prime cost sum
Prov. Sum	=	provisional sum
kPa	=	kilopascal
R/only	=	Rate only
W/day	=	Work day

- 1) The standard system of measurement of Civil Engineering Quantities of South Africa published by the South African Institution of Civil Engineers.
 - 2) See definition in sub clause 2.1 of Part 1 of SANS 0120: Format and Contents.
- 11 Those parts of the contract to be constructed using labour-intensive methods have been marked in the bill of quantities with the letters LI in a separate column or as a prefix or suffix against every item so designated. The works, or parts of the works so designated are to be constructed using labour-intensive methods only. The use of plant to provide such works, other than plant specifically provided for in the scope of works, is a deviation from the contract. The items marked with the letters ‘LI’ are not necessarily an exhaustive list of all the activities which must be done by hand, and this clause does not over-ride any of the requirements in the generic labour intensive specification in the Scope of Works.
 - 12 Where minimum labour intensity is specified by the design the contractor is expected to use their initiative to identify additional activities that can be done labour-intensively in order to comply with the set minimum labour intensity target.
 - 13 Payment for items which are designated to be constructed labour-intensively (either in this schedule or in the scope of works) will not be made unless they are constructed using labour-intensive methods. Any unauthorised use of plant to carry out work, which was to be done labour-intensively will not be condoned, and any works so constructed will not be certified for payment.

DAY WORK LIST

GENERAL

Contractors must complete this list, which will be used to assess the value of work that the Engineer instructs in writing to be done on a day work basis, all in agreement with clause 37.2 of the General Conditions of Contract for Construction Works, Third Edition, 2015 and coupled Special Conditions of Contract. All the rates are fixed and shall be binding till the issuing of the final certificate, except for statutory increases that are announced from time to time.

LABOUR COSTS

Rates for labour as listed below shall include all the allowances as specified in the General Conditions of Contract for Construction Works, Third Edition, 2015 and Special Conditions of Contract. The extra allowance, applicable on Labour costs listed below, is given in the tender appendix and must not be taken into account in this list.

Overtime costs incurred by this contract shall be paid in the same proportion as the amounts actually paid to the employees.

DESCRIPTION	UNIT	RATE
Unschoolled labour	Hour	R
Half- Schooled labour	Hour	R
Pipe layer	Hour	R
Ganger	Hour	R
Foreman / Section leader	Hour	R
Brick layer	Hour	R
Plumber	Hour	R

EQUIPMENT COSTS

Full comprehensive hourly rates, which also include the cost of operators, must be listed below. Rates must also include all the costs of consumable items, maintenance, depreciation, tools, and all other coincidences that shall be necessary to operate the equipment for the purpose it is designed for. The rates must also include all the overhead costs, profits, site supervision, insurance, holidays with payment, travelling costs (or travelling allowances) and residence allowances of operators and any other allowances that are applicable on equipment. The Tenderer must list under each heading the make and specification of the equipment available.

DESCRIPTION	UNIT	RATE
1. Excavators	Hour Hour Hour
2. Front-end loaders	Hour Hour Hour Hour
3. Trucks (m ³ specified)	Hour Hour Hour Hour
4. Water truck (litres specified)	Hour Hour Hour Hour
5. Tractor & Trailer	Hour Hour Hour
6. Compressor	Hour Hour Hour Hour

DESCRIPTION	UNIT	RATE
7. Concrete mixer (litres specified)	Hour Hour Hour Hour
8. "Dumper"(m ³ specified)	Hour Hour Hour Hour
9. Water pumps 75mm..... 100mm..... 150mm.....	Hour Hour Hour
10. Compactors Plate	Hour Hour Hour Hour
11. Other equipment	Hour Hour Hour Hour

CAPRICORN DISTRICT MUNICIPALITY - LIMPOPO PROVINCE

SCHEDULE OF QUANTITIES:

NAIRIN VILLAGE WATER SUPPLY

CONTRACT NO:INF-W02/2022/2023

SCHEDULE A: PRELIMINARY AND GENERAL OBLIGATIONS

SECTION 1: PRELIMINARY AND GENERAL - FIXED CHARGE AND VALUE RELATED OBLIGATIONS

ITEM NUMBER	PAYMENT CLAUSE	DESCRIPTION	UNIT	QUANTITY	RATE	AMOUNT
A.1		FIXED CHARGE AND VALUE RELATED ITEMS: <i>(As specified in SABS 1200 A, SABS 1200 AB and the Project Specifications.)</i>				
1.1		Contractual Requirements:				
1.1.1	8.3.1	Fixed charge contractual requirements.	Sum	1.00		
1.1.2	8.3.1	Value related contractual requirements.	Sum	1.00		
1.2		Facilities for Engineer:				
1.2.1	8.3.2.1 a	Furnished office - 1 No.	Sum	1.00		
1.2.2	8.3.2.1 c	Name board	Sum	2.00		
1.2.3	PSA 14.1 a	Provision of survey equipment.	Sum	1.00		
1.3		Facilities for Contractor:				
1.3.1	8.3.2.2 a	Offices and storage sheds	Sum	1.00		
1.3.2	8.3.2.2 b	Workshops	Sum	1.00		
1.3.3	8.3.2.2 c	Laboratories	Sum	1.00		
1.3.4	8.3.2.2 d	Living accommodation	Sum	1.00		
1.3.5	8.3.2.2 e	Ablution and latrine facilities	Sum	1.00		
1.3.6	8.3.2.2 f	Tools and equipment	Sum	1.00		
1.3.7	8.3.2.2 g	Water supplies, electric power and communications	Sum	1.00		
1.3.8	8.3.2.2 h	Dealing with water	Sum	1.00		
1.3.9	8.3.2.2 i	Access	Sum	1.00		
1.3.10	8.3.2.2 j	Plant	Sum	1.00		
1.3.11	PSA 14.2 a	Materials on site storage and protection.	Sum	1.00		
1.3.12	PSA 14.2 b	Accommodation of traffic.	Sum	1.00		
1.3.13	PSA 14.2 c	Labour intensive activity training.	Sum	1.00		
1.4	8.3.3	Other Fixed Charge Obligations:	Sum	1.00		
1.5	8.3.4	Removal of Site Establishment:	Sum	1.00		
1.6	PSA 14.3 a	Environmental Management:	Sum	1.00		
TOTAL SCHEDULE A - SECTION 1 CARRIED TO SUMMARY:						-

CAPRICORN DISTRICT MUNICIPALITY - LIMPOPO PROVINCE

SCHEDULE OF QUANTITIES:

NAIRIN VILLAGE WATER SUPPLY

CONTRACT NO:INF-W02/2022/2023

SCHEDULE A: PRELIMINARY AND GENERAL OBLIGATIONS

SECTION 2: PRELIMINARY AND GENERAL - TIME RELATED OBLIGATIONS

ITEM NUMBER	PAYMENT CLAUSE	DESCRIPTION	UNIT	QUANTITY	RATE	AMOUNT
A.2		TIME RELATED ITEMS: <i>(As specified in SABS 1200 A, SABS 1200 AB and the Project Specifications.)</i>				
2.1		Contractual Requirements:				
2.1.1	8.4.1	Time related contractual requirements.	Month	12.00		
2.2		Facilities for Engineer:				
2.2.1	8.4.2.1 a	Furnished office - 1 No.	Month	12.00		
2.2.2	8.4.2.1 c	Name boards - 2 No.	Month	12.00		
2.2.3	8.4.2.1 d	Survey assistants and material.	Month	12.00		
2.3		Facilities for Contractor:				
2.3.1	8.4.2.2 a	Offices and storage sheds.	Month	12.00		
2.3.2	8.4.2.2 b	Workshops.	Month	12.00		
2.3.3	8.4.2.2 c	Laboratories.	Month	12.00		
2.3.4	8.4.2.2 d	Living accommodation.	Month	12.00		
2.3.5	8.4.2.2 e	Ablution and latrine facilities.	Month	12.00		
2.3.6	8.4.2.2 f	Tools and equipment.	Month	12.00		
2.3.7	8.4.2.2 g	Water supplies, electric power and communications.	Month	12.00		
2.3.8	8.4.2.2 h	Dealing with water.	Month	12.00		
2.3.9	8.4.2.2 i	Access.	Month	12.00		
2.3.10	8.4.2.2 j	Plant.	Month	12.00		
2.4	8.4.3	Supervision for Duration of the Contract:	Month	12.00		
2.5	8.4.4	Overhead Costs for the Duration of the Contract:	Month	12.00		
2.6	8.4.5	Other Time Related Obligations:	Month	12.00		
2.7	PSA 14.3 b	Environmental Management:	Month	12.00		
2.8	PSA 14.4 a	Construction Management Administration:	Month	12.00		
TOTAL SCHEDULE A - SECTION 2 CARRIED TO SUMMARY:						

CAPRICORN DISTRICT MUNICIPALITY - LIMPOPO PROVINCE

SCHEDULE OF QUANTITIES:

NAIRIN VILLAGE WATER SUPPLY

CONTRACT NO:INF-W02/2022/2023

SCHEDULE A: PRELIMINARY AND GENERAL OBLIGATIONS

SECTION 3: PRELIMINARY AND GENERAL - PROVISIONAL SUMS

ITEM NUMBER	PAYMENT CLAUSE	DESCRIPTION	UNIT	QUANTITY	RATE	AMOUNT
A.3		PROVISIONAL SUMS: <i>(As specified in SABS 1200 A and the Project Specifications.)</i>				
3.1	8.5 b	Community Liaison Officer:				
3.1.1	PSA 14.5 a	Provision for the employment of CLO.	Prov. Sum	12.00	R 7,000.00	R 84,000.00
3.1.2	PSA 14.5 b	Overheads, charges and profit on item 3.1.1.	%	84,000.00		
3.2	8.5 b	PSC Attendance at Site Meeting:				
3.2.1	PSA 14.5 c	Provision for the attendance of PSC members.	Prov. Sum	1.00	R 24,000.00	R 24,000.00
3.2.2	PSA 14.5 d	Overheads, charges and profit on item 3.2.1.	%	24,000.00		
3.3	8.5 b	Basic Skills and Construction Training:				
3.3.1	PSA 14.5 e	Provision for basic skills and construction site safety training.	Prov. Sum	1.00	R 120,000.00	R 120,000.00
3.3.2	PSA 14.5 f	Overheads, charges and profit on item 3.3.1.	%	120,000.00		
3.4	8.5 b	Relocation/Protection of Existing Services:				
3.4.1	PSA 14.5 g	Provision for relocation/protection of existing services.	Prov. Sum	1.00	R 50,000.00	R 50,000.00
3.4.2	PSA 14.5 h	Overheads, charges and profit on item 3.4.1.	%	50,000.00		
3.5	8.5 b	Additional Tests required by Engineer:				
3.5.1	PSA 14.5 i	Provision for additional tests.	Prov. Sum	1.00	R 50,000.00	R 50,000.00
3.5.2	PSA 14.5 j	Overheads, charges and profit on item 3.5.1.	%	50,000.00		
3.6	8.5 b	Occupational Health and Safety Audits:				
3.6.1	PSA 14.5 k	Provision for Occupational Health and Safety audits on site.	Prov. Sum	1.00	R 105,000.00	R 105,000.00
3.6.2	PSA 14.5 l	Overheads, charges and profit on item 3.6.1.	%	105,000.00		
3.6	8.5 b	Socail Facilitation				
3.6.1	PSA 14.5 k	Provision for Social Facilitation by a Client Appointed Service Provider .	Prov. Sum	1.00	R 175,000.00	R 175,000.00
3.6.2	PSA 14.5 l	Overheads, charges and profit on item 3.6.1.	%	175,000.00		
TOTAL SCHEDULE A - SECTION 3 CARRIED TO SUMMARY:						-

CAPRICORN DISTRICT MUNICIPALITY - LIMPOPO PROVINCE

SCHEDULE OF QUANTITIES:

NAIRIN VILLAGE WATER SUPPLY

CONTRACT NO:INF-W02/2022/2023

SCHEDULE A: PRELIMINARY AND GENERAL OBLIGATIONS

SECTION 4: PRELIMINARY AND GENERAL - PRIME COST SUMS

ITEM NUMBER	PAYMENT CLAUSE	DESCRIPTION	UNIT	QUANTITY	RATE	AMOUNT
A.4		PRIME COST ITEMS: <i>(As specified in SABS 1200 A and the Project Specifications.)</i>				
4.1	8.6	Pipe Specials:				
4.1.1	PSA 14.6 k	Provision of pipe specials, valves and fittings for reservoir connections.	PC Sum	1.00	100,000.00	100,000.00
4.1.2	PSA 14.6 l	Overheads, charges and profit on item 4.1.1.	%	100,000.00		
TOTAL SCHEDULE A - SECTION 4 CARRIED TO SUMMARY:						-

CAPRICORN DISTRICT MUNICIPALITY - LIMPOPO PROVINCE

ORB.NAIR.2021

SCHEDULE OF QUANTITIES:

NAIRIN VILLAGE WATER SUPPLY

CONTRACT NO:INF-W02/2022/2023

SCHEDULE A: PRELIMINARY AND GENERAL OBLIGATIONS

SECTION 5: PRELIMINARY AND GENERAL - DAYWORKS

ITEM NUMBER	PAYMENT CLAUSE	DESCRIPTION	UNIT	QUANTITY	RATE	AMOUNT
A.5		DAYWORK: <i>(As specified in SABS 1200 A and the Project Specifications.)</i>				
5.1	8.7	Labour - Normal Working Hours: [Provisional]				
5.1.1		Skilled Labour (Artisan).	hr			Rate Only
5.1.2		Semi-skilled Labour.	hr			Rate Only
5.1.3		Unskilled Labour.	hr			Rate Only
5.1.4		Foreman.	hr			Rate Only
5.1.5		Extra-over rate for items 5.1.1 to 5.1.4 for work during non working hours.	%			Rate Only
5.2	8.7	Materials: [Provisional]				
5.2.1		Allowance for Materials used under Dayworks.	Sum	1.00	R 100,000.00	R 100,000.00
5.2.2		Overheads, Handling and all Charges on Item 5.2.1.	%	100,000.00	10.00%	
5.3	8.7	Plant - Heavy Equipment: [Provisional] <i>(Plant shall not be more than 3 years old or have more than 3000 hrs logged. Operator to be qualified and competency certified.)</i>				
5.3.1		Excavator - Size Cat 225.	hr			Rate Only
5.3.2		Excavator - TLB.	hr			Rate Only
5.3.3		Grader 140G or similar.	hr			Rate Only
5.3.4		Front end loader - bucket capacity $\leq 1.5 \text{ m}^3$.	hr			Rate Only
5.3.5		Front end loader - bucket capacity $>1.5 \text{ m}^3$.	hr			Rate Only
5.3.6		Tip truck - 5 m^3 capacity.	hr			Rate Only
5.3.7		Tip truck - 10 m^3 capacity.	hr			Rate Only
5.3.8		Vibratory compaction roller - 13.5 ton.	hr			Rate Only
5.3.9		Transport cost per any unit of plant to deliver to site and remove from site for items 5.3.1 to 5.3.8	Sum			Rate Only
5.4	8.7	Plant - Small Equipment: [Provisional]				
5.4.1		Pedestrian roller - BW90 or similar.	hr			Rate Only
5.4.2		Vibratory plate compactor.	hr			Rate Only
5.4.3		Vibratory rammer.	hr			Rate Only
5.4.4		Transport cost per any unit of plant to deliver to site and remove from site for items 5.4.1 to 5.4.3.	Sum			Rate Only
TOTAL SCHEDULE A - SECTION 5 CARRIED TO SUMMARY:						-

CAPRICORN DISTRICT MUNICIPALITY - LIMPOPO PROVINCE

ORB.NAIR.2021

SCHEDULE OF QUANTITIES:

NAIRIN VILLAGE WATER SUPPLY

CONTRACT NO:INF-W02/2022/2023

SCHEDULE A: PRELIMINARY AND GENERAL OBLIGATIONS

SECTION 6: PRELIMINARY AND GENERAL - TEMPORARY WORKS

ITEM NUMBER	PAYMENT CLAUSE	DESCRIPTION	UNIT	QUANTITY	RATE	AMOUNT
A.6		TEMPORARY WORKS: <i>(As specified in SABS 1200 A and the Project Specifications.)</i>				
6.1	8.8	Access Roads to the Works.				
6.1.1	PSA 14.7 a	Provision and maintenance of construction access to sites, camp or pipeline routes as required by the contractor.	Sum	1.00		-
6.2	8.8	Safety Measures at Excavations:				
6.2.1	PSA 14.7 b	Provision of all safety measures required to fully protect all excavations against public access, injury or any other possible accident.	Sum	1.00		-
TOTAL SCHEDULE A - SECTION 6 CARRIED TO SUMMARY:						-

CAPRICORN DISTRICT MUNICIPALITY - LIMPOPO PROVINCE

ORB.NAIR.2021

SCHEDULE OF QUANTITIES:

NAIRIN VILLAGE WATER SUPPLY

CONTRACT NO:INF-W02/2022/2023

SCHEDULE B: BULK SUPPLY AND NETWORK DISTRIBUTION WORKS

SECTION 1: EARTHWORKS FOR PIPE TRENCHES

ITEM NUMBER	LI	PAYMENT CLAUSE	DESCRIPTION	UNIT	QUANTITY	RATE	AMOUNT
B.1			EARTHWORKS: <i>(As specified in SABS 1200 DB and the Project Specifications.)</i>				
1.1			Site Clearance:				
1.1.1	LI	8.3.1 a	Clear vegetation, 800 mm wide. (Provisional)	m	43,500.00		
1.1.2		8.3.1 b	Clear trees of girth over 1.0 m.	No.	17.00		
1.1.3		8.3.1 c	Remove 150 mm topsoil, 800 mm wide.	m ²	5,220.00		
1.1.4	LI		Demolish existing concrete.	m ³	9.00		
1.2		PSDB 1.1	Excavation using Plant:				
1.2.1			Excavate in all materials for trench depths up to 1000 mm, 800 mm wide.	m	43,500.00		
1.2.2			Excavate in all materials for trench depths exceeding 1000 mm up to 1500 mm, 800 mm wide.	m	2,175.00		
1.2.3			Extra-over items 1.2.1 and 1.2.2 for excavation in intermediate material.	m ³	1,087.50		
1.2.4			Extra-over items 1.2.1 and 1.2.2 for excavation in hard material. (Provisional)	m ³	8,700.00		
1.2.5			Excavate and dispose of unsuitable material from trench bottom.	m ³	2,610.00		
1.2.6			Spoil unsuitable backfill material.	m ³	522.00		
1.3	LI	PSDB 1.1	Excavation using Labour Intensive Methods:				
1.3.1	LI		Extra-over Item 1.2.1 for excavation in soft material using labour intensive methods.	m	43,500.00		
1.3.2	LI		Extra-over Item 1.2.2 for excavation in soft material using labour intensive methods.	m	2,175.00		
1.3.4	LI		Extra-over Item 1.2.3 for excavation in intermediate material using labour intensive methods.	m ³	1,087.50		
1.3.5	LI		Extra-over Item 1.2.5 for excavate and dispose of unsuitable material using labour intensive methods.	m ³	2,610.00		
SUB-TOTAL SCHEDULE B - SECTION 1 CARRIED FORWARD:							

CAPRICORN DISTRICT MUNICIPALITY - LIMPOPO PROVINCE

ORB.NAIR.2021

SCHEDULE OF QUANTITIES:

NAIRIN VILLAGE WATER SUPPLY

CONTRACT NO:INF-W02/2022/2023

SCHEDULE B: BULK SUPPLY AND NETWORK DISTRIBUTION WORKS

SECTION 1: EARTHWORKS FOR PIPE TRENCHES

ITEM NUMBER	LI	PAYMENT CLAUSE	DESCRIPTION	UNIT	QUANTITY	RATE	AMOUNT
SUB-TOTAL SCHEDULE B - SECTION 1 BROUGHT FORWARD:							-
B.1			EARTHWORKS: (Continues) <i>(As specified in SABS 1200 DB and the Project Specifications.)</i>				
1.4		PSDB 1.2	Backfill and Compaction:				
1.4.1	LI		Backfill and compact trenches using labour intensive methods.	m ³	31,059.00		
1.4.2			Backfill road crossings using a commercial type G4 material compacted to 98% Mod. AASHTO density.	m ³	1,644.30		
1.5			Excavation Ancillaries;				
1.5.1		8.3.3.1 a	Make up deficiency in backfill material from other excavations.	m ³	1,467.54		
1.5.2		8.3.3.1 b	Make up deficiency in backfill material from borrow pits. Free-haul is 5.0 km.	m ³	815.30		
1.5.4		8.3.3.2	Opening and closing designated borrow pits.	Sum	1.00		
1.5.5		8.3.3.3	Compaction within road reserve to 90 % of Modified AASHTO density clause 5.7.1.	m ³	1,644.30		
1.5.6		8.3.3.3	Compaction within road reserve to 98 % of Modified AASHTO density, as per clause 5.7.2.	m ³	986.58		
1.6			Overhaul:				
1.6.1		8.3.3.4	Overhaul in excess of the free-haul of 5.0 km.	m ³ -km	815.00		
1.7			Existing Services:				
1.7.1		8.3.5 a	Services that intersect a trench.	No.	17.00		
1.8			Finishing:				
1.8.1		8.3.6.1 c	Reinstate road surfaces using 40 mm asphalt.	m ²			
1.8.2	LI		Topsoil trenches. (Provisional)	m ²	5,481.00		
TOTAL SCHEDULE B - SECTION 1 CARRIED TO SUMMARY:							-

CAPRICORN DISTRICT MUNICIPALITY - LIMPOPO PROVINCE

ORB.NAIR.2021

SCHEDULE OF QUANTITIES:

NAIRIN VILLAGE WATER SUPPLY

CONTRACT NO:INF-W02/2022/2023

SCHEDULE B: BULK SUPPLY AND NETWORK DISTRIBUTION WORKS

SECTION 2: PIPE BEDDING

ITEM NUMBER	LI	PAYMENT CLAUSE	DESCRIPTION	UNIT	QUANTITY	RATE	AMOUNT
B.2			BEDDING: <i>(As specified in SABS 1200 LB and the Project Specifications.)</i>				
2.1		8.2.1	Bedding from Trench Excavations: <i>(Bedding to be Class C for flexible pipes as indicated in the contract drawings)</i>				
2.1.1	LI		Provision of bedding from pipe trench excavation within 1.0 km, using selected granular material.	m ³	10,440.00		
2.1.2	LI		Provision of bedding from pipe trench excavation within 1.0 km, using selected fill material.	m ³	3,654.00		
2.2		8.2.2	Imported Bedding Material: <i>(Bedding to be Class C for flexible pipes as indicated in the contract drawings)</i>				
2.2.1			Provision of bedding imported from designated borrow pit using selected granular material.	m ³	2,610.00		
2.2.2			Provision of bedding imported from designated borrow pit using selected fill material.	m ³	914.00		
TOTAL SCHEDULE B - SECTION 2 CARRIED TO SUMMARY:							

CAPRICORN DISTRICT MUNICIPALITY - LIMPOPO PROVINCE

ORB.NAIR.2021

SCHEDULE OF QUANTITIES:

NAIRIN VILLAGE WATER SUPPLY

CONTRACT NO:INF-W02/2022/2023

SCHEDULE B: BULK SUPPLY AND NETWORK DISTRIBUTION WORKS

SECTION 3: MEDIUM PRESSURE PIPELINES AND ANCILLARIES

ITEM NUMBER	LI	PAYMENT CLAUSE	DESCRIPTION	UNIT	QUANTITY	RATE	AMOUNT
B.3			MEDIUM PRESSURE PIPES: <i>(As specified in SABS 1200 L, SABS 1200 GA and the Project Specifications.)</i>				
3.1	LI	8.2.1	Supply, Lay and Bed uPVC Pipes Complete: <i>(The rates shall include disinfecting of pipes after completion of hydraulic pipe test.)</i>				
3.1.1	LI		75 mm uPVC medium pressure pipes - Class 9.	m	29,500.00		
3.1.2	LI		160 mm uPVC medium pressure pipes - Class 12	m	2,500.00		
3.1.3	LI		160 mm uPVC medium pressure pipes - Class 9.	m	5,000.00		
3.1.4	LI		25 mm HDPE PN 20	m	6,500.00		
3.2	LI	8.2.2	Fittings and Specials - uPVC Lyng Bends: <i>(Extra-over rate to Items 3.1)</i>				
3.2.1			75 mm Upvc class 16:				
3.2.1.1	LI		uPVC bends less than 25 degree angle.	No.	150.00		
3.2.1.2	LI		uPVC bends with 45 degree angle.	No.	30.00		
3.2.1.3	LI		uPVC bends with 90 degree angle.	No.	30.00		
3.2.2			160 mm uPVC class 16:				
3.2.2.1	LI		uPVC bends less than 25 degree angle.	No.	15.00		
3.2.2.2	LI		uPVC bends with 45 degree angle.	No.	20.00		
3.2.2.3	LI		uPVC bends with 90 degree angle.	No.	20.00		
3.2.3	LI		200 mm uPVC class 16:				
3.2.3.1			uPVC bends less than 25 degree angle.	No	1.00		Rate Only
3.2.3.2			uPVC bends with 45 degree angle.	No	1.00		Rate Only
3.2.3.3			uPVC bends with 90 degree angle.	No	1.00		Rate Only
3.3	LI	8.2.2	Specials and Fittings - Cast Iron Equal Tees: <i>(Bitumen dipped and LYNG sockets on all sides all to SABS 546 and SABS 966.)</i>				
3.3.1	LI		75 mm dia.	No.	25.00		
3.3.2	LI		160 mm dia.	No.	10.00		
3.3.3	LI		200 mm dia	No.	0.00		
SUB-TOTAL SCHEDULE B - SECTION 3 CARRIED FORWARD:							

CAPRICORN DISTRICT MUNICIPALITY - LIMPOPO PROVINCE

ORB.NAIR.2021

SCHEDULE OF QUANTITIES:

NAIRIN VILLAGE WATER SUPPLY

CONTRACT NO:INF-W02/2022/2023

SCHEDULE B: BULK SUPPLY AND NETWORK DISTRIBUTION WORKS

SECTION 3: MEDIUM PRESSURE PIPELINES AND ANCILLARIES

ITEM NUMBER	LI	PAYMENT CLAUSE	DESCRIPTION	UNIT	QUANTITY	RATE	AMOUNT
SUB-TOTAL SCHEDULE B - SECTION 3 BROUGHT FORWARD:							-
B.3			MEDIUM PRESSURE PIPES: <i>(As specified in SABS 1200 L, SABS 1200 GA and the Project Specifications.)</i>				
3.4	LI	8.2.2	Specials and Fittings - Hydrant Tees: <i>(Cast iron hydrant tees, Bitumen dipped and LYNG sockets to SABS 546 and SABS 966 with flanged branch, 80 mm dia, drilled to SABS 1123, Table 16.)</i>				
3.4.1	LI		75 mm dia.	No.	5.00		
3.4.2	LI		160 mm dia.	No.	3.00		
3.4.3							
3.5	LI	8.2.2	Specials and Fittings - Cast Iron Scour Tees: <i>(Cast iron scour tee, Bitumen dipped and LYNG sockets to SABS 546 and SABS 966 with flanged branch, 100 mm dia, drilled to SABS 1123, Table 16.)</i>				
3.5.1	LI		75 mm dia.	No.	5.00		
3.5.2	LI		160 mm dia.	No.	5.00		
3.5.3							
3.6	LI	8.2.2	Specials and Fittings - Cast Iron End Caps:				
3.6.1	LI		75 mm dia.	No.	20.00		
3.6.2	LI		160 mm dia.	No.	10.00		
3.7		8.2.2	Specials and Fittings - Cast Iron Reducers: <i>(Bitumen dipped, spigot and socket and socketed cast iron reducers all to SABS 546 and SABS 966.)</i>				
3.7.1	LI		75 mm x 160 mm dia. [S]	No.	30.00		
3.7.2	LI		75 mm x 200 mm dia. [S]	No.	1.00		Rate Only
3.7.3	LI		160 mm x 200 mm dia. [S]	No.	0.00		
3.8	LI	8.2.2	Specials and Fittings - Flang Adaptors: <i>(Bitumen dipped and LYNG sockets to SABS 546 and SABS 966 with flange drilled to SABS 1123, Table 16.)</i>				
3.8.1	LI		75 mm dia.	No.	20.00		
3.8.2	LI		160 mm dia.	No.	5.00		
SUB-TOTAL SCHEDULE B - SECTION 3 CARRIED FORWARD:							

CAPRICORN DISTRICT MUNICIPALITY - LIMPOPO PROVINCE

ORB.NAIR.2021

SCHEDULE OF QUANTITIES:

NAIRIN VILLAGE WATER SUPPLY

CONTRACT NO:INF-W02/2022/2023

SCHEDULE B: BULK SUPPLY AND NETWORK DISTRIBUTION WORKS

SECTION 3: MEDIUM PRESSURE PIPELINES AND ANCILLARIES

ITEM NUMBER	LI	PAYMENT CLAUSE	DESCRIPTION	UNIT	QUANTITY	RATE	AMOUNT
SUB-TOTAL SCHEDULE B - SECTION 3 BROUGHT FORWARD:							-
B.3			MEDIUM PRESSURE PIPES: <i>(As specified in SABS 1200 L, SABS 1200 GA and the Project Specifications.)</i>				
3.9	LI	8.2.2	Specials and Fittings - Saddles: <i>(Cast iron, bitumen dipped saddle to be 25 mm BSP drilling and tapping.)</i>				
3.9.1	LI		75 mm dia.	No.	356.00		
3.9.2	LI		160 mm dia.	No.	53.00		
3.10	LI	8.2.3	Specials and Fittings - Isolating Valves: <i>(Flanged RSV isolating valves. Valves to be non-rising spindles with cap top.)</i>				
3.10.1	LI		80 mm dia. Class 16	No.	30.00		
3.10.2	LI		160 mm dia. Class 16	No.	10.00		
3.11	LI	8.2.3	Specials and Fittings - Socketed Valves: <i>(Socket ends RSV isolating valves. Valves to be non-rising spindles with cap top.)</i>				
3.11.1	LI		75 mm dia. Class 16	No.	30.00		
3.11.2	LI		160 mm dia. Class 16	No.	10.00		
3.12	LI	8.2.3	Specials and Fittings - Air Valve: <i>(Vent O' Mat SERIES RBX with screwed BSP male inlet, or similar. Complete with flange, barrel nipple, and 50 mm gate valve)</i>				
3.12.1	LI		50 mm Air Valve	No.	3.00		
3.13	LI	8.2.3	Specials and Fittings - Bulk Water Meter: <i>(Kent or similar approved, flanged and drilled to SABS 1123, Table 16)</i>				
3.13.1	LI		80 mm dia. In-Line Bulk Water Meter.	No.	1.00		
3.13.2	LI		150 mm dia. In-Line Bulk Water Meter.	No.	1.00		
3.14	LI	8.2.3	Flow Control Valves <i>(Bermad or similar approved, flanged and drilled to SABS 1123, Table 16)</i>				
3.14.1			Provisional Sum for the supply of 150 mm dia. In-Line Flow Control Valves.	No.	1.00		Rate Only
SUB-TOTAL SCHEDULE B - SECTION 3 CARRIED FORWARD:							

CAPRICORN DISTRICT MUNICIPALITY - LIMPOPO PROVINCE

ORB.NAIR.2021

SCHEDULE OF QUANTITIES:

NAIRIN VILLAGE WATER SUPPLY

CONTRACT NO:INF-W02/2022/2023

SCHEDULE B: BULK SUPPLY AND NETWORK DISTRIBUTION WORKS

SECTION 3: MEDIUM PRESSURE PIPELINES AND ANCILLARIES

ITEM NUMBER	LI	PAYMENT CLAUSE	DESCRIPTION	UNIT	QUANTITY	RATE	AMOUNT
SUB-TOTAL SCHEDULE B - SECTION 3 BROUGHT FORWARD:							-
B.3			MEDIUM PRESSURE PIPES: <i>(As specified in SABS 1200 L, SABS 1200 GA and the Project Specifications.)</i>				
3.14	LI	8.2.2	Specials and Fittings - Stand Pipes				
3.14.1	LI		Stand pipe fittings complete, excluding saddles, including all labour, plant and incidentals as per DWAF details.	No.	409.00		
3.14.2	LI		Supply and Installation of 15mm Kent Water meter brass type for household connections all complete as per project specifications	No.	409.00		
3.15	LI	8.2.2	Pipe Specials - Galvanised:				
3.15.1	LI		80 mm dia. x 300 mm long GMS pipe, flanged both ends, drilled to SABS 1123 Table 16.	No.	3.00		
3.15.2	LI		150 mm dia air valve chamber vent as per details.	No.	3.00		
3.16	LI	8.2.13	Valve Chambers:				
3.16.1	LI		Valve chamber - 1200 mm x 1400 mm x 1000 mm depth, complete including excavation, materials, plant, labour and incidentals, as per detail drawings.	No.	91.00		
3.16.2	LI		Extra-over Item 3.15.1 for depth increments of 250 mm.	No.	2.00		
3.17	LI		Standpipes:				
3.17.1	LI		Stand pipe complete, excluding specials and fittings, including all labour, plant, materials and incidentals, as per detail drawings.	No.	409.00		
3.18		8.2.1	Hydraulic Pipe Testing:				
3.18.1			75 mm dia. Pipes	m	29,500.00		
3.18.2			160 mm dia. Pipes	m	5,000.00		
3.18.3			25 mm HDPE PN 20	m	6,500.00		
3.18.4			Pipe specials and fittings for testing.	Sum	1.00		
3.19	LI	8.2.1	Disinfecting Pipe Works.				
3.19.1	LI		75 mm dia. Pipes	m	29,500.00		
3.19.2	LI		160 mm dia. Pipes	m	5,000.00		
3.19.3	LI		200 mm dia. Pipes	m	6,500.00		
SUB-TOTAL SCHEDULE B - SECTION 3 CARRIED FORWARD:							

CAPRICORN DISTRICT MUNICIPALITY - LIMPOPO PROVINCE

ORB.NAIR.2021

SCHEDULE OF QUANTITIES:

NAIRIN VILLAGE WATER SUPPLY

CONTRACT NO:INF-W02/2022/2023

SCHEDULE B: BULK SUPPLY AND NETWORK DISTRIBUTION WORKS

SECTION 3: MEDIUM PRESSURE PIPELINES AND ANCILLARIES

ITEM NUMBER	LI	PAYMENT CLAUSE	DESCRIPTION	UNIT	QUANTITY	RATE	AMOUNT
SUB-TOTAL SCHEDULE B - SECTION 3 BROUGHT FORWARD:							-
B.3			MEDIUM PRESSURE PIPES: <i>(As specified in SABS 1200 L, SABS 1200 GA and the Project Specifications.)</i>				
3.20	LI	8.2.11	Thrust Blocks:				
3.20.1			Excavation.	m ³	273.00		
3.20.2			Formwork.	m ²	546.00		
3.20.3			Concrete. [Class 20/19 MPa]	m ³	38.00		
3.21			Pipe Works Ancillaries:				
3.21.1			550 mm x 550 mm Fabricated manhole cover with frame, galvanised.	No.	91.00		
3.21.2			Access ladder - 304 SS, galvanised.	No.	91.00		
3.21.3			Concrete pipe line markers as per details.	No.	174.00		
TOTAL SCHEDULE B - SECTION 3 CARRIED TO SUMMARY:							

CAPRICORN DISTRICT MUNICIPALITY - LIMPOPO PROVINCE

ORB.NAIR.2021

SCHEDULE OF QUANTITIES:

NAIRIN VILLAGE WATER SUPPLY

CONTRACT NO:INF-W02/2022/2023

SCHEDULE B: BULK SUPPLY AND NETWORK DISTRIBUTION WORKS

SECTION 4: ANCILLARY WATER SUPPLY WORKS

ITEM NUMBER	PAYMENT CLAUSE	DESCRIPTION	UNIT	QUANTITY	RATE	AMOUNT
B.4		ANCILLARY WORKS: <i>(As specified in the Project Specifications.)</i>				
4.1	PSH 4.1	Elevated Pressed Steel Reservoir: <i>(Reservoir shall be a Braithwaite type, or similar,pressed steel. All manufacturing to SABS standards with hot dip galvanising to SANS 121(ISO 1461), Installation to be performed by the supplier)</i>				
4.1.1		Supply and erect 331 kl capacity elevated pressed steel reservoir with base 15.0m above natural ground level.	No.	1.00		
4.1.2		Excavating in soft material for maximum depth of 2.0m for the tank footings.	m ³	20.00		
4.1.3		Extra over subitem 4.1.3 for excavation in hard material, irrespective of depth.	m ³	8.00		
4.1.4		Supply, bend and fixing of High yield stress steel reinforcement for the tank footings.	t	0.40		
4.1.5		Supply, bend and fixing of Mild stress steel reinforcement for the tank footings.	t	0.05		
4.1.6		Vertical formwork to provide Class F1 surface finish to the tank footings.	m ²	20.00		
4.1.7		Supply and placement of blinding layer concrete. [Class 15/10 MPa] for the tank footings.	m ³	6.00		
4.1.8		Supply and placement of reinforced concrete. [Class 25/19 MPa] for the tank footings.	m ³	25.00		
4.1.9		Supply and install Ø24mm x 700mm long holding bolts to be casted in the tank footings.	No.	40.00		
SUB-TOTAL SCHEDULE B - SECTION 4 CARRIED FORWARD:						-

CAPRICORN DISTRICT MUNICIPALITY - LIMPOPO PROVINCE

ORB.NAIR.2021

SCHEDULE OF QUANTITIES:

NAIRIN VILLAGE WATER SUPPLY

CONTRACT NO:INF-W02/2022/2023

SCHEDULE B: BULK SUPPLY AND NETWORK DISTRIBUTION WORKS

SECTION 4: ANCILLARY WATER SUPPLY WORKS

ITEM NUMBER	PAYMENT CLAUSE	DESCRIPTION	UNIT	QUANTITY	RATE	AMOUNT
SUB-TOTAL SCHEDULE B - SECTION 4 BROUGHT FORWARD:						
B.4		ANCILLARY WORKS: <i>(As specified in the Project Specifications.)</i>				
4.2		Borehole Development: Re-drilling and Equipping Boreholes				
4.2.1		Re-drilling and or rehabilitation of Borehole H11-2768 including yield test and chemical analysis reporting. Borehole depth up to 120m	Sum	2.00	-	Rate Only
4.2.2		Supply and equip new Boreholes with a suitably sized 3 phase electric motor. Unit complete with starter panel, cabling, valves, flow meter and delivery pipework as per drawing No:NAIR-STD-12	No.	5.00		-
4.2.3		Allow a Provisional Sum for removing, cleaning and handing over to the Engineer existing Boreholes 1372 diesel engine equipment.	Prov Sum	1.00	R 80,000.00	R 80,000.00
4.2.4		Supply and install precast concrete pump house as per DWS specifications, complete with heavy duty lockable steel access door for boreholes above.	No.	7.00		
4.2.5		Provision for ESKOM Connection	Prov.Sum	7.00	R 150,000.00	R 1,050,000.00
4.2.6		Overheads, charges and profit on items 4.2.3 & 4.2.5	%	1,130,000.00		
4.3		Palisade Fencing				
4.3.1		Supply, delivery and installation of 2.4 m high concrete palisade fence with 4.5m wide steel sliding gate, all inclusive of area clearance, civil foundations and all details as per drawing NAIR-STD-09 &10	m			
TOTAL SCHEDULE B - SECTION 4 CARRIED TO SUMMARY:						-

CAPRICORN DISTRICT MUNICIPALITY - LIMPOPO PROVINCE

ORB.NAIR.2021

SUMMARY SCHEDULE OF QUANTITIES

NAIRIN VILLAGE WATER SUPPLY

CONTRACT NO:INF-W02/2022/2023

CALCULATION OF TENDER SUM

SCHEDULE	SECTION	SECTION DESCRIPTION	TENDERED AMOUNT
A	PRELIMINARY AND GENERAL:		
A	1	FIXED CHARGE AND VALUE RELATED OBLIGATIONS	
A	2	TIME RELATED OBLIGATIONS	
A	3	PROVISIONAL SUMS	
A	4	PRIME COST SUMS	
A	5	DAYWORKS	
A	6	TEMPORARY WORKS	
TOTAL SCHEDULE A:			-
B	BULK SUPPLY AND NETWORK DISTRIBUTION WORKS:		
B	1	EARTHWORKS FOR PIPE TRENCHES	-
B	2	PIPE BEDDING	-
B	3	MEDIUM PRESSURE PIPELINES AND ANCILLARIES	-
B	4	ANCILLARY WATER SUPPLY WORKS	-
TOTAL SCHEDULE B:			-

TOTAL AMOUNT - SCHEDULE A:	-
TOTAL AMOUNT – SCHEDULE B:	-
TENDER SUM:	-
CONTINGENCIES [10.00%]:	-
CONTRACT PRICE ADJUSTMENT (CPA)(2.5%):	
SUB-TOTAL:	-
VAT [15.00%]:	-
TENDER PRICE:	-



CAPRICORN DISTRICT MUNICIPALITY

C4.1 Scope of Work

4.1.1 Employer's objectives

The employer's objectives are to deliver public infrastructure using labour intensive method in accordance with EPWP Guidelines, whereby the local community benefit throughout the entire project and also in doing so provide work place training opportunities to learners who have a Learnership Agreements with the Construction Education and Training Authority.

Labour-intensive works

Labour-intensive works shall be constructed/maintained using local workers who are temporarily employed in terms of this Scope of Work.

Labour-intensive competencies of supervisory and management staff

Contractors shall engage supervisory and management staff in labour-intensive works that have completed the skills programme including Foremen/Supervisors at NQF "National Certificate: Supervision of Civil Engineering Construction Processes" and Site Agent/Manager at NQF level 5 "Manage labour-intensive Construction Processes" or equivalent QCTO qualifications.

4.1.2 Overview of the works

On this Contract the aim is to provide a basic level of services, with regards to improve aspects of the current conditions. The Contract will entail a provision of the services as listed in the Project Specification. Also with regards to EPWP requirements, labour-intensive works comprise the activities described in SANS 1921-5, Earthworks activities which are to be performed by hand, and its associated specification data. Such works shall be constructed using local workers who are temporarily employed in terms of this Scope of Work. Time is of the essence for this contract. The Tenderer shall state the time in calendar months required by him/her to complete the Works. Tenderers offering early completion dates will generally be more favourably received, other things being equal.

The following activities are to be carried out:

Water Supply Distribution Networks

Construction of 41 km Water supply distribution network pipelines with valves and all ancillary works as follows:

- Metered Yard connections (409 off) with a 6.5km PN20 of 25mm diameter.
- 75mm diameter uPVC class 9 at (29.5 km)
- 160mm diameter uPVC class 9 at (5 km)

Bulk water Supply Distribution Networks

Construction of 2.5 km bulk main line with valves and all ancillary works as follows:

- Bulk water pipeline of 160mm diameter uPVC class 12 at (2.50 km) package plant to storage.

Storage Reservoirs

- Construction of 302kl capacity elevated steel reservoir

Water Treatment Works

- included in Inveraam scope of work

Boreholes

- 7 Boreholes to be constructed

Security

- Installation of 2.4m concrete palisade fence around the steel tank

4.1.3 Labour-Intensive Works

All the relevant tasks/works shall be constructed using Labour-Intensive Construction Methods only.

4.1.4 Location of the works

The project site is located approximately 90km North West of Polokwane, in the Limpopo province. It is positioned on the western side of the R521 from Polokwane to Alldays. The central coordinates of project site are as follows:

Ga-Molefe Village:

- Longitude: (E) 29° 02' 07.96"
- Latitude: (S) 23° 08' 31.69"

Sifihlampsana Village:

- Longitude: (E) 29° 02' 02.18"
- Latitude: (S) 23° 09' 05.04"

Ga-Tshabalala Village:

- Longitude: (E) 29° 00' 54.67"
- Latitude: (S) 23° 09' 07.24"

Locality Details

- Province : Limpopo Province
- District : Capricorn District Municipality
- Municipality: Blouberg Local Municipality

4.1.5 Temporary works

The Contractor shall provide, erect, maintain and remove on completion of the Contract, temporary offices and sheds for the storage of perishable materials and for the use of his workmen.

4.1.6 General Information

Labour Regulations

C3.1.7.1 Payment for the labour-intensive component of the works

Payment for works identified in clause 2.3 "the Extent of the Project" in the Project Specifications as being labour-intensive shall only be made in accordance with the provisions of the Contract if the works are constructed strictly in accordance with the provisions of the scope of work. Any non-payment for such works shall not relieve the Contractor in any way from his obligations either in contract or in delict.

C3.1.7.2 Applicable labour laws

The Ministerial Determination for Special Public Works Programmes, issued in terms of the Basic Conditions of Employment Act of 1997 by the Minister of Labour in **Government Notice N° R949 in Government Gazette 33665 of 22 October 2010**, as reproduced below, shall apply to works described in the scope of work as being labour intensive and which are undertaken by unskilled or semi-skilled workers.

C3.1.7.3 Introduction

This document contains the standard terms and conditions for workers employed in elementary occupations on a Special Public Works Programme (SPWP). These terms and conditions do NOT apply to persons employed in the supervision and management of a SPWP.
In this document –

- (a) "Department" means any department of the State, implementing agent or contractor;

- (b) “Employer” means any department, implementing agency or contractor that hires workers to work in elementary occupations on a SPWP;
- (c) “Worker” means any person working in an elementary occupation on a SPWP;
- (d) “Elementary occupation” means any occupation involving unskilled or semi-skilled work;
- (e) “Management” means any person employed by a department or implementing agency to administer or execute an SPWP;
- (f) “Task” means a fixed quantity of work;
- (g) “task-based work” means work in which a worker is paid a fixed rate for performing a task;
- (h) “task-rated worker” means a worker paid on the basis of the number of tasks completed;
- (i) “time-rated worker” means a worker paid on the basis of the length of time worked.

C3.1.7.4 Terms of Work

- (a) Workers on a SPWP are employed on a temporary basis.
- (b) A worker may NOT be employed for longer than 24 months in any five-year cycle on a SPWP.
- (c) Employment on a SPWP does not qualify as employment as a contributor for the purposes of the Unemployment Insurance Act 30 of 1966.

C3.1.7.5 Normal Hours of Work

An employer may not set tasks or hours of work that require a worker to work–

- (a) More than forty hours in any week
- (b) On more than five days in any week; and
- (c) For more than eight hours on any day.
- (d) An employer and worker may agree that a worker will work four days per week. The worker may then work up to ten hours per day.
- (e) A task-rated worker may not work more than a total of 55 hours in any week to complete the tasks allocated (based on a 40-hour week) to that worker.

C3.1.7.6 Meal Breaks

- (a) A worker may not work for more than five hours without taking a meal break of at least thirty minutes duration.
- (b) An employer and worker may agree on longer meal breaks.
- (c) A worker may not work during a meal break. However, an employer may require a worker to perform duties during a meal break if those duties cannot be left unattended and cannot be performed by another worker. An employer must take reasonable steps to ensure that a worker is relieved of his or her duties during the meal break.
- (d) A worker is not entitled to payment for the period of a meal break. However, a worker who is paid on the basis of time worked must be paid if the worker is required to work or to be available for work during the meal break.

C3.1.7.7 Special Conditions for Security Guards

- (a) A security guard may work up to 55 hours per week and up to eleven hours per day.
- (b) A security guard who works more than ten hours per day must have a meal break of at least one hour or two breaks of at least 30 minutes each.

C3.1.7.8 Daily Rest Period

- (a) Every worker is entitled to a daily rest period of at least eight consecutive hours. The daily rest period is measured from the time the worker ends work on one day until the time the worker starts work on the next day.

C3.1.7.9 Weekly Rest Period

- (a) Every worker must have two days off every week. A worker may only work on their day off to perform work which must be done without delay and cannot be performed by workers during their ordinary hours of work (“emergency work”).

C3.1.7.10 Work on Sundays and Public Holidays

- (a) A worker may only work on a Sunday or public holiday to perform emergency or security work.
- (b) Work on Sundays is paid at the ordinary rate of pay.
- (c) A task-rated worker who works on a public holiday must be paid –
 - i. the worker’s daily task rate, if the worker works for less than four hours;
 - ii. Double the worker’s daily task rate, if the worker works for more than four hours.
- (d) A time-rated worker who works on a public holiday must be paid –
 - i. the worker’s daily rate of pay, if the worker works for less than four hours on the public holiday;
 - ii. Double the worker’s daily rate of pay, if the worker works for more than four hours on the public holiday.

C3.1.7.11 Sick Leave

- (a) Only workers who work four or more days per week have the right to claim sick-pay in terms of this clause.
- (b) A worker who is unable to work on account of illness or injury is entitled to claim one day’s paid sick leave for every full month that the worker has worked in terms of a contract.
- (c) A worker may accumulate a maximum of twelve days’ sick leave in a year.
- (d) Accumulated sick-leave may not be transferred from one contract to another contract.
- (e) An employer must pay a task-rated worker the worker’s daily task rate for a day’s sick leave.
- (f) An employer must pay a time-rated worker the worker’s daily rate of pay for a day’s sick leave.
- (g) An employer must pay a worker sick pay on the worker’s usual payday.

- (h) Before paying sick-pay, an employer may require a worker to produce a certificate stating that the worker was unable to work on account of sickness or injury if the worker is –
 - i. absent from work for more than two consecutive days; or
 - ii. Absent from work on more than two occasions in any eight-week period.
- (i) A medical certificate must be issued and signed by a medical practitioner, a qualified nurse or a clinic staff member authorised to issue medical certificates indicating the duration and reason for incapacity.
- (j) A worker is not entitled to paid sick-leave for a work-related injury or occupational disease for which the worker can claim compensation under the Compensation for Occupational Injuries and Diseases Act.

C3.1.7.12 Maternity Leave

- (a) A worker may take up to four consecutive months' unpaid maternity leave.
- (b) A worker is not entitled to any payment or employment-related benefits during maternity leave.
- (c) A worker must give her employer reasonable notice of when she will start maternity leave and when she will return to work.
- (d) A worker is not required to take the full period of maternity leave. However, a worker may not work for four weeks before the expected date of birth of her child or for six weeks after the birth of her child, unless a medical practitioner, midwife or qualified nurse certifies that she is fit to do so.
- (e) A worker may begin maternity leave –
 - (f) four weeks before the expected date of birth; or
 - (g) on an earlier date –
 - (i) if a medical practitioner, midwife or certified nurse certifies that it is necessary for the health of the worker or that of her unborn child; or
 - (ii) if agreed to between employer and worker; or
 - (iii) on a later date, if a medical practitioner, midwife or certified nurse has certified that the worker is able to continue to work without endangering her health.
- (h) A worker who has a miscarriage during the third trimester of pregnancy or bears a stillborn child may take maternity leave for up to six weeks after the miscarriage or stillbirth.
- (i) A worker, who returns to work after maternity leave, has the right to start a new cycle of twenty-four months employment, unless the SPWP on which she was employed has ended.

C3.1.7.12 Family responsibility leave

Workers, who work for at least four days per week, are entitled to three days paid family responsibility leave each year in the following circumstances –

- (a) when the employee's child is born;
- (b) when the employee's child is sick;
- (c) in the event of a death of –
 - (i) the employee's spouse or life partner;

- (ii) the employee's parent, adoptive parent, grandparent, child, adopted child, grandchild or sibling.

C3.1.7.13 Statement of Conditions

An employer must give a worker a statement containing the following details at the start of employment –

- (a) the employer's name and address and the name of the SPWP;
- (b) the tasks or job that the worker is to perform; and
- (c) the period for which the worker is hired or, if this is not certain, the expected duration of the contract;
- (d) the worker's rate of pay and how this is to be calculated;
- (e) the training that the worker will receive during the SPWP.
- (f) An employer must ensure that these terms are explained in a suitable language to any employee who is unable to read the statement.
- (g) An employer must supply each worker with a copy of these conditions of employment.

C3.1.7.14 Keeping Records

Every employer must keep a written record of at least the following –

- (a) the worker's name and position;
- (b) in the case of a task-rated worker, the number of tasks completed by the worker;
- (c) in the case of a time-rated worker, the time worked by the worker;
- (d) payments made to each worker.
- (e) The employer must keep this record for a period of at least three years after the completion of the SPWP.

C3.1.7.15 Payment

- (a) An employer must pay all wages at least monthly in cash or by cheque or into a bank account.
- (b) A task-rated worker will only be paid for tasks that have been completed.
- (c) An employer must pay a task-rated worker within five weeks of the work being completed and the work having been approved by the manager or the contractor having submitted an invoice to the employer.
- (d) A time-rated worker will be paid at the end of each month.
- (e) Payment must be made in cash, by cheque or by direct deposit into a bank account designated by the worker.
- (f) Payment in cash or by cheque must take place –
 - i. at the workplace or at a place agreed to by the worker;
 - ii. during the worker's working hours or within fifteen minutes of the start or finish of work;
 - iii. in a sealed envelope which becomes the property of the worker.

C3.1.7.16 An employer must give a worker the following information in writing –

- (a) the period for which payment is made;
- (b) the numbers of tasks completed or hours worked;
- (c) the worker's earnings;
- (d) any money deducted from the payment;
- (e) the actual amount paid to the worker.
- (f) If the worker is paid in cash or by cheque, this information must be recorded on the envelope and the worker must acknowledge receipt of payment by signing for it
- (g) If a worker's employment is terminated, the employer must pay all monies owing to that worker within one month of the termination of employment.

C3.1.7.17 Deductions

- (a) An employer may not deduct money from a worker's payment unless the deduction is required in terms of a law.
- (b) An employer must deduct and pay to the SA Revenue Services any income tax that the worker is required to pay.
- (c) An employer who deducts money from a worker's pay for payment to another person must pay the money to that person within the time period and other requirements specified in the agreement law, court order or arbitration award concerned.
- (d) An employer may not require or allow a worker to –
 - i. repay any payment except an overpayment previously made by the employer by mistake;
 - ii. state that the worker received a greater amount of money than the employer actually paid to the worker; or
 - iii. pay the employer or any other person for having been employed.

C3.1.7.18 Health and Safety

- (a) Employers must take all reasonable steps to ensure that the working environment is healthy and safe.
- (b) A worker must –
 - i. work in a way that does not endanger his/her health and safety or that of any other person;
 - ii. obey any health and safety instruction;
 - iii. obey all health and safety rules of the SPWP;
 - iv. use any personal protective equipment or clothing issued by the employer;
 - v. report any accident, near-miss incident or dangerous behaviour by another person to their employer or manager.

C3.1.7.19 Compensation for Injuries and Diseases

- (a) It is the responsibility of the employers (other than a contractor) to arrange for all persons employed on a SPWP to be covered in terms of the Compensation for

Occupational Injuries and Diseases Act, 130 of 1993.

- (b) A worker must report any work-related injury or occupational disease to their employer or manager.
- (c) The employer must report the accident or disease to the Compensation Commissioner.
- (d) An employer must pay a worker who is unable to work because of an injury caused by an accident at work 75% of their earnings for up to three months. The employer will be refunded this amount by the Compensation Commissioner. This does NOT apply to injuries caused by accidents outside the workplace such as road accidents or accidents at home.

C3.1.7.20 Termination

The employer may terminate the employment of a worker for good cause after following a fair procedure.

- (a) A worker will not receive severance pay on termination.
- (b) A worker is not required to give notice to terminate employment. However, a worker who wishes to resign should advise the employer in advance to allow the employer to find a replacement.
- (c) A worker who is absent for more than three consecutive days without informing the employer of an intention to return to work will have terminated the contract. However, the worker may be re-engaged if a position becomes available for the balance of the 24-month period.
- (d) A worker who does not attend required training events, without good reason, will have terminated the contract. However, the worker may be re-engaged if a position becomes available for the balance of the 24-month period.

C3.1.7.21 Certificate of Service

On termination of employment, a worker is entitled to a certificate stating –

- (a) the worker's full name;
- (b) the name and address of the employer;
- (c) the SPWP on which the worker worked;
- (d) the work performed by the worker;
- (e) any training received by the worker as part of the SPWP;
- (f) the period for which the worker worked on the SPWP;
- (g) any other information agreed on by the employer and worker.

C3.1.7.22 Contractor's default in payment to Labourers and Employees

- (a) Any dispute between the Contractor and labourers, regarding delayed payment or default in payment of fair wages, if not resolved immediately may compel the Employer to intervene.
- (b) The Employer may, upon the Contractor defaulting payment, pay the moneys due to the workers not honoured in time, out of any moneys due or which may become due to the Contractor under the Contract.

C3.1.7.23 Provision of Hand tools

- (a) The Contractor shall provide his labour force with hand tools of adequate quality, sufficient in numbers and make the necessary provisions to maintain the tools in good and safe working conditions

C3.1.7.23 Reporting

The Contractor shall submit monthly returns/reports as specified below:

- (a) Signed Muster rolls/pay sheets of temporary workers and permanent staff detailing the number, category, gender, rate of pay and daily attendance.
- (b) Copies of identity documents of workers
- (c) Number of persons who have attended training including nature and duration of training provided
- (d) Assets created, rehabilitated or maintained in accordance with indicators in the EPWP M&E framework
- (e) Plant utilization returns

Progress report detailing production output compared to the programme of works



CAPRICORN DISTRICT MUNICIPALITY

C4.2 Drawing Descriptions

The following drawings are applicable to the contract:

4.2.1 Key plans

All key plans for this type of project are included in the tender document as “Part C.8 Drawings”.

4.2.2 Typical details

All typical details for this type of project are included in the tender document as “Part C.8 Drawings”.

4.2.3 Civil engineering drawings

The drawings used for setting up the Bills of Quantities are as indicated above in paragraph 4.2.1 and 4.2.2.



CAPRICORN DISTRICT MUNICIPALITY

C4.3 Procurement

3.4.1 Preferential procurement procedures

The works shall be executed in accordance with the conditions attached to preferences granted in accordance with the referencing schedule.

3.4.2 Scope of mandatory subcontract work

The following portions of the works shall be subcontracted to CIDB registered contractors in accordance with the subcontracting procedures described hereunder:

Competitive Bids shall be invited in respect of each of the above portions of the works in accordance with the relevant provisions of the latest edition of the CIDB Standard for Uniformity in Construction Procurement. The Contract Data in the associated procurement documents shall be based on the use of BIFSA Non-Nominated Subcontract for use with the JBCC Series 2000 Principal Building Agreement / CIDB Standard subcontract (labour only) / JBCC series 2000 Nominated / Selected Subcontract Agreement / SAFCEC General conditions of subcontract (2003 edition) (select appropriate option) / NEC Engineering and Construction Subcontract / NEC Engineering and Construction Short Subcontract with minimal project specific variations and amendments that do not change their intended usage.

The Employer together with the Contractor shall evaluate the Bids received in accordance with the provisions of the Standard Conditions of Bid contained in Annex F of Standard for Uniformity in Construction Procurement. The evaluation panel shall comprise equal representatives from the Employer and from the Contractor.

The Contractor shall without delay enter into contract with the successful Bidding subcontractor based on their accepted Bid submission. The Contractor shall remain responsible for providing the subcontracted portion of the works as if the work had not been subcontracted.



CAPRICORN DISTRICT MUNICIPALITY

C4.4 Construction

4.4.1 Setting out of Works (Sub clause 5.1.1)

The Employer shall arrange for the Contractor to be given sufficient reference pegs from which to work. The value of all bench marks shall be given in writing. The Contractor shall bear the cost of any re-survey and the cost of re-establishment or checking of any pegs, bench marks, etc. disturbed, destroyed or interfered with in any way and the cost of any survey to prove the accuracy of the setting out after any disturbance of or interference with any peg or bench mark. All surveys or re-survey shall be by Surveyors appointed by the Employer.”

4.4.2 Applicable national and international standards

SANS 1200

4.4.3 Particular / generic specifications

The relevant provisions of the SANS 1200 (1981 edition) shall apply to the contract with the following amendments:

1115 Replace clause with the following:

The general conditions of contract are the General Conditions of Contract for Construction Works (2015) as published by the South African Institution of Civil Engineering read in conjunction with the Contract Data.

1202 Replace “Clause 15” with “Clause 12”.

1206 Replace the first sentence with the following:

The contractor shall comply with all legal provisions in regard to surveying and setting out work.

1209(e) Replace “Clause 52” with “Clauses 29 and 49.2”.

1210 Replace “Clause 54” with “Clause 51”.

1212(1) Replace “Clause 49” with “Clause 46”.

1215 Replace “Clause 45” with “Clause 42”.

1217 Replace “Clause 35” with “Clause 31”.

1303 Replace “Clauses 49 and 53” with “Clause 50”.

13.01(3) Replace “Clauses 12 and 45” with “Clauses 1.1.4 and 42”.

14.03(c) Replace “Clause 40(1)” with “Clause 37”.

1505 Replace “Clauses 40 and 53” with “Clause 37”.

3204(b) (iii) Replace “Clauses 40 and 53” with “Clause 37”.

4.4.4 EPWP labour intensive specification

EXPANDED PUBLIC WORKS PROGRAMME (EPWP) LABOUR INTENSIVE SPECIFICATION
(Read with SANS 1914 -5 2002 and Guidelines for the implementation of Labour-Intensive Infrastructure Projects under the Expanded Public Works Programme (EPWP) third edition 2015)

4.4.4.1 Labour intensive competencies of supervisory and management staff

Contractors having a CIDB contractor grading designation of **6 CEPE/7CE or higher** shall only engage supervisory and management staff in labour intensive works who have either completed, or for the period 1 April 2012 to 30 June 2013, are registered for training towards, the skills programme outlined in Table 1.

The managing principal of the contractor, namely, a sole proprietor, the senior partner, the managing director or managing member of a close corporation, as relevant, having a contractor grading designation of **6 CEPE/7 CE or higher** shall have personally completed, or for the period 1 April 2013 to 30 July 2013 be registered on a skills programme for the NQF level 2. All other site supervisory staff in the employ of such contractors must have completed, or for the period 1 April 2012 to 30 June 2013 be registered on a skills programme for, the NQF level 2 unit standards or NQF level 4 unit standards.

Table 1: Skills programme for supervisory and management staff

Personnel	NQF level	Unit standard titles	Skills programme description
Team leader / supervisor	2	Apply Labour Intensive Construction Systems and Techniques to Work Activities	This unit standard must be completed, and any one of these 3 unit standards
		Use Labour Intensive Construction Methods to Construct and Maintain the Pump Station	
		Use Labour Intensive Construction Methods to Construct and Maintain Water and Sanitation Services	
		Use Labour Intensive Construction Methods to Construct, Repair and Maintain Structures	
Foreman/ supervisor	4	Implement labour Intensive Construction Systems and Techniques or the equivalent QCTO qualification	This unit standard must be completed, and any one of these 3 unit standards
		Use Labour Intensive Construction Methods to Construct and Maintain Roads and Stormwater Drainage or the equivalent QCTO qualification	
		Use Labour Intensive Construction Methods to Construct and Maintain Water and Sanitation Services or the equivalent QCTO qualification	
		Use Labour Intensive Construction Methods to Construct, Repair and Maintain Structures or the equivalent QCTO qualification	
Site Agent / Manager (i.e. the contractor's most senior representative that is resident on the site)	5	Manage Labour Intensive Construction Processes or the equivalent QCTO qualification	Skills Programme against this single unit standard

4.4.4.2 Employment of unskilled and semi-skilled workers in labour-intensive works

4.4.4.2.1 Requirements for the sourcing and engagement of labour.

4.4.4.2.1.1 Unskilled and semi-skilled labour required for the execution of all labour intensive works shall be engaged strictly in accordance with prevailing legislation and SANS 1914-5, Participation of Targeted Labour.

- 4.4.4.2.1.2 The rate of pay set for the SPWP is **R 160 per task or per day**. Rate to be confirmed with client during construction stage.
- 4.4.4.2.1.3 Tasks established by the contractor must be such that:
- a) the average worker completes 5 tasks per week in 40 hours or less; and
 - b) the weakest worker completes 5 tasks per week in 55 hours or less.
- 4.4.4.2.1.4 The contractor must revise the time taken to complete a task whenever it is established that the time taken to complete a weekly task is not within the requirements of 3.4.4.2.1.3.
- 4.4.4.2.1.5 The Contractor shall, through all available community structures, inform the local community of the labour intensive works and the employment opportunities presented thereby. Preference must be given to people with previous practical experience in construction and / or who come from households:
- a) where the head of the household has less than a primary school education;
 - b) that have less than one full time person earning an income;
 - c) where subsistence agriculture is the source of income.
 - d) those who are not in receipt of any social security pension income
- 4.4.4.2.1.6 The Contractor shall endeavour to ensure that the expenditure on the employment of temporary workers is in the following proportions:
- a) 55 % women;
 - b) 55% youth who are between the ages of 18 and 35; and
 - c) 2% on persons with disabilities.

4.4.4.2.2 Specific provisions pertaining to SANS 1914-5

4.4.4.2.2.1 Definitions

Targeted labour: Unemployed persons who are employed as local labour on the project.

4.4.4.2.2.2 Contract participation goals

- 4.4.4.2.2.2.1 There is no specified contract participation goal for the contract. The contract participation goal shall be measured in the performance of the contract to enable the employment provided to targeted labour to be quantified.
- 4.4.4.2.2.2.2 The wages and allowances used to calculate the contract participation goal shall, with respect to both time-rated and task rated workers, comprise all wages paid and any training allowance paid in respect of agreed training programmes.

4.4.4.2.2.3 Terms and conditions for the engagement of targeted labour

Further to the provisions of clause 3.3.2 of SANS 1914-5, written contracts shall be entered into with targeted labour.

4.4.4.2.2.4 Variations to SANS 1914-5

- 4.4.4.2.2.4.1 The definition for net amount shall be amended as follows:

Financial value of the contract upon completion, exclusive of any value added tax or sales tax which the law requires the employer to pay the contractor.

- 4.4.4.2.2.4.2 The schedule referred to in 5.2 shall in addition reflect the status of targeted labour as women, youth and persons with disabilities and the number of days of formal training provided to targeted labour.

4.4.4.2.2.5 Training of targeted labour

- 4.4.4.2.2.5.1 The contractor shall provide all the necessary on-the-job training to targeted labour to enable such labour to master the basic work techniques required to undertake the work in accordance with the requirements of the contract in a manner that does not compromise worker health and safety.
- 4.4.4.2.2.5.2 The cost of the formal training of targeted labour, will be funded by the provincial office of the Department of Labour. This training should take place as close to the project site as practically possible. The contractor, must access this training by informing the relevant provincial office of the Department of Labour in writing, within 14 days of being awarded the contract, of the likely number of persons that will undergo training and when such training is required. The employer must be furnished with a copy of this request.
- 4.4.4.2.2.5.3 A copy of this training request made by the contractor to the DOL provincial office must also be faxed to the EPWP Training Director in the Department of Public Works, Fax Number 012 328 6820 or email cinderella.makunike@dpw.gov.za Tel: 083 677 4026.
- 4.4.4.2.2.5.4 The contractor shall be responsible for scheduling the training of workers and shall take all reasonable steps to ensure that each beneficiary is provided with a minimum of six (6) days of formal training if he/she is employed for 3 months or less and a minimum of ten (10) days if he she is employed for 4 months or more.
- 4.4.4.2.2.5.5 The contractor shall do nothing to dissuade targeted labour from participating in training programmes.
- 4.2.2.5.4 An allowance equal to 100% of the task rate or daily rate shall be paid by the contractor to workers who attend formal training, in terms of 4.4.4.2.2.5.4 above.
- 4.4.4.2.2.5.5 Proof of compliance with the requirements of 4.4.4.2.2.5.2 to 4.4.4.2.2.5.6 must be provided by the Contractor to the Employer prior to submission of the final payment certificate.

4.4.4.3.1 **Contractor's default in payment to Labourers and Employees**

- (a) Any dispute between the Contractor and labourers, regarding delayed payment or default in payment of fair wages, if not resolved immediately may compel the Employer to intervene.
- (b) The Employer may, upon the Contractor defaulting payment, pay the moneys due to the workers not honoured in time, out of any moneys due or which may become due to the Contractor under the Contract.

4.4.4.3.2 **Provision of Hand tools**

- (a) The Contractor shall provide his labour force with hand tools of adequate quality, sufficient in numbers and make the necessary provisions to maintain the tools in good and safe working conditions

4.4.4.3.3 **Reporting**

The Contractor shall submit monthly returns/reports as specified below:

- (a) Signed Muster rolls/pay sheets of temporary workers and permanent staff detailing the number, category, gender, rate of pay and daily attendance.
- (b) Copies of identity documents of workers
- (c) Number of persons who have attended training including nature and duration of training provided
- (d) Assets created, rehabilitated or maintained in accordance with indicators in the EPWP M&E framework.
- (e) Plant utilization returns
- (f) Progress report detailing production output compared to the programme of works

4.4.5 Plant and equipment

Add Sub-clause 4.4.5: Restriction on the use of plant.

“Except for the type of plant, and to the extent permitted in terms of the project specification or approved by the Engineer, in writing, the Contractor shall use only hand tools and equipment in the construction of the Works, or portion(s) of the Works, that are required in terms of the project specification to be constructed using labour intensive methods.

Failure by the Contractor to adhere to this clause will put him in breach of contract. The provisions contained in this contract with regard to labour content and labour intensive construction, are binding, and will be enforced accordingly.”

The plant and equipment used on the site shall not be inferior to that described in the Schedule of Plant and Equipment.



CAPRICORN DISTRICT MUNICIPALITY

C4.5 Management

4.5.1 Applicable SANS 1921 standards

The following parts of SANS 1921 Construction works standards and associated specification data are applicable to the works:

- 1) SANS 1921-1:2004
- 2) SANS 1921-2:2004
- 3) SANS 1921-6:2004

The abovementioned South African National Standards make several references to the Specification Data for data, provisions and variations that make these standards applicable to this contract. The Specification Data shall have precedence in the interpretation of any ambiguity or inconsistency between it and these standards.

Each item of Specification Data given below is cross-referenced to the clause in the standard to which it mainly applies.

The associated Specification Data is as follows:

SANS 1921-1, Construction and management requirements for works contracts – Part 1: General engineering and construction works	
Clause	Specification data
Essential data	
4.1.7	There are no requirements for drawings, information and calculations for which the contractor is responsible
4.2.1	The responsibility strategy assigned to the contractor for the works is A.
4.3.1	The planning, programme and method statements are to comply with the following: <ul style="list-style-type: none"> • format of programme, • critical path activities and their dependencies, • frequency of updating,
4.3.3	The notice period for inspection is 5 Days
4.7.3	The over break allowances for blasting are provided for in the scope of work.
4.9.3	The trees and shrubs which are not to be disturbed are identified in the scope of work.
4.12.2	The samples of materials, workmanship and finishes that the contractor is to provide and deliver to the employer are: <ol style="list-style-type: none"> 1) concrete works 2) Pressure testing results done.
4.14.3	The office accommodation, equipment, accommodation for site meetings and other facilities for use by the employer and his agents are:

	<p>1) Site office which shall be used for site meetings and for the contractor's use. Such an office shall comprise a minimum of 20m² in area and 3 m high, be ventilated, have good lamination, must be reasonably sound proof, and have a hard floor construction. It shall be furnished with a desk on which drawings can be rolled open and on which there is sufficient writing space and sufficient temporary chairs or benches to accommodate all persons present at site meetings.</p>
4.14.5	The Contractor is required to provide latrine and ablution facilities.
4.14.6	<p>The requirements for the provision and erection of separate sign boards for consultants and subcontractors are:</p> <ol style="list-style-type: none"> 1) The boards must comply with the official standard type signboard of the Employer and be at least 2750 x 1800 mm high. 2) The boards must be constructed with a firm flat exposed face using suitable material of firm construction, painted and lettered according to the standard drawings available from the Employer on request and mounted on sturdy pipe-standards at a height of 1800 mm above natural ground level.
4.17.1	<p>The requirements for the termination, diversion or maintenance of existing services are:</p> <ol style="list-style-type: none"> 1) Water 2) Electricity 3) Sanitation
4.17.3	<p>Services which are known to exist on the site are:</p> <ol style="list-style-type: none"> 1) Water 2) Sanitation 3) Electricity
Additional clauses	
<p>1 Site meetings and procedures</p> <p>The Employer's Representative and the Contractor shall hold meetings relating to the progress of the works at regular intervals and at other such times as may be necessary. The Contractor shall attend all site meetings and shall ensure that all persons under his jurisdiction are notified timeously of all site meetings should the Employer's Representative require their attendance at such meetings.</p> <p>The Contractor shall keep on site a set of minutes of all site meetings, daily records of resources (people and equipment employed), a site instruction book, a complete set of contract working drawings and a copy of the procurement document and make these available at all reasonable times to all persons concerned with the contract.</p> <p>2 Water</p> <p>The Contractor is to provide, and remove and make good upon completion, all the necessary temporary plumbing connections and purchase water from the local authority for the works at his own cost.</p> <p>3 Electricity</p> <p>The Contractor is to provide, and remove and make good upon completion, all the necessary temporary electrical connections and installations and purchase electricity form the local authority / ESKOM for the works at his own cost.</p>	

4.5.2 Particular / generic specifications

The management of the site shall be in accordance with the provisions of the SANS Standard Specification, obtainable from the South African Institution of Civil Engineering.

4.5.3 Recording of weather

The Contractor shall erect an effective rainfall gauge on the site and record the daily rainfall figures in a book. Such book shall be handed to the employer's representative for his signature no later than 12 days after rain that is considered to justify an extension of time occurs.

4.5.4 Unauthorised persons

The Contractor shall keep unauthorized persons from the works at all times. Under no circumstances may any person except guards be allowed to sleep on the building site.

4.5.5 Management meetings

Site meetings will be held on monthly basis. The following parties are required to attend these meetings: the Employer's Representative, the Engineer and/or Representative, the Contractor and/or Representative, the Community Liaison Officer, the Health and Safety Officer and all members of the Project Steering Committee.

4.5.6 Forms for contract administration

These forms will be issued to the Contractor as required.

4.5.7 Electronic payments

Proof of all electronic payments must on request be supplied to the Employer.

4.5.8 Daily records

All accidents and incidents shall be recorded daily in a site diary. Apart from the site diary the Contractor shall provide a site instruction notebook for use by the Engineer. The notebook shall be signed by both the Engineer and the Contractor whenever a site instruction is issued by the Engineer.

4.5.9 Payment certificates

Contractor to submit claims for the work done. All claims are subjected to verification by the Engineer.

4.5.10 Permits

Contractor to ensure that no unauthorised persons are permitted to site

4.5.11 Proof of compliance with the law

Contractor to submit copies of the CIDB Registration and the Company Registration Certificates



CAPRICORN DISTRICT MUNICIPALITY

C5. Project Specification

SCOPE

This project specification is set out in two parts. Portion 1 cover a general description of the project, the facilities available, and the requirements to be met. Portion 2 covers variations and additions to standardised or particular specifications that are applicable to the contract.

The numbering method in portion 2 of this project specification deviates as follows from the method suggested in Code of Practice SANS 1200.

Each clause with the prefix PS shall refer to the concurrent clause in the appropriate section of the standardised or particular specification. Such clause shall either substitute, or supplement, or amend the clause with the same number. Where there is no such concurrent clause in the standardised or particular specification, the PS clause shall be a new clause in the project specification. Any clause that is referred to in the standardised specification will also include the appropriate project specification

As much as is economically feasible all work shall be implemented by employing Labour Intensive Construction methods. Over and above the normal Building and Allied works to be implemented by employing skilled and unskilled labour the works specified in the "Guidelines for the Implementation of Labour-Intensive Infrastructure Projects under the Expanded Public Works Programme (EPWP)" shall be undertaken using Labour Intensive Construction methods

PORTION 1: THE WORKS

PS 1 GENERAL DESCRIPTION OF WORKS

Water Supply Distribution Networks

Construction of 41 km Water supply distribution network pipelines with valves and all ancillary works as follows:.

- Metered Yard connections (409 off) with a 6.5km PN20 of 25mm diameter.
- 75mm diameter uPVC class 9 at (29.5 km)
- 160mm diameter uPVC class 9 at (5 km)

Bulk water Supply Distribution Networks

Construction of 2.5 km bulk main line with valves and all ancillary works as follows:

- Bulk water pipeline of 160mm diameter uPVC class 12 at (2.50 km) package plant to storage.

Storage Reservoirs

- Construction of 302kl capacity elevated steel reservoir

Water Treatment Works

- included in inveraan scope of work

Boreholes

- 7 Boreholes to be constructed

Security

- Installation of 2.4m concrete palisade fence around the steel tank

Tenderers must note that certain rates in this tender are fixed and based on prices that the successful Tenderer shall undertake the complete construction of such installations. Tenderers are also to take note of the fact that the bulk of the work is to be executed by means of labour intensive construction (LIC) methods, where feasible. The execution of the work will be done using the two following methods:

- Established contractor to employ people from the communities where the work is to be done.
- Nominated emerging sub-contractors, which are to be employed and trained by the established contractor with the assistance of an approved training institution.

The tenderers must take note of the fact that it will be expected of the successful Tenderer to enter into a formal agreement with the Nominated Emerging Contractors (NEC) and all local labour to be employed on the project. The established/main contractor (MC) will be responsible for the quantity and progress of the work of the nominated emerging contractors.

The work to be carried out during the contract period may be given as separate tasks. Each task to be undertaken will be issued as a written instruction by the Engineer and will consist of a detail scope of work and relevant drawings for each particular task.

PS 2 DESCRIPTION OF THE SITE AND ACCESS

Refer to the “*PART C.7 Site Information*”.

PS 3 DOCUMENTATION

PS 3.1 The Provisional Bill of Quantities is included in this document and *must be completed and handed in with the tender*.

PS 3.2 The drawings, for tender purposes, listed under part C3.2 are applicable to this contract

PS 3.3 The Tenderer shall check the Bills of Quantities for missing or duplicated pages and or drawings and should any be missing or duplicated, or the reproduction be indistinct, or if any doubt exists as to the full intent or meaning of any particulars or description, or this Bills of Quantities contain any obvious errors, the Tenderer shall notify the Engineer at once who shall promptly give a written directive. No liability whatsoever will be admitted in respect of errors in any tender due to the abovementioned causes.

No alteration, erasure, omission or addition is to be made in the text and conditions of these Bills of Quantities or other documents. Should any such alterations, amendment, note or addition is made, it will not be recognised and the text of the Bills of Quantities or other documents as prepared by the Representative must be adhered to.

PS 3.4 The Tenderer shall examine all project documents and shall thoroughly acquaint himself with the nature and extent of the Works and the manner in which they are to be executed as no claim for extra payment will be entertained.

PS 4 NATURE OF GROUND AND SUBSOIL CONDITIONS ON SITE

No bore tests or investigation of the in-situ material were done, over and above the provided information if any.

The water table may be relatively high during the summer months and provision must be made for effective draining of excavations.

It is the Contractor's responsibility to supply and deliver all material that complies with the minimum standards as well as for the building and maintaining of access roads to the works on site, haul areas or dumping sites. No additional payment will be applicable to the above-mentioned, other than the relevant items in the schedule of quantities.

No trial holes were dug along the network layout. Note that the prospective tenderers shall acquaint themselves with the nature of materials on site.

PS 5 DETAILS OF THE CONTRACT

PS 5.1 MAIN CONTRACTS

Work included in this contract involves the scope of work as per paragraph PS1.

The other main components of the work under this contract are:

- a) Establishment of the Contractor's camp.
- b) Site clearance and earthworks.
- c) Provision of all materials, special fittings and accessories as required, to complete the work as prescribed.
- d) Excavation and backfill compacted as specified, of pipe trenches and the removal of all excess material.
- e) Laying, bedding and installation of all pipes and accessories.
- f) Concrete work associated with the abovementioned equipment.
- g) Construction of concrete anchor blocks associated with the above.
- h) Commissioning of the works.
- i) Maintenance on the works for a twelve month period.

PS 6 CONSTRUCTION PROGRAM AND METHODS

The construction site is situated in a built-up area; the Contractor shall ensure the least possible disruption of movement of the public during construction.

Construction methods must be of such a nature that no property or life is endangered. The Employer accepts no responsibility for work that is done without consent by the Engineer outside the site boundaries. The Contractor himself is responsible for liaison and arrangements with the Local Authority in connection with the finalisation and approval of the construction program.

The Contractor is responsible for liaison and the necessary arrangements with the relevant water authorities in respect of the finalisation and approval of the works programme.

Sufficient photos of existing structures, walls, and areas that have to be crossed must be taken by the Contractor and handed over to the Engineer before such operations commence. No payment will be made in this regard and it shall be deemed to be covered in the Preliminary and General items.

Local labourers must do the trench preparation, bedding, handling, laying and backfilling of pipes and fittings. The contractor is responsible to liaise with the Labour Desk for labourers.

No separate payment shall be made for any arrangements with relative local authorities for closing off the current water supply or for the distribution of notices to the public.

The compilation of the construction programme and any amendments thereto during the course of construction shall be at the cost of the Contractor and shall not be measured elsewhere in this contract. The contract has to be completed within the time specified in the "Contract Data" of this document, excluding the builder and public holidays.

PS 7 SITE FACILITIES AVAILABLE

PS 7.1 SOURCES OF WATER SUPPLY, POWER SUPPLY, SANITATION, AND COMMUNICATION

Water for construction purposes will be for the account of the contractor at the ruling tariff and will be supplied at a suitable point, from where the contractor will be responsible to convey the water to the point of usage. Water for human consumption will be from the existing reticulation at the ruling tariff. Electrical power is available from the existing network at ruling tariffs. The Contractor shall make his own arrangement for any water or power he may require. Any extension of time due to delays resulting from these facilities will not be granted.

The Contractor must supply and maintain at his own cost a sufficient number of portable chemical toilets, one of which must be situated at the campsite and the rest in the area of the site.

No waste or sludge must be left uncovered until it is removed. The contractor must operate an efficient solid waste removal system to the satisfaction of the engineer for the duration of the contract.

The Contractor must make his own arrangement for communication and a telephone service.

PS 7.2 LOCATION OF CAMP AND DEPOT

The contractor is responsible for establishment of their own site camp and depot. No trees may be removed and the Contractor must provide his own firewood.

PS 7.3 HOUSING FOR CONTRACTOR'S EMPLOYEES

No housing is made available for the Contractor's employees, and the Contractor shall make his own arrangements for housing his employees or transporting them to and from the site. The Contractor is in all respects responsible for the housing and transporting of his employees, and for the arrangement thereof, and no extension of time due to any delays resulting from this, will be granted.

PS 8 SITE FACILITIES REQUIRED

No housing is required for the Engineer. Other facilities such as an office, telephone, name board, survey equipment, etc. required for the Engineer, are described under the relevant sections.

PS 9 FEATURES REQUIRING SPECIAL ATTENTION

PS 9.1 CONTROL OF WATER

The Contractor is in all respects responsible for the handling of storm water from higher-laying areas, adjacent to the works for the handling of possible sub-surface water and for the handling of spoiled water when disconnecting existing connections or valves. No separate payment shall be made for this, as all costs related thereto shall be deemed to be included elsewhere in the tendered rates.

PS 9.2 "AS BUILT" DRAWINGS

As the work progresses, the Contractor shall keep full records of all amendments to and deviations from the drawings as issued to the Contractor at the start of the contract. The true positions, invert levels and ground levels of all services shall be indicated on the drawings, for which purpose the Contractor shall receive a separate complete set of drawings from the Engineer, at no cost.

The completion certificate shall only be issued after the Engineer has received a properly completed set of "AS-BUILT" drawings from the Contractor. No separate payment shall be made for this service, as all costs related thereto shall be deemed to be included in the related items.

PS 9.3 FINISHING AND TIDYING

Progressive and systematic finishing and tidying will form an essential part of this contract. Under no circumstances shall spoil, rubble, materials, equipment or unfinished operations be allowed to accumulate unnecessarily and in the event of this occurring the Engineer shall have the right to withhold payment for as long as necessary in respect of the relevant works in the area(s) concerned.

PS 9.4 SURVEY BEACONS

No separate payment shall be made for this, as all costs related thereto shall be deemed to be included elsewhere in the tendered rates.

PS 9.5 CONSTRUCTION MODUS OPERANDI

Labour-based or labour-intensive construction may be defined as the economically efficient employment of as much labour as is technically feasible to produce as high a standard of construction as demanded by the specification and allowed by the funding available. In other words, projects based on labour-intensive principles aim at devoting the highest feasible proportion of projects costs to unskilled, semi-skilled and skilled labour without jeopardising the technical quality of the product demanded by the specification.

The following regulations must be adhered to so as to ensure that the construction methods used are labour intensive.

- i) If not scheduled elsewhere otherwise the remuneration to local labour for hourly-rated employees and/or daily-based work shall be in accordance with the terms and conditions of Proclamation R1841 of Government Gazette 16833 dated 24 November 1995 or its latest amendment.
- ii) The name, identification number, task performed, and hours worked per day for each labourer shall be recorded by the Contractor. These records shall be submitted to the secretary of the Project Steering Committee on the second working day of each week following the recounted week.

The employment of local labour must be at least **6%**, if at all possible, of the total contract amount. The 6% must be divided as follows:

Percentage of labour	Description
55%	Women
55%	Youth (Above school, but under 36)
2%	Disabled persons

PS 9.6 LOCALLY BASED SUB-CONTRACTORS

Tenderers are encouraged to utilise the services of locally based sub-contractors.

PS 10 TRAINING

PS 10.1 General

A suitably capable Training consultant is to be employed on this project.

Their duty is to train the identified suitable persons for the following:

- i) Employee Training – community based labour
- ii) Employer Training – community based contractors
- iii) Committee Training – maintenance and operation of the Works (this however falls outside the scope of this Contract)

This project is a project using community-based labour and community based contractors as far as possible.

The Contractor using the necessary plant and labour as he sees fit shall carry out conventional construction. However, the Contractor may only bring in key staff from outside the area that has

the necessary skills not available among the local community. Other than key staff, all other labour must be employed from the local communities. As a guideline, key staff would include general foreman, foreman, site managers, buyers, quantity surveyors, etc.

The Training Consultant will provide the necessary training so that the local labourers will have the necessary skills to carry out this work. In this respect, the contractor and the Training Consultant will have to work closely together to identify what skills are required, how many labourers in each trade are required and when this labour will be required, so that the necessary training can be given timeously.

Typical training that is envisaged at this stage includes shuttering, concrete work, reinforcing, team leaders, etc. The other part of the Contract is work that will be carried out by community-based contractors.

The Training Consultant will identify persons, with the assistance of the Project Steering Committee, and train these persons to establish small community based contracting firms, who will employ local labour. These firms will tender to carry out this work and successful Tenderers will be appointed by the Contractor as nominated sub-contractors to execute this work.

Typical training that will be given by the Training Consultant is:

i) Community based contractors

- Preparation phase – using a calculator, numeracy, using a scale ruler, reading a building plan, handling administrative tasks in the building industry.
- Estimating and tendering – marketing the services of a company, seeking, selecting, collecting and studying tender documents, investigating and assessing a site, developing a bill of quantities from building plants, calculating the cost of a project, finalizing tender prices, completing and submitting a tender.
- Project planning – introducing to planning techniques, pre-tender planning, planning contract activities, contract planning, executing a contract programme.
- Executing the project – managing the finances of the company, managing materials, administering record systems, managing manpower, completion and handover.

ii) Community based labour

Local labour will be taught the following skills:

- Excavation if possible, bedding, selected backfill and backfill
- Pipe laying, valves and fittings
- Valve boxes, manholes, anchor blocks etc.

Again the Contractor and Training Consultant will have to work closely together to identify what their requirements are and when this labour is needed. Community based labour training will take place on site before actual production starts. No allowance needs to be made for wages, food or travelling during training. Training of community-based contractors will take place at a central point. The Provincial Sum allowed in the Schedule of Quantities, makes allowance for travelling and meals for the training of community based contractors.

PS 10.2 Construction and Materials Management

This section applies only to work to be carried out by community-based contractors. The contractor shall provide construction and material management to the community-based contractors. In this respect, each party has the following responsibilities.

i) Community Based Contractors

- To tender on the labour-based sub contract work and enter into a contract with the Contractor.
- To carry out the work according to specification and on time using community based labour.
- To liaise and co-operate with the contractor regarding specifications, programme, progress, delivery of material, quality of work etc.

- To provide wheelbarrows, hand tools, clothing, safety equipment, etc. to enable his labourers to carry out the work. All material (pipes, fittings, valves, etc.) to be provided by the Contractor.
- To receive material required for the task, store it and provide the necessary security until the material is built into the works.
- To provide the necessary transport for this labour force.
- To carry out a task in its entirety until final approval and acceptance. In other words there will be no split responsibility. For example a community based contractor will excavate, provide the bedding, selected backfill, backfill, lay pipes, valves and fittings, build valve boxes, manholes, anchor blocks etc. and test the pipes in conjunction with the Contractor.
- To pay his labourers. VAT etc. and finalize the final account.

ii) Contractor

- In conjunction with the Training Consultant, establish the needs, training and programming of the work.
- To assist the Training Consultant in drawing up the agreements of association between the Contractor and the community based contractors where applicable.
- To enter into nominated sub contracts with the community based contractors.
- To provide the necessary skills transfer and construction management for the community based contractors to successfully complete this work. This includes setting out of the work, quality control over the work, programming of the work, progress, testing and acceptance thereof.
- To provide the necessary materials to execute the work. This includes purchasing the required materials, transporting them to the camp site, storage at the campsite, transporting of materials as required from camp site to the sites of the various community based contractors, handling over of the materials.
- To pay the community based contractors as the work progresses and the Contractor must make allowance in his Tender for this. Retention monies will be as for this Contract. No sureties will be required from the community-based contractors.
- To measure the work and finalize the final account.
- Complete copies of the emerging contractor's contracts to be given to the Engineer for endorsement prior to the contract being signed.

Candidate selection would be according to the requirements for a particular discipline. A Certificate of Achievement should be awarded to a student who has attained a prescribed level of competency. A provisional amount for training has been recorded in both sections under the Item "Training", in the Preliminary and General portions in the Schedule of Quantities.

PS 11 APPLICABLE STANDARDISED SPECIFICATIONS

Although not bound in nor issued with this document, the following standardised specifications shall form part of the contract and, notwithstanding the provisions of sub clause 2.2 of SANS 1200 A, the editions specified below shall apply:

SANS 1200 A	-	1986	General
SANS 1200 C	-	1980	Site Clearance
SANS 1200 DB	-	1989	Earthworks (Pipe Trenches)
SANS 1200 GA	-	1980	Concrete (Small works)
SANS 1200 L	-	1983	Medium pressure pipe lines
SANS 1200 LB	-	1983	Bedding (Pipes)
SANS 1200 LF	-	1990	Erf Connection (Water)
SANS 1200 H	-	1990	Structural Steelwork (Tank)

PS 10.2 Particular Specification

PSVC : Pumps
PSPME : Ancillary work

The newest additions of above specifications up to and including the month of this tender will prevail.

PROJECT SPECIFICATION

PORTION 2: VARIATIONS AND ADDITIONS TO STANDARDISED SPECIFICATIONS

SANS 1200 A: GENERAL

PS A 3 MATERIALS

PS A 3.1 QUALITY

Substitute the second sentence of the first paragraph of A 3.1 with the following:

Materials shall bear the official mark of the appropriate standard.

Substitute the second paragraph with the following:

The Contractor is responsible for the cost of all testing to ascertain that the materials do comply with the relevant minimum requirements and all such costs shall be deemed to be included in the tendered rates. The cost of control tests done by the Engineer and of which the results do not comply with the minimum requirements shall be for the Contractor's account.

The Contractor shall inform the Engineer of any control testing to be done at least 48 hours before such tests are required and must allow in his program for the time necessary for the tests and the processing of the results thereof.

The handling, storage, transport, and erection of equipment, machinery, and materials shall be strictly in accordance with the requirements of the supplier and/or manufacturer.

All materials shall be new and of the best quality available unless otherwise specified. They must function satisfactorily under prevailing climate and weather conditions at the place of installations.

PS A 4 PLANT

PS A 4.2 Contractor's Offices, Stores and Resources

Add the following to A 4.2:

No housing is available for the contractor's employees and the contractor must make his own arrangements for accommodation and transport of his employees.

PS A 4.3 Hand Tools

The contractor shall provide and maintain all hand tools required for the execution of the Works.

PS A 5 CONSTRUCTION

PS A 5.1 SURVEY

PS A 5.1.1 Setting out of the Works

Substitute the first sentence in A 5.1.1 with the following:

Setting out of the works is the sole responsibility of the Contractor and shall be done from the layouts given to him. The proposed network pipes must be placed 2,0m away from the erf boundaries in the road reserve. Any discrepancy shall immediately be reported in writing to the Engineer. Any costs or subsequent costs arising from discrepancies, which had not been reported to the Engineer, shall be the sole responsibility of the Contractor. *The exact position of the network pipes shall be determined on site in conjunction with the Engineer and must be approved before construction of the specific section starts.*

The Engineer may alter any part of the works to suit local conditions. The Contractor must therefore contact the Engineer immediately after the preliminary setting out of any part of the works before starting with detail setting out, or construction. Only after the Engineer has approved a specific site or part of the works, may the detail setting out and construction commence.

PS A 5.2 WATCHING, BARRICADING, LIGHTING AND TRAFFIC CROSSINGS

Add the following to A 5.2:

The crossing of existing tar and dirt roads must be done in half widths, while the total traffic is accommodated on the other lane.

Road traffic signs shall comply with the requirements of the "South African Road Traffic Signs Manual" and shall be approved by the Engineer before construction commences.

PSA 7 TESTING

PS A 7.4 STATISTICAL ANALYSIS OF CONTROL TESTS

Substitute A 7.4 with the following:

Test results shall not be evaluated by statistical methods. All results shall comply with the specified minimum requirements of the materials concerned.

PS A 8 MEASUREMENT AND PAYMENT

PS A 8.2 PAYMENT

PS A 8.3 Fixed-Charge and Value-Related Items

PSA 8.3.1 Contractual Requirements..... Unit: Sum

The sum shall cover the Contractor's initial costs of providing sureties, insurance of the works and plant, third party or public liability insurance and unemployment insurance to cover his compliance with the requirements of the Workmen's Compensation Act, 1941 (Act NO. 30 of 1941) and any other initial financing obligations of a preliminary and general nature, such as contributions to the CEITB..

The tendered amounts for fixed-charge and value-related items will not be increased, if extension of time for the completion of the works is awarded.

PSA 8.3.2 Establishment of Facilities on the Site

PSA 8.3.2.1 Facilities for Engineer

- a) Furnished office (No) Unit: Sum
- b) Telephone (No) Unit: Sum
- c) Name board (1 No.) Unit: Sum

PSA 8.3.2.2 Facilities for Contractor

- a) Offices, and storage sheds Unit: Sum
- b) Workshops.....Unit: Sum
- c) Laboratories..... Unit: Sum
- d) Living Accommodation.....Unit: Sum
- e) Ablution and Latrine Facility..... Unit: Sum
- f) Tools and Equipment.....Unit: Sum
- g) Water Supplies, Electrical power and Communication..... Unit: Sum
- h) Dealing with water..... Unit: Sum
- i) AccessUnit: Sum
- j) PlantUnit: Sum

PSA 8.3.3 Other Fixed-Charge Obligations..... Unit: Sum

This item as listed under Schedule A of the bill of quantities is as specified in the standardised specification SANS 1200 A.

PSA 8.3.4 Removal of Site Establishment..... Unit: Sum

The sum shall cover the cost of the demolition on and the removal from the surface of the site of all items established in terms of 8.3.2 and 8.3.3, and shall provide for the making good and the restoring of the Site to the satisfaction of the Engineer

PSA B.8.3.5 OCCUPATIONAL HEALTH AND SAFETY

PSA B.8.3.5.1 Contractor’s initial obligations in respect of the Occupation Health and Safety Act and Contractual Regulations..... Unit: P/Sum

The full amount will be paid on the scheduled rate on condition that:

- (a) The contractor has notified the Provincial Director of the Department of Labour in writing of the project.
- (b) The contractor has made the required initial appointment of Employees and sub- contractors
- (c) The client has approved the contractor’s Health and safety plan
- (d) The contractor has set up his Health and safety File and Safety Plan.
- (e) The Contractor has appointed a Health and Safety officer.

The provincial sum shall represent full compensation for that part of the contractor’s general obligations in terms of Occupational Health and Safety Act and the Construction Regulation which are mainly a function of time. The sum for the supply of all safety equipment, safety clothing, first aid kit, etc. in order to adhere to the Occupational, Health and Safety Act specifications. The Contractor must familiarise himself with the conditions as per Occupational, Health and Safety Act and adhere thereto. The rate shall cover the Contractor’s overheads, charges, and profit on payments for the Service Provider. Contractor to note that this item covers the costs for the preparation and submission of Health and Safety plan and file.

Payment shall be as specified for item 1.3 in the standard specifications

PSA B.8.3.5.2 Occupational, Health and Safety Act..... Unit: %

Handling cost in respect of sub-item 8.3.5.1 A percentage of the payment made to the Occupational health and safety act will be paid to the Contractor under this section. The rate shall cover the Contractor’s overheads, charges, and profit on payments for the Occupational health and safety act.

(a) Provision for safety officer

The Contractor should appoint the safety officer who will be full time responsible for all safety issuers on site, and he or she should be full time on site.

The tendered rates include the full compensation for that part of the provision of safety officer in terms of the Occupational Health and Safety Act and the construction regulation which are mainly a function of time. Payment shall be made monthly.

- (a) Handling cost in respect of sub-item 8.3.5.2 (a). A percentage of the payment made to the Safety Officer will be paid to the Contractor. The rate shall cover the Contractor's overheads, charges, and profit on payments for the Safety Officer.

PSA B.8.3.5.3 Contractor's time related obligation in respect of the OH&S Act and Construction regulation

The tendered lump sum shall represent full compensation for that part of the contractor's general obligations in terms of Occupational Health and Safety Act and the Construction Regulations which are mainly a function of time. The lump sum will be paid monthly only after payment for item 1.3.3 and item 1.1.5 has been made Payment of the lump sum shall be made monthly (calculated by the division of the lump sum by the number of months remaining)

PS A 8.2.2 Time-Related Items

The tendered amount for a time-related item will be increased; if an extension of time for the completion of the works is awarded on the condition that the activity related to the item tendered for must be sustained during the extended period.

The ratio between the increased amount for a time-related item and the tendered amount must be the same as the ratio between the extension of the time period for the completion of the works and the original time period allowed for completion of the works.

If the works is completed before the end of the original time period allowed for completion of the works, the tendered amount of a time related item that is influenced by the earlier completion would be reduced similarly.

PS A 8.4 SCHEDULED TIME RELATED ITEMS

PSA 8.4.2.1 Facilities for Engineer

- a) Furnished offices Unit: Month
- b) Telephone for engineer's representative..... Unit: P/Sum

PSA 8.4.2.2 Facilities for Contractor.....Unit: Month

The sum shall cover the Contractor's initial costs of providing sureties, insurance of the works and plant, third party or public liability insurance and unemployment insurance to cover his compliance with the requirements of the Workmen's Compensation Act, 1941 (Act NO. 30 of 1941) and any other initial financing obligations of a preliminary and general nature, such as contributions to the CEITB. Establishment of Facilities on the Site Facilities for Engineer

- a) Offices, and storage sheds Unit: Month
- b) Workshops..... Unit: Month
- c) Laboratories..... Unit: Month
- d) Living Accommodation..... Unit: Month
- e) Ablution and Latrine Facility..... Unit: Month
- f) Tools and Equipment..... Unit: Month
- g) Water Supplies, Electrical power and Communication..... Unit: Month
- h) Dealing with water..... Unit: Month
- i) Access Unit: Month
- j) Plant Unit: Month

PSA 8.4.3 Supervision for Duration of Construction..... Unit: Month

The sum shall cover the costs of on-site supervision and such local administration as the Contractor considers necessary for the proper completion of the Works, and shall cover the cost of the salaries, wages and allowances paid to the site agent, general foreman, section foremen (where applicable), site surveyors, timekeepers, assistants and other site supervisory staff, and of transport incurred in connection with such staff. Plant (designated plant or plant for designated operations or plant for use during Supervision for Duration of Construction

PSA 8.4.4 Company and Head Office Overhead Cost/s for the Duration of the Contract.... Unit: Month

The sum shall cover the Contractor's company and head office overhead costs.

PS A 8.5 SUMS STATED PROVISIONALLY BY ENGINEER

PS A 8.5(a)1 Community Liaison Officer Unit : P/Sum

The Contractor must pay a salary to a person appointed as the Community Liaison Officer for the project. The amount of payment and payment dates will be determined as soon as the Community Liaison Officer is appointed. Proof of payment has to be submitted to Engineer before claim can be certified

PSA 8.5 (a) 2 PSC Meetings Attendance Unit: P/Sum

The tendered rate shall cover the compensation of all members of Project Steering Committee for attending meetings. The amount of payment and payment dates will be determined on the commencement date of the project. The Engineer should authorise payment before it is made. Proof of payment has to be submitted to Engineer before claim can be certified.

PS A 8.5(a)3 Overheads, charges and profit on (a)1 & 2 above Unit : %

Handling cost and profit in respect of sub-item 8.5(a)1&2. A percentage of the payment made to the Community Liaison Officer and PSC Meeting attendance will be paid to the contractor. The rate shall cover the Contractor's overheads, charges, and profit on payments for the Community Liaison Officer and PSC members. No payment will be made under this item before payment to the Community Liaison Officer and PSC members is made.

PS A 8.5(b)1 Training Unit : P/Sum

Provisional sum for training services supplied by the Training Company. The name and contact details of the Training Company, to be appointed by the Contractor, will be supplied to the Contractor by the Employer or Engineer.

PS A 8.5(b)2 Overheads, changes and profit on (b)1 above Unit : %

Handling cost and profit in respect of sub-item 8.5(b)1. A percentage of the payment made to the Training Company will be paid to the Contractor. The rate shall cover the Contractor's overheads, charges, and profit on payments for the Training Company. No payment will be made under this item before any payment is made to the Training Company.

PS C 8.5 EXISTING SERVICES

The services parallel to the pipeline routes must only be removed, repaired if damaged in a process and relocated to the positions as indicated and approved by the Engineer. When the pipeline routes cross fencing or gates temporary wire gates must be provided that must be kept closed. After completion of the work these fences or gates must be repaired to the same condition as before commencement of the work.

PS A 8.5(c)2 Overheads, changes and profit on (1) above

Unit : %

Handling cost in respect of sub-item 8.5(c)1. A percentage of the payment made to the Service Provider will be paid to the Contractor. The rate shall cover the contractor's overheads, charges, and profit on payments for the Service Provider.

PS A 8.7 DAYWORK

Replace A 8.7 with the following:

Day work will be paid according to the percentage allowance method. For calculating the total remuneration the General Conditions of Contract for Construction Works, Third Edition, 2015 shall apply, with the amendments as in the appropriate special conditions of contract, which is bound into this document. A day work schedule will be provided for filling in the necessary information.

A 8.8 TEMPORARY WORKS

PS A 8.8.2 Accommodation Of Traffic

Unit: Sum

Add the following to A 8.8.2:

The rate shall cover all costs pertaining to the provision, erection, moving, re-erection and maintenance of all temporary barricades, road signs, lights, flagmen, etc. as required, for the guarding and protection of the works, for the construction, gravelling and maintenance of access roads and detours to the site of the works, borrow pits or spoil sites, as well as for the later removal or the cleaning and tidying up thereof.

PROJECT SPECIFICATION

PORTION 2: VARIATIONS AND ADDITIONS TO STANDARDISED SPECIFICATIONS

SANS 1200 AB: ENGINEER'S OFFICE

PS AB 3 MATERIALS

PS AB 3.1 NAME BOARDS

Substitute "South African Institution of Civil Engineers" in the first paragraph of AB 3.1 with "South African Association of Consulting Engineers". Include the EPWP logo on the name board.

PS AB 3.2 OFFICEBUILDING

Replace AB 3.2 with the following:

Prior to commencing with work, the contractor shall provide and furnish for the use of the engineer's representative and his staff one office (3.0 x 4.5m Wendy House Type with veranda) in an approved position. The Engineer will indicate the position. All plans shall be submitted to the engineer for approval, before the commencement of erection.

The office with a minimum floor area of 13.50m² (the smaller dimension at least 3.0m) with a ceiling height of minimum 2.1m, shall also have one toilet apart from the office building for the exclusive use of the engineer's representative.

The office shall be provided with lined walls and boarded ceilings and floor and suitable door with secure locks. The office shall be ventilated, weather proof and waterproof and shall have windows with an area to at least 20% of the floor area. The office shall be insulated to provide comfortable working conditions.

Internal furnishings shall include:

- One desk (1,5m long x 1,0m wide x 0,9m high) with lockable drawers with keys
- One drawing table
- Eight desk chairs
- One table (2,0m long x 1,0m wide x 0,9m high) with smooth top.

PS AB 4 PLANT

PS AB 4.1 TELEPHONE AND FAX

Replace AB 4.1 with the following:

The Contractor shall supply the Engineer with a cellular telephone service for the exclusive use of the Engineer and Engineers Representative for official purposes for the duration of the contract.

PS AB 5 CONSTRUCTION

PS AB 5.1 NAME BOARDS

Add the following to AB 5.1:

The name boards shall be erected within a month of the commencement date of the contract and shall be placed at the position indicated by the Engineer. Any damage to these boards shall be repaired within seven days of a written instruction issued by the Engineer. No payment shall be made in terms of the contract prior to the erection of the name boards.

The Contractor will be permitted to erect a maximum of two of his own name boards, in positions approved by the Engineer. The Engineer reserves the right to order the removal of these boards if they are not kept in good repair.

PS AB 5.5 SURVEY ASSISTANTS

Substitute "two or more suitably educated survey labourers" in the first sentence of PS 5.5 with "two semi-skilled labourers."

PS AB 5.6 SURVEY EQUIPMENT

The Contractor shall provide the following tested and approved survey equipment on site for the duration of the contract and for the use of the Engineer whenever needed:

- a) one tachometer capable of reading to minimum 20 seconds and maximum 6 seconds of arc, plus tripod;
- b) one automatic level plus tripod;
- c) two tachometer staffs and one level staff, all graduated metrically;
- d) one 5m and one 100 m tape measure; and
- e) diverse surveyors necessities like paint, pegs, etc.

The above-mentioned equipment may by arrangement be shared between the Contractor and the Engineer's representative.

The Contractor shall keep the equipment continuously insured against any loss, damage, or breakage, and he shall indemnify the Engineer and the Employer against any claims in this regard.

The Contractor shall maintain the equipment in good working order and keep it clean throughout the contract period.

PS AB 8 MEASUREMENT AND PAYMENT

PS AB 8.2 PAYMENT

PSAB 8.2.2(a) Office buildings Unit: Sum

The rate shall cover all time-related costs pertaining to the office building as prescribed in PS AB 3.2.

PSAB 8.2.2(b) Telephone and fax Unit: Sum

The rate shall cover all time-related costs pertaining to the telephone and fax as prescribed in PS AB 4.1.

PS AB 8.2.2(c) Name board (1 off) Unit: Sum

The rate shall cover all time-related costs pertaining to the name board/s as prescribed in PS AB 5.1.

PSAB 8.2.2(d) Survey assistance and equipment Unit: Sum

The rate shall cover all time-related costs pertaining to the survey assistants and equipment as prescribed in PS AB 5.6.

PROJECT SPECIFICATION

PORTION 2: VARIATIONS AND ADDITIONS TO STANDARDISED SPECIFICATIONS

SANS 1200 C: SITE CLEARANCE

PS C 3 MATERIAL

PS C 3.1 DISPOSAL OF MATERIAL

Substitute the first sentence of C 3.1 with the following:

Material obtained from clearing and grubbing shall be disposed of at the site indicated at the site inspection. If such a site is indicated at tender stage, the cost of transporting material and debris will be included under 8.2.1.

Loading and off-loading should be done by hand and the contractor must price accordingly under item 8.2.1.

PS C 5 CONSTRUCTION

PS C 5.1 AREAS TO BE CLEARED AND GRUBBED

Substitute the first sentence of C 5.1 with the following:

Unless otherwise indicated by the Engineer, clearing and grubbing are limited to a 2,5m wide strip along the pipe route. Measurement and payment for clearing and grubbing shall only occur for areas as required in writing by the Engineer.

The Contractor may proceed with clearing and grubbing after the handing over of the site.

PS C 5.2 CUTTING OF TREES

PS C 5.2.3 Preservation of Trees

PS C 5.2.3.2 Individual trees

Add the following to C 5.2.3.2:

Trees outside pipeline routes must be left standing and undamaged, except where otherwise ordered in writing by the Engineer.

A penalty of **R15 000,00** per tree for trees damaged and/or removed will be charged.

PSC 5.3 EXISTING FENCING

The fencing parallel to the pipeline routes must only be removed and re-erected at the positions as indicated and approved by the Engineer and repaired where it was damaged. When the pipeline routes cross fencing or gates temporary wire gates must be provided that must be kept closed. After completion of the work these fences or gates must be repaired to the same condition as before commencement of the work.

PS C 8 MEASUREMENT AND PAYMENT

PS C 8.2 SCHEDULED ITEMS

PS C 8.2.1 Clear and grub (1.0m wide) Unit: m

The removal of all rocks and boulders on site over 0,15 m³ will be paid under sub clause D 8.3.2(b). The removal of hard rock other than boulders will be paid under sub clause PS DB 8.3.2(b).

PSC 8.2.2 Remove and grub large trees and tree stumps of girth

- a) over 1 m and up to and including 2 m Unit: No
- b) over 2 m and up to and including 3 m Unit: No

The girth of a tree or stump will be measured at the narrowest point of the tree or stump in the first metre of its height above ground level. Trees and stumps of girth exceeding 1 m will be measured individually and classified according to site in increments of 1 m as indicated above.

The rate shall cover the cost of clearing and grubbing trees and stumps of all sizes, cutting branches, backfilling holes, and removing, transporting, and disposing of all such trees, stumps, and branches and associated material.

PSC 8.2.3 Remove and grub all trees and tree stumps regardless of girth Unit: No

In exceptional circumstances, where construction is carried out through plantations or where the quantity of trees or girth exceeding 1 m renders individual measurement impracticable the project specification may provide that the clearing and grubbing of trees be measured in hectares. If this method of measurement is used the areas to which it is applicable will be defined clearly on the drawings and the reason for adopting the method of measurement will be stated in the project specification.
The rate shall cover the cost of all operations specified in .8.2.2.

PSC 8.2.5 Take down existing fence..... Unit: m

The rate shall cover the cost of taking down the fences, coiling wire, sorting and stacking all material at sites indicated by the Engineer and the cost of loading, transporting and offloading such material.

The rate shall cover the cost of reinstating fence to original condition on completion of all scheduled work

PROJECT SPECIFICATION

PORTION 2: VARIATIONS AND ADDITIONS TO STANDARDISED SPECIFICATIONS

SANS 1200 DB: EARTHWORKS (PIPE TRENCHES)

PSDB 1 SCOPE

This specification covers earthworks for trenches for all types and sizes of pipes. It covers excavation, the preparation of a trench bottom, backfilling and the reinstatement of surfaces.

PS DB 3 MATERIALS

PS DB 3.1 CLASSIFICATION FOR EXCAVATION PURPOSES

PS DB 3.1.1 Method of Classifying

Substitute DB 3.1.1 and DB 3.1.2(a), (b) and (c) with the following:

The Engineer shall classify excavated materials as Soft Class and Rock. Rock will be measured individually as extra-over items.

TABLE 1 : CLASSIFICATION OF MATERIALS

CLASSIFICATION	DESCRIPTION
Soft	All material other than rock
Rock	Material which cannot be economically fragmented and loosened for removal by hand implements and pneumatic tools, except by drilling and blasting or the use of rock breaking equipment.

TABLE 1.1

	NUMBER OF BLOWS REQUIRED FOR A DCP PENETRATION OF 100mm	
	GRANULAR SOIL	COHESIVE SOIL
SOFT - Class 1	≤ 2	≤ 1
SOFT - Class 2	> 2, ≤ 6	> 1, ≤ 5
SOFT - Class 3	> 7, ≤ 5	> 5, ≤ 8
INTERMEDIATE	> 15, ≤ 50	> 8,
HARD	> 50	-

In the first instance, the classification shall be based on the descriptions given in Table 1. In the event of disagreement between the Contractor and the Engineer, the Engineer shall reclassify the material in accordance with relevant specifications and without being unreasonable to the Contractor. The decision of the Engineer on the classification shall then, subject to the provisions of the Contract, be final and binding.

The Contractor shall notify the Engineer of the presence of what he considers to be rock immediately upon discovery thereof. The Engineer will inspect the material and decide whether or not it warrants the use of pneumatic tools or rock breaking equipment. In the case of isolated boulders set in a soil matrix, the Engineer may order the Contractor to either widen the excavation or roll the boulders sideways or lift the boulders out from the trenches.

In the event that the Engineer decides that the use of pneumatic tools, rock breaking equipment, or blasting is necessary, he will classify the material accordingly and arrange for the quantity thereof to be measured. The Construction Manager will supply necessary pneumatic equipment and arrange for others to break up rock into manageable pieces.

PS DB 3.5 BACKFILL MATERIALS

- a) Substitute "from trenches" in DB 3.5(a) with "from trenches and street excavations".

Add the following to DB 3.5(b):

- c) Road crossings, access to services, farms and camps and any section that fall within the road reserve shall be classified as areas subject to loads from road traffic and must be compacted accordingly to the top of the trench (natural ground level).

PS DB 3.7 SELECTION OF MATERIAL FOR REPAIR WORK

If the excavation of a pipeline damages an existing road surface, the Contractor must stockpile material from the top 200mm of such a road surface in order to reuse it as sub base for the repairing of the road crossing.

If necessary gravel material that is suitable for the reparation of road surfaces must be imported.

The Contractor must make provision in his tariffs for compaction in road reserves for the selection of excavated material as specified above.

PS DB 4 PLANT

PS DB 4.1 EXCAVATION EQUIPMENT

Add the following to DB 4.1:

An adequate number of suitable tools, including hand stampers, wheelbarrows and hosepipes shall be provided by the Contractor. The Contractor will supply mechanical compaction equipment and when required pneumatic and rock breaking equipment.

All excavations exceeding the specified widths shall be backfilled with approved selected material. No payment shall be made for this and all relevant costs shall be deemed to be included in the tendered rates.

PSDB 5 CONSTRUCTION

PSDB 5.1 PRECAUTIONS

PS DB 5.1.1.1 Water in Trenches

Water in pipe trenches may cause movement of the pipes as a result of flotation and backfilling must therefore be executed as quickly as possible. If movement of the pipes does occur the contractor must, unless otherwise instructed by the Engineer, remove the pipes from the trench and reinstall it at his own expense.

PS DB 5.4 EXCAVATION

Add the following to DB 5.4:

"Excavation and backfilling of pipe trenches on sidewalks in the residential area shall be done in such a manner as to ensure the least possible disruption to the public and access to the properties. No additional payment shall be made for this and all relevant costs shall be deemed to be included in the tendered rates.

PS DB 5.5 TRENCH BOTTOM

Substitute "90 %" in the second paragraph of DB 5.5 with "93 %".

PS DB 5.5.1 Over Excavation of Trenches

Where pipe trenches are excavated deeper than specified or shown on the drawings, these excavations must be backfilled with suitable approved selected material in layers of not more than 150mm uncompacted thickness and must be compacted to the thickness of the adjoining in-situ material or as prescribed by the Engineer.

PS DB 5.6 BACKFILLING

PS DB 5.6.1 General

Backfilling in road reserves must be compacted in 100mm layers up to natural ground level.

Where prescribed by the Engineer all surplus material must be neatly piled over the real trench width to a height not more than 150mm higher than the adjoining level.

PS DB 5.6.3 Disposal of Soft Excavation Material

Add the following to DB 5.6.3:

All surplus and unsuitable material as described in DB 5.6.3 shall be disposed of at the spoil site, (as described in PS D 5.2.2.3) and levelled.

PS DB 5.7 COMPACTION

PS DB 5.7.2 Areas Subject To Traffic Loads

Add the following to DB 5.7.2:

All pipe trenches within road crossings, accesses to services, farms and camps that fall within the road reserve, will be regarded as areas subject to traffic loads. Backfilling of trenches that are subject to traffic loads will be executed in layers of 100mm as follows:

Item	% mod AASHTO	Final Layer Thickness
Approved Backfill	93%	200mm
Main Backfill up to road layers	96%	200mm
Sub-base	97%	200mm
Base	98%	175mm

PS DB 5.9 REINSTATEMENT OF SURFACE

PS DB 5.9.2 Private Property and Commonage

Add the following to DB 5.9.2:

Gardens and lawns shall be repaired to the original standard where they were crossed. Grass and plants shall be taken out of the ground, temporarily stocked, watered during construction, and replanted after backfilling.

PSDB 8 MEASUREMENT AND PAYMENT

PSDB 8.2 COMPUTATION OF QUANTITIES

PS DB 8.2.4 Shoring

Add the following to DB 8.2.4:

Shoring will only be measured and paid for, if the Engineer gives written approval before it is installed.

PSDB 8.3.2 Excavation

(a) Excavation in all material for trenches, backfill, compact and dispose of surplus material..... Unit (m)

Item will be provided for various pipe diameters in steps not greater than those specified in 5.2 and various depths in increments of 1.0 m measured to the bottom of the bedding layer (see Drawing DB 2, DB 3, and DB 4). Where measured volumetrically in terms of 8.1.2 (a), the volume of excavation will be computed in accordance with 8.2.2 and 8.2.3

The rate shall cover the cost of the same operation in heading where the Contractor elects to use such a method of excavation. The volume or length will be measured for payment on the assumption that normal trench excavation has been carried out. The volume or length in the undisturbed prism of material between the top of the tunnel and ground level will be classified as soft excavation in terms of 3.1. No additional payment will be made for such headings and no deductions will be made for reduced excavation quantities.

(b) Extra-over item (a) above for:

- 1. Intermediate excavation Unit: m³
- 2. Hard rock excavation..... Unit: m³
- 3. Hand excavation and backfill where ordered by the engineer. Unit: m³
- 4. Soil Crete backfilling where directed by the engineer. Unit: m³

Separate items will not be provided for depth increment, volume will be computed from the trench width determined in accordance with 8.2.3 and the depth from the top of the intermediate or hard rock excavation, as the case may be, either to the bottom of the same material or to the bottom of the trench as specified in (a) above, whichever is the lesser (see Drawing DB 5)

The rates shall cover the additional cost of the excavation and hauling of the more difficult material of unsuitable material.

c) Excavate and dispose of unsuitable material from trench bottom (provisional)... Unit: m³

The volume will be computed from the trench width determined in accordance with 8.2.3 and m³ the additional depth ordered.

The rate shall cover the cost of the excavation of the additional depth in any material, the disposal of the unsuitable material as specified for soft: excavation in 5.6.3 within free haul distance and the backfilling of the additional depth with suitable material from the side of the trench.

PSLF 8.17 GENERIC LABOUR-INTENSIVE SPECIFICATION

The Generic Labour-intensive specification below is the same as SANS 1921-5, Construction and management requirement for works contracts- Part 5:

PSDB 8.3.3 EXCAVATION ANCILLARIES

PSDB 8.3.3.1 Make up deficiency in backfill material

- a) from other necessary excavations on site Unit: m³
- b) by importation from-designated borrow pits Unit: m³
- c) by importation from commercial or off-site sources selected by the Contractor Unit: m³

Items (b) and (c) above will not be measured for payment unless importation has been ordered in writing. The volume will be computed from the trench width determined in accordance with 8.2.3 and the depth from the top of the backfill to the top of the bedding as shown on Drawing DB-1 or the actual depth of backfill used to make up the deficiency or the depth of additional excavation ordered in terms of B.3.2(c), as applicable.

The rate for material from other necessary excavations on site shall cover the cost of selection of suitable material, the moving of the material to points alongside the trench spaced to suit the Contractor's method of working, and the disposal of the material that is replaced, all within free haul distance.

The rate for material from designated borrow pits shall cover the cost of royalties, if applicable, excavation and selection of suitable material, the moving of the material to points alongside the trench spaced to suit the Contractor's methods of working, and the disposal of the material that becomes surplus as a result of the importation, all within free haul distance.

The rate for material from commercial or off-site sources selected by the Contractor shall cover the cost of the acquisition of the material (including royalties, if applicable), the moving of the material to points alongside the trench spaced to suit the Contractor's methods of working, and the disposal of the material that becomes surplus as a result of the importation, all within free haul distance (see Sub clause 5.2.5.1 of SANS 1200 D or Sub clause 5.2.6.1 of SANS 1200 DA, as applicable).

PSDB8.3.3.2 Opening up and closing down of designated borrow pitUnit: Sum

This item will only be scheduled when a new borrow pit has to be established or when access to an existing borrow pit has to be established.

With the exception of the cost of the removal and spreading back of the topsoil (if scheduled), the sum shall cover the cost of opening up and of restoring the Site as specified in Sub clause 5.2.2.2 of SANS 1200 D or Sub clause 5.2.2(f) of SANS 1200 DA, as applicable.

PSDB 8.3.5 Existing Services

Existing Services-that Intersect or Adjoin a Pipe Trench (see Sub-clauses 5.1.2 and 8.3.8 of SANS 1200 D or Sub-clauses 5.1.3 and 8.3.5 of SANS 1200 DA, as applicable.)
(See Sub clauses 5.1.2 as applicable.)

- (a) Services that intersect a trench (angles between centre-lines in plan of 45-90°)..unit (No)

Except where water pipes are to be recovered, existing water pipes, sewers, storm water pipes, concrete-lined channels and drains, box culverts, electric cables, ducts, kerbs, channels, erf connections and various sizes of pipes and services that intersect a trench of specified width and require various degrees of care, whether or not their presence is known before they are uncovered, will be measured separately. The unit refers to one service, but services that are so grouped that they can be contained within a horizontal dimension of 200 mm measured at right angles to the axis of the services will be measured as one unit.

- (b) Services that adjoin a trench (parallel to or at an angle between centre-lines in plan of less than 45°)..... Unit. (No)

In a case where a trench of specified width

1 runs parallel to or at an angle (in plan) of less than 45° to an existing service, and is such that the nearer side of the bottom of the trench lies at least partly between a vertical plane and a plane that lies at an angle of 45° below the horizontal, both planes passing through the axis of the service, the length of service within the minimum base width of the trench, determined in accordance with 5.2, will be measured for payment under this item and the remaining length, the side of the trench which, in the opinion of the Engineer, is rendered liable to collapse because of the existence of such service, will be measured for shoring (see 8.3.4(a)).

The rate for an item scheduled in terms of (a) and (b) above shall cover the additional cost of

- i) care in excavation necessitated by the presence of such service in or across the trench;
- ii) Protecting and maintaining such service in operation by means of temporary supports or shoring, as necessary;
- iii) Delays and disruption of the progress of the work due to the existence of the service¹ and
- iv) Repairs necessitated by damage caused by the Contractor.

PS DB 8.3.6 Finishing

PS DB 8.3.6.1 Reinstate road surfaces complete with all courses

Unit: m²

Replace DB 8.3.6.1 with the following:

- a) Gravel

Unit: m²

The area will be calculated from the length of finished road or paved surfaces as applicable and with the trench width taken as 0,8m. Payment for finishing will be additional to that for excavation covered by 8.3.2.

The rate shall cover the cost, selective excavation (including the equipment that is required to break up, remove and, if necessary, stockpile the original surface material), and subsequently of reinstating and compaction and shall include the cost of delays and the cost of any risk of having to repair damage as specified in DB 5.10. Compaction to be according to PS DB 5.7.2

PROJECT SPECIFICATIONS

PORTION 2: VARIATIONS AND ADDITIONS TO STANDARDISED SPECIFICATIONS

SANS 1200 GA: CONCRETE (SMALL WORKS)

PSG1 SCOPE

This specification covers the requirements for concrete (plain and reinforced) for small works associated with pipelines, roads, railways, pump stations, etc. It covers the basic materials, the plant and formwork required, the quality, manufacture, and curing of concrete, tolerances in workmanship, testing, and the methods by which the finished structure is to be measured for the purposes of payment

PSGA 3 MATERIAL

PSGA 3.2.1 Applicable Specifications

Add the following to G 3.2.1:

Portland cement that conforms to SANS 471

PSGA 3.2.2 Storage of Cement

Add the following to G 3.2.2:

Consignments of cement shall be used in the same sequence as that in which they are delivered to site. No cement shall be used which has been stored on site for a longer period than 6 (six) weeks. All cement so stored for a longer period than 6 (six) weeks, all cement damaged in any way, and all cement which does not comply with the specification, shall be removed immediately and permanently from the site.

PSGA 4 PLANT

PSGA 4.4 Formwork

PSGA 4.3.3 Ties

Add the following to G 4.4.3:

No ties will be allowed in vertical walls and permanent metal ties shall have a minimum concrete cover of 40 mm. Tie holes shall be filled with an approved non-shrink epoxy grout.

PSGA 5 CONSTRUCTION

PSGA 5.1 REINFORCEMENT

PSGA 5.1.3 Cover

Substitute G 5.1.3 with the following:

The cover of concrete over reinforcement, unless otherwise indicated on the drawings, shall be not less than 40 mm.

PSGA 5.2 FORMWORK

PSGA 5.2.1 Classification of Finishes

Add the following to G 5.2.1:

The following surface conditions are required in the various portions of the finished concrete:

(a) **Rough**

Concealed surfaces and surfaces lower than 100 mm below finished ground level.

(b) **Smooth**

All surface finishes not classified as "rough" in paragraph (a) shall be classified as "smooth". All exposed edges unless otherwise indicated on the drawings, shall be chamfered 20 mm x 20 mm by means of triangular fillets fixed to the formwork.

PSGA 5.4 CONCRETE

PSGA 5.4.1 Quality

PSGA 5.4.1.2 Consistency

Add the following to sub clause G 5.5.1.2(a):

The slump of concrete used in water retaining structures may not be less than 30mm and not more than 60mm.

PSGA 5.4.1.5 Strength concrete

Add the following to G 5.5.1.7:

The grade of strength concrete and the maximum nominal size of coarse aggregate for each portion of the works, unless otherwise indicated on the drawings, shall be as follows:

(a) Blinding layers and encasing of pipes	20 MPa/50 mm
(b) Benching	20 MPa/19 mm
(c) Screeds	20 MPa/13.5 mm
(d) Reinforced concrete	40 MPa/19 mm

PSGA 5.4.1.7 Durability

Concrete shall be so proportioned to ensure that the water/cement ratio does not exceed 0,5 and, to ensure workability, water-reducing admixtures of approved manufacture shall be used in preference to increasing the cement content.

PSGA 5.4.8 Concrete Surfaces

Add the following to GA 5.4.8.1:

Concrete surfaces under screeds, granolithic finishes or benching shall be brought up to a plane, uniform surface with a suitable screed board.

PSGA 5.4.11 Construction Joints

The use of construction joints must be minimised and may only be placed as shown on the drawings or at positions as approved by the Engineer.

At all construction joints in walls a PVC water stop without a centre bulb must be placed as shown on the drawings.

Alternative materials with similar properties may be proposed but may only be installed after approval of the Engineer.

PSGA 5.5.10.4 Wood-floated finish

Where wood floating is specified or scheduled, the surface shall first be given a finish as specified in G 5.5.10.1 and after the concrete has hardened sufficiently; it shall be floated to a uniform surface free from trowel marks. The screed surface shall be wood-floated, either by hand or machine, only sufficiently to produce a uniform surface free from screed marks.

PSGA 5.5.10.5 Steel-floated finish

Where steel floating is specified or scheduled, the surface shall be treated as specified in PS G 5.5.10.4 except that, when the moisture film has disappeared and the concrete has hardened sufficiently to prevent laitance from being worked to the surface, the screed surface shall be steel-trowelled under firm pressure to produce a dense, smooth, uniform surface free from trowel marks.

PSGA 8 Measurements and Payment

PSGA 8.1.1 Formwork

Formwork, other than formwork covered by 8.1.1.2 and 8.1.4, will be measured as the net area of the face of the concrete to be supported during the deposition of concrete. No deduction will be made for fillets and splays of size up to 50 mm x 50 mm or for openings of diameter up to 0,7 m or of area up to 0.5 m².

Formwork in continuous lengths of narrow widths and of fillets or splays over 20 mm x 20 mm will be measured by length, the width or range of widths being stated in the schedule. Boxing-out, the forming of holes, and other such operations will be measured by number, basic dimensions, perimeters, or drawing references, as stated in the schedule.

The unit rate shall cover the cost of all parts of formwork in contact with the concrete, and the necessary bearers, struts, and other supports, plus the labour and plant necessary to erect and strike such formwork.

PSGA 8.1.2 Reinforcement

Steel for normal reinforced concrete will be measured net by mass of all bars, including supporting steel detailed on the reinforcing schedules. The mass will be computed from the nominal bar size and nominal mass per unit length. No allowance will be made for cutting, waste, spacer devices (materials other than steel bars), or binding wire.

Steel reinforcement for precast concrete units will not be measured unless so scheduled (see 8.6).

Welded mesh will be measured by area as shown on the drawings, No allowance being made for cutting, waste, laps, or deductions for end cover. The areas measured will be those of the concrete floor or slab being reinforced by means of mesh. In the case of continuous unit partly reinforced by mesh, the area will be computed from the outside dimensions of the area covered by mesh regardless of whether or not additional reinforcing steel is present in the same area.

Steel off cuts resulting from the cutting and bending of reinforcement in accordance with the bending schedules shall be deemed to be the property of the Contractor.

PSGA 8.1.3 Concrete

a) Concrete will be measured net to the dimensions shown on the drawings or to the dimensions cast, whichever are the smaller. Structural elements that are undersized will be measured for payment only if they are accepted by the Engineer

b) No allowance will be made for concrete required to make up over break in soft excavation, but payment will be made for additional concrete or formwork, or both, ordered in writing by

the Engineer to replace unsuitable material or over break in hard rock or in intermediate excavation.

The unit rates shall cover the cost of the provision of concrete (made with ordinary Portland cement unless otherwise scheduled), mixing, testing, placing, compacting, the forming of stop-ends and unforeseen construction joints, striking of for levelling as applicable, and curing and repairing where necessary, together with the cost of all parts of formwork in contact with the concrete and the necessary bearers, struts, and other supports, plus the layout and plant necessary to erect and strike such formwork.

PROJECT SPECIFICATION

PORTION 2: VARIATIONS AND ADDITIONS TO STANDARDISED SPECIFICATIONS

SANS 1200 LB: BEDDING (PIPES)

PS LB 1 SCOPE

PS LB 1.1 SCOPE

Add the following to LB 1.1:

This specification also covers the bedding required for sleeve pipes.

PS LB 3 MATERIALS

PS LB 3.1 SELECTED GRANULAR MATERIAL

Substitute LB 3.1 with the following:

Selected granular material shall be an aggregate, sand or granular material, all of a non-cohesive nature and free from any organic material, of which the grading analysis shows 100 % passing a 13, 2 mm sieve and not more than 5 % passing a 0,075 mm sieve.

Only if approved by the Engineer may sand from the trench excavations be used as selected material.

PS LB 3.2 SELECTED FILL MATERIAL

Substitute LB 3.2 with the following:

The requirements of PS LB 3.1 shall apply *mutatis mutandis*.

PS LB 3.3 BEDDING

Add the following to LB 3.3:

All pipes shall be classified as flexible pipes and shall have a bedding of selected granular material and selected fill material.

PS LB 3.4 SELECTION

PS LB 3.4.1 Suitable Material from Trench Excavation Available

Replace the first sentence of LB 3.4.1 with the following:

Notwithstanding the requirements DB 3.7 and LB 3.4.1 relating selected excavation methods, the Contractor must follow selected excavation methods and provide or use plant that will prevent material that is suitable and necessary for bedding being contaminated.

PS LB 5 CONSTRUCTION

PS LB 5.1 GENERAL

PS LB 5.1.4 Compacting

Substitute "90 % of Mod. AASHTO" in LB 5.1.4 with "93 % of Mod. AASHTO."

If sand is used the compaction grade must be 100% Mod. AASHTO

PS LB 8 MEASUREMENT AND PAYMENT

PS LB 8.1 PRINCIPLES

PSLB 8.1.1 Provision of Bedding from Trench Excavation

a) Selected granular materialUnit: m³

b) Selected fill material.....Unit: m

The rates shall cover the cost of acquiring, from within 1 km, bedding that complies with the relevant requirements of the specification, of delivering it to points alongside the trench spaced to suit the Contractor's methods of working, and of disposing of displaced material within a free haul distance of 1 km.

In terms of the standardized specifications covering pipelines, the rate for the supply and laying of pipelines covers the cost of handling bedding material from alongside the trench and placing it under and around the pipeline.

PSLB 8.1.2 Supply only of Bedding by Importation

From other necessary excavations

a) Selected granular materialUnit: m³

b) Selected fill material Unit: m³

PSLB 8.1.4 From commercial sources

a) Selected granular material Unit: m³

b) Selected fill material Unit: m³

The rate shall cover the cost of acquiring, regardless of distance, the required bedding from commercial sources (see Sub clause 8.3.4 of SANS 1200 D or Sub clause 8.3.4 of SANS 1200 DA, as relevant), of delivering it to points alongside the trench spaced to suit the Contractor's methods of working, and of delivering it to points alongside the trench spaced to suit the Contractor's methods of working, and of disposing of material displaced by such importation, within a free haul distance of 0,5 km.

PSLB 8.1.6 Encasing of Pipes in Concrete Unit: m³

Separate items will be scheduled for each size of pipe and for each grade of concrete specified.

The volume will be computed from the dimensions of the concrete as given on the drawing.

The rate shall cover the cost of dealing with any excavation (in all materials including disposal of surplus) that is additional to that measured under the item for pipe trench excavation, the cost of encasing the pipe in concrete including the cost of formwork (if any), etc., and the cost of formwork to form flexible joints at 4 m centres.

The rate shall cover encasement of pipe through stream crossings, Rate shall include formwork, mixing and placing of concrete (5m³) and Gabions (10m³).

PS LB 8.2.5 Overhaul of material for Bedding cradle and selected fill blanket

Unit: m³.km

Substitute LB 8.2.5 with the following:

- a) Limited overhaul (0,5 km to 1,0 km) Unit: m³
- b) Long overhaulUnit: m³.km

Except that the volume is calculated according to LB 8.1.3, the requirements of D 8.3.6 or DA 8.3.3, as applicable, shall apply for overhaul.

PROJECT SPECIFICATION

PORTION 2: VARIATIONS AND ADDITIONS TO STANDARDISED SPECIFICATIONS

SANS 1200 L: MEDIUM PRESSURE PIPELINES

PSL 1 SCOPE

This specification covers the supply and installation of pipelines of diameter up to 1 000 mm, Complete with ancillary works, for transporting water and sewage under working pressures of up to 2.5 MPa.

PSL 3 MATERIAL

PSL 3.1 GENERAL

Replace the first sentence of L 3.1 with the following:

Duraflow mPVC and uPVC pipes, where relevant, will be used in the water pipelines.

Pipes and fittings shall be of the types specified in the schedule or in the project specification and, unless otherwise required in terms of the project specification, they and their couplings shall be capable of withstanding the applicable test pressure specified in 7.3.1. All pipes and fittings shall be supplied complete with couplings and jointing material.

Satisfactory temporary end covers shall be provided for the protection of threads, flanges, and prepared ends of plain-ended pipes and fittings, and to prevent damage to internal lining during transportation and during handling on Site.

Pipeline materials shall be so transported, stored, and handled that pipes are not overstressed at any time and fittings are not damaged in any way. PVC pipes to be stored under shade for the period between delivery to site and pipe laying and backfilling. All thin-walled, flexible, and soft-coated pipes shall be handled with particular care and shall be so stored that they are not subject to concentrated pressure from stones or other objects. Pipes damaged or cracked in any way shall be removed from the Site.

PSL 3.9 CORROSION PROTECTION

PSL 3.9.2 Protection of Steel Pipes and Accessories

All the pipe items of steel with diameters from 100mm and more must, unless otherwise specified be provided of three coats of epoxy paint (KSIR 88 or similar) to provide a final film of 300 micron dried thickness. Application must be according to the suppliers' prescription and must be on the inside and outside. Steel pipe items with diameters smaller than 100mm must be protected using galvanising or epoxy paint.

PSL 3.10 VALVES

All valves must be painted according to an approved method with epoxy paint (KSIR 88 or similar), to provide a final film of 300 micron dried thickness, after manufacturing and testing. Complete technical information of all valves must be submitted to the Engineer for approval before purchase.

PSL 3.10.1 Gate Valves

All gate valves shall be of the AVK type, shall comply with the requirements of SANS 664 and shall be suitable for a working pressure of 1, 6 MPa (Class 16), or as indicated on the detail drawings. All gate valves must be supplied with a square spindle nut, suitable to be used with a valve key, or with a hand wheel as indicated on the detailed drawings. One valve key per nut size must be provided and will be included in the rate for valves.

All gate valves shall be flanged and drilled according to SANS 1123 or B.S. 4504 Table 16, unless shown differently on the drawings, and shall be right hand closing. The direction for opening and closing shall be permanently displayed on the valves. Valves shall have non-rising spindles.

Compression shut-off valves with rubber protected gate and smooth finish without recess inside, may be used.

The spindle seal shall consist of at least two O-rings located in a corrosion resistant housing. A wiper ring to prevent ingress of dirt shall be provided. The spindle nut may be loose or fixed in the gate.

The valves shall be provided with a straight, unobstructed body passage without any pocket and the gate shall be completely clear of the waterway in the fully open position. The sealing and gate guide areas shall be designed to eliminate deposits in the valve body. The gate guides shall be of substantial design to support the gate until the point of closure.

All components shall be interchangeable between valves of one size.

The rated working pressure shall be as detailed on the drawings. The valves are required to seal drop tight from zero to a test pressure of 1,1 times the rated working pressure under test and field conditions.

The valve shall be capable of being opened and closed under an unbalanced pressure equal to the rated working pressure.

Pipes shall not be tested against a closed valve. Thrust blocks for test sections shall be approved by the Engineer prior to testing of pipes.

PSL 3.10.2 Air Valves

All air valves to be Double orifice type. Rate shall include all accessories required as per tender drawing.

PSL 5 CONSTRUCTION

PSL 5.1 LAYING

PSL 5.1.1 General

Where connecting to the existing pipeline the position of the existing pipeline must be established by excavating test holes (hand excavation) before any trench excavation to the planned connection point is undertaken. The Contractor will not be compensated for excavation and any other work that is executed and proves to be unnecessary because this specification was not followed.

PSL 5.4 CONCRETE ENCASING

Replace the first sentence of L 5.4 with the following:

Concrete encasing with concrete with strength of 20 MPa/19mm, must be provided at positions indicated by the Engineer. Provision must be made to keep the pipe in position during the placement of the concrete encasing. The length of concrete encasing will be determined by means of site instructions from the Engineer.

PSL 5.4.1 Soil Crete Encasing

Add the following:

A mixture of Portland cement and gravel of base quality that is mixed in a ratio of 1:10 must be provided at positions indicated by the Engineer. Provision must be made to keep the pipe in position during the placement of the soilcrete encasing. The length of soilcrete encasing will be determined by means of a site instruction from the Engineer.

PSL 5.5 ANCHOR BLOCKS

Delete “15 Mpa/37,5mm” in the second sentence and replace with “20Mpa/19mm”

PSL 5.6 VALVE CHAMBERS

PSL 5.6.1 General

Substitute the first sentence of L 5.6.1 with the following:

The drawings of valve chambers, which are bound into the document, shall supersede the corresponding drawings in the standard specification.

Valve chambers, to the relevant specified sizes and specifications, shall be installed at all the new positions as indicated on the detailed drawings.

PSL 5.10 CLEANING OF PIPE

Sub clauses (a), (b) and (c) must be adhered to.

PSL 5.11 PIPE MARKERS

Pipe markers shall be installed at 50m intervals on the pipeline route, at all the newly installed isolation and scour valves as indicated on the detailed drawings as well as at all positions where the pipeline route deviates from the horizontal.

PSL 7 TESTING

PSL 7.3 STANDARD HYDRAULIC PIPE TEST

PSL 7.3.1 Test pressure and time of test

Add the following to L 7.3.1.1:

Pipes shall not be tested against isolating valves. Special blank flanges or end caps, fully anchored, shall be provided for testing.

PSL 8 MEASUREMENT AND PAYMENT

PSL 8.2 SCHEDULED ITEMS

PSL 8.2.1 Supply, Lay and Bed Pipes complete with couplingsUnit: m

PSL 8.2.1.1 uPVC Class 9, 12 and 16 Pipes

The pipes should be the type with a spigot at one end and a socket with lying rubber at the other. Contractor has an option to supply mPVC piping of same class and diameter if he so wishes, on condition the rate of cost used is that of uPVC. All pipes to have the class and diameter clearly marked, in addition to Manufacturer’s details.

PSL 8.2.1.2 Steel Pipes

The pipes should be threaded at both ends and supplied fitted with one threaded socket. The pipes will thus be jointed using threaded sockets except on advice of Engineer or where drawings details indicate otherwise.

PSL 8.2.2 Extra-over 8.2.1 for the Supplying, Laying, and Bedding of Specials Complete with CouplingsUnit: No

These shall be measured and paid for per installation, complete with the inclusion of the cutting of pipes, couplings, extra excavation and all extra material and labour that is required, including tees, fittings complete as shown on the drawings.

PSL 8.2.2.1 Extra-over 8.2.1.1 for the Supplying, Laying, and Bedding of Specials Complete with Couplings for Steel pipes and adaptors to PVC

Bends, Tees and Reducers shall be steel, be flanged and drilled to Table 16 at all ends. End caps to be flanged at the open end. Bends to be long radius. Steel - uPVC Adaptors to be flanged at end linking to the steel pipe and spigot ended at end linking the PVC pipe. The spigot end to match the diameter of PVC piping. Separate flanges to be drilled to Table 16 with threading to match the steel pipe threading.

PSL 8.2.2.2 Extra-over 8.2.1.2 for the Supplying, Laying, and Bedding of Specials Complete with Couplings for uPVC pipes

All bends, reducers, tees, end caps etc for uPVC sections to be uPVC, unless indicated on the drawings. All bends to be long radius with one end socketed and the other spigot end. The rest of the fittings/ specials to be socketed at all ends, unless the drawings or Engineer suggests otherwise.

PSL 8.2.3 Extra-over 8.2.1 for the Supply, Fixing and Bedding of Valves Unit: No

Add the following to L 8.2.3:

Valves are measured and paid for per installation, complete with the inclusion of the cutting of pipes, couplings, extra excavation and all extra material and labour that is required, including tees, fittings complete as shown on the drawings.

PSL 8.2.4 Cut Into and Connect To Existing Mains Unit: No

The number of each type and diameter of pipe cut into shall measure the cutting into existing mains.
The Tendered rate shall include full compensation for all arrangements with the relevant authorities, isolating the main, cutting into the main to accommodate the connecting fitting, dewatering, excavating, removing of excess material, taking steps to prevent the ingress of soil, stones and other material into the main as well as all material and labour to connect the pipe.

PS L 3.10 VALVES

PS L 3.10.1 Gate Valves

(a) 200mm isolation valve..... unit (No.)

All gate valves shall comply with the requirements of SANS 664 – Figure 2 and shall be suitable for a working pressure of 1.0 MPa. All gate valves shall be supplied with hand wheels, unless shown otherwise on the drawings.

Gate valves shall have flanged ends unless shown otherwise on the drawings and shall open clockwise. The direction for opening and closing shall be permanently displayed on the valves. Valves shall have non-rising spindles.

Spindles, spindle nuts, gate rings and body rings shall all be of bronze.

All flanged gate valves shall be drilled according to SANS 1123 Table 1600/3.

PSL8.2.10 Temporary Valves,

Payment for the supply or loan of temporary valves, end caps, blank flanges, or other isolating devices ordered by the Engineer in terms of 7.3.1.1 will be made at daywork rates or at a price to be agreed by the Engineer, unless the method of payment for the work has been dealt with in the project specification and a suitable item included in the schedule.

PSL 8.2.11 Anchor/Thrust Blocks

Unit: m³

Substitute L 8.2.11 with the following:

Anchor and thrust blocks shall be measured per cubic metre concrete and the Tendered rate shall include for all formwork and reinforcement (where specified) for the required dimensions.

“The concrete will be measured net by volume to the specified width and depth in excess of the external volume of the pipe (i.e. the volume of the pipe will be deducted).

The rate shall cover the cost of formwork and concrete.”

PSL 8.2.13 VALVE CHAMBERS

Valve and hydrant chambers, manholes, etc., will be measured as complete units.

The rate shall cover additional excavation (see Sub clauses 8.2.2 and 8.2.3 of SANS 1200 LIB), materials, plant, and labour necessary for the complete construction including the installation of the surface boxes or covers.

Valve chambers will be measured and paid for by number and the tariff must include all excavation, installation, finishing and numbering of the chamber, all materials as well as labour as described in PSL 5.12.

PSL 8.2.17 Soil Crete Casing

Unit: m³

The soil Crete (1:10 ratio) is measured by volume according to the specified width and depth that exceeds the outside volume of the pipe (the volume of the pipe detracted).

The tariff includes the cost of shuttering and soil Crete mixture.

PSL 8.2.18 Pipe Markers

Unit: No

Pipe markers will be measured and paid for by number and the tariff must include all excavation, installation, and paint and numbering of marker, concrete as well as labour as described in PS L 5.11.

PROJECT SPECIFICATION

**PORTION 2: VARIATIONS AND ADDITIONS TO
STANDARDISED SPECIFICATIONS**

SANS 1200 VC: FENCING

PSVC 1 SCOPE

This specification covers the erection of a new 2.4m high fence with 1 x motor gate 4.5m x 2.4m.

PSVC 4.2 SECURITY FENCING

Add this item to cover the erection of a new 2.4m high fence

PSVC 4.2.1 Material

(a) Straining posts, stays, standards and droppers

Straining posts, stays, standards and droppers shall be of the type and size indicated on the drawings. Steel sections shall comply with the requirements of CKS 82 and timber posts with the requirements of SANS 457, Timber posts shall be treated with a preservative in accordance with the requirement of sub clause 5402 (b)(i)

Droppers shall be 0.56 kg/m ridgeback pattern droppers

Tubular straining posts and stays shall be galvanized in accordance with SANS 763 for class B1 articles, or shall be painted as specified in section 8400 as may be required on the drawings, and shall have a wall thickness of at least 2.95 mm. Unless otherwise shown on the drawing, all tubular posts shall be provided with a 230 mm x 230 mm footplate and a pressed steel or cast-iron cap. Tubular stays shall have a nominal bore of at least 60 mm.

Rolled steel section shall be provided with a protective coating of tar or other approved material.

(b) Bolts for stays

Bolts shall be galvanized steel bolts of the required length and a diameter which shall not be less than 12 mm. All the necessary bolts, nuts and washers, shall be supplied with each post.

B 5507 Erecting fence wire

All fence wire shall be tied to the sides of standards or posts to prevent the wires from being displaced or becoming loose. The wire shall be carefully tensioned without sagging and true to line, care being exercised not to tension the wire to such an extent that it will break, or that end, corner, straining or gate posts will be pulled out or that it will be easily damaged during veld fires.

Each strand of fencing wire shall be securely tied in the correct position hard up to each standard with soft galvanized tying wire. The tying wire for each strand shall pass through a hole or notch in the standard, while the ends of the tying wire shall be wound at least four times around the fencing wire to prevent it from moving in a vertical direction

B 5513 GENERAL REQUIREMENTS

The completed fence shall be plumb, taut, true to line and ground contour, with all posts, standards and stays firmly set. The height of the lower fencing wire above the ground at posts and standards shall not deviate by more than 25 mm from that shown on the drawings. Other fencing wires shall not deviate by more than 10 mm from their prescribed vertical positions.

B 5514 MEASUREMENT AND PAYMENT

Item	Unit
55.01 Cleaning the fence line 2 m wide strip.....	m(m)

The removal of trees and stumps with a girth exceeding 1 m shall be paid as specified in section 1700

B 55.02 Supply and erect new fencing material for new fence and for supplementing material in existing fences which are being repaired or removed:

- (a) Zinc-coating barbed wire 3 mild steel grade, double stand 2.5 mm diameter unidirectional twist(SANS 675).....m (m)

- (b) Zinc-coating smooth wire 2.24mm diameter. high tensile fencing wire(SANS 675).....m (m)

The unit of measurement shall be erected as specified in the drawings completely drilled with steel cap and base plate and painted. The price shall also include full compensation for the excavation of 300mm x 300mm x 800mm deep holes and the backfill with concrete.

Gate

Single motor gate (4.5m x 2.4 mm)Unit (No.)

The unit of measurement shall be the number of new gate erected. The two wings of the double gates shall be considered as one gate. The tendered rate shall include full compensation for the procurement and supply of all material including gates, gate posts, hinges, bolts, mesh, binding wire, concrete, etc., as well as the erection of the gates as specified and indicated on the drawings.

**PROJECT SPECIFICATION
PORTION 2: VARIATIONS AND ADDITIONS TO
STANDARDISED SPECIFICATIONS**

PSH STRUCTURAL STEEL: SANS 1200 H

CONTENTS

**PSH1: MATERIALS
PSH 2: CONSTRUCTION
PSH 3: FABRICATION**

PSH 4: MEASUREMENT AND PAYMENT

PSH 1: MATERIALS

The materials specifications shall apply to pressed steel tanks, including any tank support structures, supplied and installed under this contract.

PSH 2: CONSTRUCTION

Detail design drawings and specifications shall be prepared by the tank supplier and provided to the Engineer prior to the procurement of pressed steel tanks. Detail design drawings and specifications for the support frame structure for elevated steel tanks shall also be provided to the Engineer, where applicable.

The supplier is responsible for shop drawings for steel tanks and support frame structure. The supplier shall also provide design certificates to the Engineer prior to procurement.

PSH 3: FABRICATION

The fabrication specifications shall apply to pressed steel tanks, including any tank support structures, supplied and installed under this contract.

**PSH 4: MEASUREMENT AND PAYMENT
PRE-FABRICATED PRESSED STEEL TANK:**

PSH 8.3.1 Elevated Pressed Steel Reservoir: Unit: Sum

The materials, design, fabrication and testing shall be in accordance with SANS 1200 H and these variations to the standard specifications.

The rate shall provide for all labour, plant, equipment and incidental costs to supply and erect the pressed steel tank complete for operation. The rate shall include all support frames and structures, concrete foundations and any other work required to complete the supply and erection of the tank. The rate shall also include for the supply of detail design drawings, shop drawings, test certificates and engineering design certificates to the Engineer.

**PROJECT SPECIFICATION
PORTION 2: VARIATIONS AND ADDITIONS TO
STANDARDISED SPECIFICATIONS**

SANS 1200 VC:WATER PUMPS PROJECT SPECIFICATIONS

PSVC WATER PUMPS

CONTENTS

- PSVC 1: SCOPE
- PSVC 2: GENERAL
- PSVC 3: MATERIALS AND WORKMANSHIP
- PSVC 4: INSTALLATION

PSVC 1: SCOPE

This specification covers the design, manufacture, supply, delivery and testing of water pumps such as used for pumping water from dams and reservoirs, and as in line booster pumps.

PSVC 2: GENERAL

Pumps shall be of the maker's standard and approved design, capable of performing the required duty at a preferred speed of 1500 RPM. Pumps shall be supplied complete with motor, drives, couplings and base plate or frame. Pipes, pipe fittings, valves etc are specified and scheduled elsewhere. All electrical switchgear, cabling etc shall be supplied as stated in the project specification. The design of the pump/motor set shall be of the non-overloading type to prevent failure of the motor should the delivery pipeline fail.

The duty required of the pump is described in terms of the system curves in this document and pumps supplied shall be capable of successfully performing under all conditions so indicated. As far as possible, standard component parts shall be used.

PSVC 3: MATERIALS AND WORKMANSHIP

The Contractor shall ensure that materials, seals, bearings and couplings are correctly chosen in compliance with the original design requirements. Where substitution to suit local (as opposed to overseas) conditions and availability of materials is required, the Engineer shall be advised in writing, together with the motivation for the substitution. The calculations and specifications for the original design and the proposed substitutions shall be made available to the Engineer.

PSVC 3.1: CASINGS:

Pump casings shall be of high grade cast iron designed to be capable of pressures 40% greater than the shut off head of the pump.

PSVC 3.2: BEARINGS:

All bearings shall have a minimum design life given by a B10 rating of 30,000 hrs. Adequate attention to choice of bearings shall be made in respect of loading, thrust, mounting, thermal expansion and contraction, lubrication and the conditions under which the bearings will be operating.

PSVC 3.3: IMPELLERS:

Impellers shall be made of cast iron, cast steel zinc free bronze or stainless steel. For fractional kW pumps other materials may be considered but used only with the Engineer's approval. The impeller shall be securely fixed to the shaft with a key and keyway and blind nut.

PSVC 3.4: WEARING RINGS:

Where pumps are fitted with wearing rings to limit recirculation losses they shall be machined to tolerances compatible with the solids content of the water to be pumped.

PSVC 3.5: SEALS:

Pumps shall be fitted with stuffing boxes rather than mechanical seals under most conditions for ease and simplicity of maintenance.

Seals shall be effective over the normal working range ie no flow static head to shut off head of pump. Leakage from glands shall be openly collected and suitably piped out of the pump station.

a). Stuffing Boxes:

Stuffing boxes shall be sized as to accommodate not less than four rings of packing plus the lantern ring and a portion of the gland. The lantern ring shall be served by both inlet and outlet connections. A renewable sleeve shall be fitted to the shaft where it passes through the stuffing box. A slinger shall be incorporated between the stuffing box and the bearings. The stuffing box shall be easily tightened, and removed for repacking.

b). Mechanical Seals:

Particular attention shall be paid to the selection of materials and design of the seal in relation to the conditions under which the pump is to operate.

PSVC 3.6: MOUNTINGS AND BASEPLATE:

The pump shall be suitably equipped with mounting points to facilitate location and fixing in position the pump to a baseplate or flange mounting. In mounting to the baseplate or frame, which shall also serve the prime mover and gearbox, facility shall be provided for setting up and alignment.

The baseplate shall be manufactured from steel and be of sufficient stiffness to ensure location and alignment within acceptable tolerances.

The baseplate shall be securely bolted to the floor or foundation block with at least M20 bolts, before final alignment and setting up of the pump/drive/motor.

PSVC 3.7: PIPE WORK AND FITTINGS:

PSVC 3.7.1: General:

The pipework associated with the pumps shall be supplied and installed by the Contractor to ensure the proper functioning of the installation.

Where specified, all pipework, reflux valves, puddle flanges, bends and specials shall conform to the following:

SANS 509 and 546:	Cast iron and cast steel fittings.
SANS 719 and 720:	Mild steel pipes and fittings.
SANS 286, 721 and 946:	Asbestos cement pipes and fittings.
SANS 121:	Galvanized iron pipes and fittings.
SANS 966:	Un-plasticised polyvinyl chloride pipes and fittings.
SANS 533:	High density Polyethylene pipes and fittings.
BS 3605:	Stainless Steel.
SANS 664:	Sluice Valves.

The pipework shall be designed by the Contractor to suit the characteristics of the pumps supplied, and in addition shall be sized so that the velocity in the suction pipework shall not exceed 1,5 m/sec whilst the velocity in the delivery pipework shall not exceed 2,5 m/sec.

PSVC 3.7.2: Pipes:

The class of pipe selected shall be such as to provide a working pressure equal to the greater of:

- a). Maximum shut off head of the pumps, or
- b). The pressure given in the project specifications which allows for working head and pressure surges, or
- c). For cast iron pipes Class B - BS 2035.
- d). For spun cast iron Class B - BS 1211.
- e). For steel, Grade A, SANS 719/71, manufactured to dimensions given in BS 534/1966, minimum test pressure of 1,5 x a) or b) above, whichever is the greater, subject to a minimum wall thickness of 6 mm.

PSVC 3.7.3: Pipe Joints:

Generally, flanged joints are required. Where required for movement or assembly and maintenance requirements Viking Johnson couplings shall be used.

Flanges shall be manufactured in accordance with SANS 1123 as amended, and the pressure requirements of the adjacent pipework. Each joint shall be completely watertight under test and working conditions.

PSVC 3.7.4: Valves:

Each pump shall be fitted with an isolating valve on both the suction and delivery pipes, and a non-return valve shall be installed adjacent to the pump on the delivery side.

PSVC 3.7.5: Gate Valves:

Gate valves shall be manufactured to the requirements of SANS 665. All valves shall close on clockwise rotation of the hand-wheel. The hand-wheel shall be clearly and permanently marked with "open" and "shut" with arrows indicating the direction of rotation. All valves shall be capable of being opened and closed by one man against the maximum differential pressure.

PSVC 3.7.6: Butterfly Valves:

Butterfly valves may be used only on "clear water" ie water containing no particles or stringy matter which would affect the operation of the valves.

All valves shall be capable of being opened and closed by one man against maximum differential pressure.

PSVC 3.7.7: Non-return valves:

Non-return valves shall be suitable for use in either horizontal or vertical mounting. They shall be so designed and manufactured so as to provide satisfactory operation under the conditions of service envisaged and under zero flow conditions. Access to moving parts shall be possible without the need to remove the body from the line.

PSVC 3.8: PRESSURE GAUGES:

Each pump shall be fitted with suitable pressure gauges on both the suction side and the delivery side of the pump. The gauges shall be permanently mounted in position and provided with an isolation valve.

Gauges shall be a diameter of not less than 100 mm and shall be calibrated to indicate at least 5%. An accuracy of within 1% or better is required.

PSVC 3.9: MOTOR-PUMP COUPLINGS AND TRANSMISSIONS:

Generally the pump shall run at the same speed as the prime mover and be directly coupled by means of a flexible coupling. Where such a layout is not desirable vee-belt drives are preferred, and only under exceptional circumstances will the use of a gearbox be approved.

The flexible coupling or vee-belt drive, where used, shall be designed to accept the full load torque at design speed, and also the start and stop loads, with due allowance being made for shock loading.

The couplings or drive shall also be designed to accommodate under all the above loading conditions, thermal expansion and contraction movements of the shafts, the effects of end float, vibrations and a practical amount of misalignment of the shafts.

PSVC 3.10: SHAFTS:

The installation shall comply with the requirements of the Machinery and Occupational Safety Act NO 6 of 1983 as amended.

All rotating or moving parts shall be enclosed by moveable guards.

PSVC 3.11: PAINTING AND CORROSION PROTECTION:

Where possible, materials of manufacture shall be selected for corrosion resistant properties.

Detailed requirements for painting and corrosion protection are specified in a separate section.

PSVC 3.12: NAMEPLATES:

A corrosion resistant nameplate shall be fixed to the pump with the following information punched or engraved thereon;

- Manufacturer's name.
- Serial number of the pump.
- Model number and type.
- Impeller type/diameter installed.
- Normal operating head and flow.
- Rotational speed.
- Bearing numbers.
- Lubricant type.

PSVC 3.13: MOTORS:

The electric motor shall be a direct coupled 220/380 V 50 Hz 3 phase motor which is capable of operating continuously under the load requirements specified without stalling or being overloaded.

The motor shall comply with the relevant section of BS 2613 or BS 170 where applicable. The motor shall be so sealed from the pump as to prevent the ingress of moisture and shall have a completely moisture proof terminal block into which the power supply cable is to be brought.

PSVC 4: INSTALLATION

PSVC 4.1 PUMPS:

The pump and motor set, mounted on common base plate or frame, shall be fixed onto a removable trolley, to the Contractor's requirements.

PSVC 4.2 PIPEWORK AND FITTINGS:

Erection of pipework and position of fittings shall be carried out in such a way as to ensure the minimum of residual stress in the installation. Great care shall be taken both in the design and protection of the pipework to ensure that no undue forces are imposed on the pump itself. The Contractor shall be responsible for the positioning, design and implementation of all pipe supports. After the pumps have been in operation for about a week the foundation bolts shall be finally tested for tightness, the alignment checked, and dowel pins fitted in the pump and motor feet.

PSVC 4.3 TESTING:

All pumps shall be subject to a site test, as installed, to confirm the performance of the equipment supplied against the data supplied at time of tender. Under certain circumstances, pumps may also be tested in the manufacturer's works before installation.

All performance testing shall be carried out in accordance with BS 5316 Part 1 Class C, with all instrumentation and personnel being supplied by the Contractor.

The tests shall be carried out after initial installation checks and after at least 12 hours of test running. Should any aspects of performance not fall within 5% of the stated figures supplied at time of tender, the Contractor shall take all necessary steps to correct the performance and the tests shall be performed again.

On completion of each test the results shall be made available to the Engineer.

Pumping equipment, valves and fittings shall be measured and paid for by lump sum and shall be held to include the supply, installation, testing and commissioning of all pumps including all fixing bolts and brackets and all work necessary to ensure satisfactory operation of the pumping installation.

PSB- 10 MEASUREMENTS AND PAYMENT

PSB- 10.6 Supply, delivery, installation, commissioning and maintenance (during defect liability period) Borehole equipment, this includes Borehole positive displacement pump complete with pump head, electrical motor, suitable columns and stabilizers, switch box and gear (Pump depth = 54m, flow = 12.0 l/s).....Unit: No

PSB- 10.8 Supply, delivery, installation, commissioning and maintenance (during defect liability period) Borehole equipment, this includes Borehole positive displacement pump complete with pump head, electrical motor, suitable columns and stabilizers, switch box and gear (Pump depth = 40m, flow = 5.0 l/s).....Unit: No

PSVC- 10.5 Testing of pumps

(a) Complete workshop testing a specified, for each pump-set as scheduled in item PMB -10.2Unit: No



CAPRICORN DISTRICT MUNICIPALITY

C6. OHS Specifications for construction projects

5.1 Specification

1. PREAMBLE

In terms of Construction Regulation 4(1)(a) of the Occupational Health and Safety Act, 1993 (Act 85 of 1993), the Capricorn District Municipality, as the Client, shall be responsible to prepare Health & Safety Specifications for any intended construction project and provide any Principal Contractor who is making a bid or appointed to perform construction work for the Client on its behalf with the same.

The Client's further duties are as described in The Act and the Regulations made there-under. The Principal Contractor shall be responsible for the Health & Safety Policy for the site in terms of Section 7 of the Act and in line with Construction Regulation 5 as well as the Health and Safety Plan for the project.

This 'Health and Safety Specifications' document is governed by the "Occupational Health and Safety Act, 1993 (Act No. 85 of 1993), hereinafter referred to as 'The Act'. Notwithstanding this, cognisance should be taken of the fact that no single Act or its set of Regulations can be read in isolation. Furthermore, although the definition of Health and Safety Specifications stipulates 'a documented specification of all health and safety requirements pertaining to associated works on a construction site, so as to ensure the health and safety of persons', it is required that the entire scope of the Labour legislation, including the Basic Conditions of Employment Act be considered as part of the legal compliance system. With reference to this specification document this requirement is limited to all health, safety and environmental issues pertaining to the site of the project as referred to here-in. Despite the foregoing it is reiterated that environmental management shall receive due attention.

Due to the wide scope and definition of construction work, every construction activity and site will be different, and circumstances and conditions may change even on a daily basis. Therefore, due caution is to be taken by the Principal Contractor when drafting the Health and Safety Plan based on these Health and Safety Specifications. Prior to drafting the Health and Safety Plan, and in consideration of the information contained here-in, the contractor shall set up a Risk Assessment Program to identify and determine the scope and details of any risk associated with any hazard at the construction site, in order to identify the steps needed to be taken to remove, reduce or control such hazard. *This Risk Assessment and the steps identified will be the basis or point of departure for the Health and Safety Plan.* The Health and Safety Plan shall include documented 'Methods of Statement' (see definitions under Construction Regulations) detailing the key activities to be performed in order to reduce as far as practicable, the hazards identified in the Risk Assessment.

2. SCOPE OF HEALTH AND SAFETY SPECIFICATION

The Health and Safety Specifications pertaining to this project; cover the subjects contained in the index and is intended to outline the normal as well as any special requirements of the Client pertaining to the health and safety matters (including the environment) applicable to the project in question. These Specifications should be read in conjunction with the Act, the Construction Regulations and all other Regulations and Safety Standards which were or will be promulgated under the Act or incorporated into the Act and be in force or come into force during the effective duration of the project. The stipulations in this specification, as well as those contained in all other documentation pertaining to the project, including contract documentation and technical specifications shall not be interpreted, in any way whatsoever, to countermand or nullify any stipulation of the Act, Regulations and Safety Standards which are promulgated under, or incorporated into the Act.

3. PURPOSE

The Client is obligated to implement measures to ensure the health and safety of all people and properties affected under its custodianship or contractual commitments, and is further obligated to monitor that these measures are structured and applied according to the requirements of these Health and Safety Specifications.

The purpose of this specification document is to provide the relevant Principal Contractor with any information other than the standard conditions pertaining to construction sites which might affect the health and safety of persons at work and the health and safety of persons in connection with the use of plant and machinery; and to protect persons other than persons at work against hazards to health and safety arising out of or in connection with the activities of persons at work during the carrying out of construction work for the Capricorn District Municipality. The Principal Contractor is to be briefed on the significant health and safety aspects of the project and to be provided with information and requirements on inter alia:

- a) Safety considerations affecting the site of the project and its environment;
- b) Health and safety aspects of the associated structures and equipment;
- c) Submissions on health and safety matters required from the Principal Contractor and,
- d) The Principal Contractor's health & safety plan.

To serve to ensure that the Principal Contractor is fully aware of what is expected from him/her with regard to the Occupational Health and Safety Act, 1993 (Act No. 85 of 1993) and the Regulations made there-under including the applicable safety standards, and in particular in terms of Section 8 of the Act.

To inform the Principal Contractor that the Occupational Health and Safety Act, 1993 (Act 85 of 1993) in its entirety shall apply to the contract to which this specification document applies. The Construction Regulations shall apply to any person involved in construction work pertaining to this project, as will the Act.

4. DEFINITIONS

"Purpose of the Act" –

To provide for the health and safety of persons at work and the health and safety of persons in connection with the use of plant and machinery; the protection of persons other than persons at work against hazards to health and safety arising out of or in connection with the activities of persons at work; to establish an advisory council for occupational health and safety; and to provide for matters connected therewith.

"Agent" –

Means any person who acts as a representative for a client;

"Client" –

Means any person for whom construction work is performed;

"Construction Work" is defined as any work in connection with –

- (a) the erection, maintenance, alteration, renovation, repair, demolition or dismantling of or addition to a building or any similar structure;
- (b) the installation, erection, dismantling or maintenance of a fixed plant where such work includes the risk of a person falling;
- (c) the construction, maintenance, demolition or dismantling of any bridge, dam, canal, road, railway, runway, sewer or water reticulation system or any similar civil engineering structure; or
- (d) the moving of earth, clearing of land, the making of an excavation, piling, or any similar type of work;

“Contractor” –

Means an employer, as defined in Section 1 of the Act, who performs construction work and includes Principal Contractors;

“Health and Safety File” –

Means a file, or other record in permanent form, containing the information required a contemplated in the regulations;

“Health and Safety Plan” –

Means a documented plan which addresses hazards identified and includes safe work procedures to mitigate, reduce or control the hazards identified;

“Health and Safety Specification” –

Means a documented specification of all health and safety requirements pertaining to the associated works on a construction site, so as to ensure the health and safety of persons;

“Method Statement” –

Means a document detailing the key activities to be performed in order to reduce as reasonably as practicable the hazards identified in any risk assessment;

“Principal Contractor” –

means an employer, as defined in section 1 of the Act who performs construction work and is appointed by the client to be in overall control and management of a part of or the whole of a construction site;

“Risk Assessment” –

Means a program to determine any risk associated with any hazard at a construction site, in order to identify the steps needed to be taken to remove, reduce or control such hazard.

5. OCCUPATIONAL HEALTH & SAFETY MANAGEMENT

5.1 Structure and Organisation of OH&S Responsibilities

5.1.1. Overall Supervision and Responsibility for OH&S

- The Client and/or its Agent on its behalf to ensure that the Principal Contractor, appointed in terms of Construction Regulation 4(1)(c), implements and maintains the agreed and approved H&S Plan. Failure on the part of the Client or Agent to comply with this requirement will not relieve the Principal Contractor from any one or more of his/her duties under the Act and Regulations.
- The Chief Executive Officer of the Principal Contractor in terms of Section 16 (1) of the Act to ensure that the Employer (as defined in the Act) complies with the Act.
- All OH&S Act (85 /1993), Section 16 (2) appointee/s as detailed in his/her/their respective appointment forms to regularly, in writing, report to their principals on matters of health and safety per routine and ad hoc inspections and on any deviations as soon as observed, regardless of whether the observation was made during any routine or ad hoc inspection and to ensure that the reports are made available to the principal Contractor to become part of site records (Health & Safety File).
- The Construction Supervisor and Assistant Construction Supervisor/s appointed in terms of Construction Regulation 6 to regularly, in writing, report to their principals on matters of health and safety per routine and ad hoc inspections and on any deviations as soon as observed, regardless of whether the observation was made during any routine or ad hoc inspection and to ensure that the reports are made available to the principal Contractor to become part of site records (Health & Safety File).
- All Health and Safety Representatives (SHE-Reps) shall act and report as per Section 18 of the Act.

5.1.2. Legal Appointments

Several appointments or designations of responsible and /or competent people in specific areas of construction work are required by the Act and Regulations. The following competent appointments, where applicable, in terms of the Construction Regulations are required to ensure compliance to the Act, Regulations and Safety Standards.

Required appointments as per the Construction Regulations:-

Item	Regulation	Appointment	Responsible Person
1.	4(1)(c)	Principal contractor for each phase or project	Client
2.	5.(3)(b)	Contractor	Principal Contractor
3.	5(11)	Contractor	Contractor
4.	6(1)	Construction supervisor	Contractor
5.	6(2)	Construction supervisor sub-ordinates	Contractor
6.	6(6)	Construction Safety Officer	Contractor
7.	7(1)	Person to carry out risk assessment	Contractor
8.	7(4)	Trainer/Instructor	Contractor

Item	Regulation	Appointment	Responsible Person
9.	8(1)(a)	Fall protection planner	Contractor
10.	10 (a)	Formwork & support work supervisor	Contractor
11.	10(e) + (f)	Formwork & support work examiner	Contractor
12.	11(1)	Excavation supervisor	Contractor
13.	11(3)(b)(ii)(b)	Professional engineer or technologist	Contractor
14.	11(3)(k)	Explosives expert	Contractor
15.	12(1)	Supervisor demolition work	Contractor
16.	12(2) + (3)	Demolition expert	Contractor
17.	12(11)	Explosives expert	Contractor
18.	14(2)	Scaffold supervisor	Contractor
19.	15(1)	Suspended platform supervisor	Contractor
20.	15(2)(c)	Compliance plan developer	Contractor
21.	15(8)(c)	Suspended platform expert	Contractor
22.	15(13)	Outrigger expert	Contractor
23.	17(8)(a)	Material hoist inspector	Contractor
24.	18(1)	Batch plant supervisor	Contractor
25.	18(7)	Batch plant operator	Contractor
26.	19(2)(b)	Power tool expert	Contractor
27.	19.2 (g) (i)	Power tool controller	Contractor
28.	20(f)	Tower crane operator	Contractor
29.	21(1)(d)(i)	Construction vehicle and mobile plant operator	Contractor
30.	21(1)(j)	Construction vehicle and mobile plant inspector	Contractor
31.	22(d)	Temporary electrical installations inspector	Contractor
32.	22 (e)	Temporary electrical installations controller	Contractor
33.	26 (a)	Stacking and storage supervisor	Contractor
34.	27 (h)	Fire equipment inspector	Contractor

This list may be used as a reference or tool to determine which components of the Act and Regulations would be applicable to a particular site. This list must not be assumed to be exclusive or comprehensive.

5.2 Communication & Liaison

- 5.2.1 OH&S Liaison between the Employer, the Principal Contractor, the other Contractors, the Designer and other concerned parties shall be through the project Committee as per the procedures determined by the project Committee.
- 5.2.2 In addition to the above, communication may be directly to the Client or his appointed Agent, verbally or in writing, as and when the need arises.
- 5.2.3 Consultation with the workforce on OH&S matters will be through their Supervisors and H&S Representatives ('SHE – Reps')

5.2.4 The Principal Contractor will be responsible for the dissemination of all relevant OH&S information to the other Contractors e.g. design changes agreed with the Client and/or its Agent on its behalf and the Designer, instructions by the Client and/or his/her agent, exchange of information between Contractors, the reporting of hazardous/dangerous conditions/situations etc.

6. RESPONSIBILITIES

6.1 Client

6.1.1 The Client or his appointed Agent on his behalf will appoint each Principal Contractor for this project in writing for assuming the role of Principal Contractor as intended by the Construction Regulations and determined by the Bills of Quantities.

6.1.2 The Client or his appointed Agent on his behalf shall discuss and negotiate with the Principal Contractor the contents of the health and safety plan of the both Principal Contractor and Contractor for approval.

6.1.3 The Client or his appointed Agent on his behalf, will take reasonable steps to ensure that the health and safety plan of both the Principal Contractor and Contractor is implemented and maintained. The steps taken will include periodic audits at intervals of at least once every month.

6.1.4 The Client or his appointed Agent on his behalf, will prevent the Principal Contractor and/or the Contractor from commencing or continuing with construction work should the Principal Contractor and/or the Contractor at any stage in the execution of the works be found to:

- have failed to have complied with any of the administrative measures required by the Construction Regulations in preparation for the construction project or any physical preparations necessary in terms of the Act;
- have failed to implement or maintain their health and safety plan;
- have executed construction work which is not in accordance with their health and safety plan; or
- act in any way which may pose a threat to the health and safety of any person(s) present on the site of the works or in its vicinity, irrespective of him/them being employed or legitimately on the site of the works or in its vicinity.

6.2 Principal Contractor

6.2.1 The Principal Contractor shall accept the appointment under the terms and Conditions of Contract. The Principal Contractor shall sign and agree to those terms and conditions and shall, before commencing work, notify the Department of Labour of the intended construction work in terms of Regulation 3 of the Construction. The Principal Contractor shall submit the notification in writing prior to commencement of work and inform the Client or his Agent accordingly.

6.2.2 The Principal Contractor shall ensure that he is fully conversant with the requirements of this Specification and all relevant health and safety legislation. *This Specification is not intended to supersede the Act nor the Construction Regulations or any part of either.* Those sections of the Act and the Construction Regulations which apply to the scope of work to be performed by the Principal Contractor in terms of this contract will continue to be legally required of the Principal Contractor to comply with. The Principal Contractor will in no manner or means be absolved from the responsibility to comply with all applicable sections of the Act, the Construction Regulations or any Regulations proclaimed under the Act or which may perceivable be applicable to this contract.

- 6.2.3 The Principal Contractor shall provide and demonstrate to the Client a suitable and sufficiently documented health and safety plan based on this Specification, the Act and the Construction Regulations, which shall be applied from the date of commencement of and for the duration of execution of the works. This plan shall, as appendices, include the health and safety plans of all Sub-contractors for which he has to take responsibility in terms of this contract.
- 6.2.4 The Principal Contractor shall provide proof of his registration and good standing with the Compensation Fund or with a licensed compensation insurer prior to commencement with the works.
- 6.2.5 The Potential Principal Contractor shall, in submitting his tender, demonstrate that he has made provision for the cost of compliance with the specified health and safety requirements, the Act and Construction Regulations.
- 6.2.6 The Principal Contractor shall consistently demonstrate his competence and the adequacy of his resources to perform the duties imposed on the Principal Contractor in terms of this Specification, the Act and the Construction Regulations.
- 6.2.7 The Principal Contractor shall ensure that a copy of his health and safety plan is available on site and is presented upon request to the Client, an Inspector, Employee or Sub-contractor.
- 6.2.8 The Principal Contractor shall ensure that a health and safety file, which shall include all documentation required in terms of the provisions of this Specification, the Act and the Construction Regulations, is opened and kept on site and made available to the Client or Inspector upon request. Upon completion of the works, the Principal Contractor shall hand over a consolidated health and safety file to the Client.
- 6.2.9 The Principal Contractor shall, throughout execution of the contract, ensure that all conditions imposed on his Sub-contractors in terms of the Act and the Construction Regulations are complied with as if they were the Principal Contractor.
- 6.2.10 The Principal Contractor shall from time to time evaluate the relevance of the Health and Safety Plan and revise the same as required, following which revised plan shall be submitted to the Client and/or his/her Agent for approval.

7. SCOPE OF WORK

These specifications are applicable to the specific scope of work pertaining to the project as detailed in the tender documents. ***Refer to Project specification.***

8. HEALTH AND SAFETY FILE

The Principal Contractor must, in terms of Construction Regulation 5(7), keep a Health & Safety File on site at all times that must include all documentation required in terms of the Act and Regulations and must also include a list of all Contractors on site that are accountable to the Principal Contractor and the agreements between the parties and details of work being done.

The Health and Safety File will remain the property of the Client and/or its Agent on its behalf throughout the period of the project and shall be consolidated and handed over to the Client and/or its Agent on its behalf at the time of completion of the project.

The safety file shall contain the following documentations:

- Safety reports,
- Notification documents,

- Appointment letters,
- Records of incidents,
- Records of training,
- Records of safety meetings,
- Records of PPE provision,
- And any other document related to safety issues on site.

9. MONITORING AND REVIEWING OH&S PERFORMANCE

The Principal Contractor is required to maintain acceptable incident rate and report on this to the Client and/or its Agent on its behalf on a monthly basis. The frequency rates must reflect permanent disability, lost workdays, restricted workdays, medical treatment and first aid treatment.

10. HAZARD IDENTIFICATION AND RISK ASSESSMENT

The Principal Contractor is required to develop Risk Assessments, Standard Working Procedures (SWP) and Method Statements for each activity executed in the contract or project. The identification of hazards is over and above the hazards identification program and those hazards identified during the drafting of the Health and Safety Plan. Hazard identification should be conducted continuously over and above the baseline risk assessment.

11. ARRANGEMENTS FOR MONITORING AND REVIEW

11.1 Monthly Audit by Client

The Client and/or its Agent on its behalf will be conducting Periodic Audits at times agreed with the Principal Contractor Audit to comply with Construction Regulation 4(1)(d) to ensure that the principal Contractor has implemented, is adhering to and is maintaining the agreed and approved OH&S Plan.

11.2 Other audits and inspections

The Client and/or its Agent on its behalf reserves the right to conduct any other ad hoc audits and inspections as it and/or its Agent on its behalf deem necessary.

A representative of the Principal Contractor and the relevant Health and Safety Representative(s) (SHE-Reps) must accompany the Client and/or its Agent on its behalf on all Audits and Inspections and may conduct their own audit/inspection at the same time. Each party will, however, take responsibility for the results of his/her own audit/inspection results. The Client and/or its Agent on its behalf may require to be handed a copy of the minutes of the previous Health and Safety Committee meeting reflecting possible recommendations made by that committee to the Employer for reference purposes and any other health and safety related issues.

11.3 Reports

11.3.1 The Principal Contractor shall report all incidents where an employee is injured on duty to the extent that he/she dies, becomes unconscious, loses a limb or part of a limb, is injured or becomes ill to such a degree that he/she is likely either to die or to suffer a permanent physical defect or likely to be unable for a period of at least 14 days either to work or continue with the activity for which he/she was usually employed, or where a major incident occurred, the health or safety of any person was endangered, where a dangerous substance was spilled, the uncontrolled release of any substance under pressure took place, machinery or any part of machinery fractured or failed resulting in flying, falling or uncontrolled moving objects, machinery ran out of control, to the Provincial Director of the Department of Labour within seven days and at the same time to the Client and/or its Agent on its behalf.

11.3.2 The Principal Contractor is required to provide the Client and/or its Agent on its behalf with copies of all statutory reports required in terms of the Act and the Regulations.

11.3.3 The Principal Contractor is required to provide the Client and/or its Agent on its behalf with a monthly "SHE Risk Management Report".

11.3.4 The Principal Contractor is required to provide the Client and/or its Agent on its behalf with copies of all internal and external accident/incident investigation reports. As soon as the occurrence of any accident/incident of whatever nature comes to the notice of the Principal Contractor, it shall be reported immediately to any of the following:

11.4 Review

The Principal Contractor is to review the Hazard Identification, Risk Assessments and Standard Work Processes at each Production Planning and Progress Report meeting as the construction work develops and progresses and each time changes are made to the designs, plans and construction methods and processes. The Principal Contractor must provide the Client and/or its Agent on its behalf, and all other concerned parties with copies of any changes, alterations or amendments

11.5 Site Safety Rules

11.5.1 Site OH&S Rules

The Principal Contractor must develop a set of site-specific OH&S rules that will be applied to regulate the Health and Safety Plan and associated aspects of the construction. When required for a site by law, visitors and non-employees upon entering the site shall be issued with the proper Personal Protective Equipment (PPE) as and when necessary.

11.5.2 Security Arrangements

The Principal Contractor must establish site access rules and implement and maintain these throughout the construction period. Access control must include the rule that non-employees shall at all times be provided with fulltime supervision while on site. The Principal Contractor must develop a set of Security rules and procedures and maintain these throughout the construction period.

If not already tasked to the H&S Officer appointed in terms of Construction Regulation 6(6), the Principal Contractor must appoint a competent Emergency Controller who must develop contingency plans for any emergency that may arise on site as indicated by the risk assessments. These must include a monthly practice/testing program for the plans

11.6 Training

The Principal Contractor shall ensure that all employees under the his or her control are informed, instructed and trained by a competent person regarding any hazard and the related work procedures before any work commences, and thereafter at such times as may be determined in the risk assessment.

The Principal Contractor shall ensure that all labourers are informed regarding any hazard as stipulated in the risk assessment before any work commences, and thereafter at such times as may be determined in the risk assessment.

The Principal Contractor shall ensure that as far as is reasonably practicable, ergonomic related hazards are analysed, evaluated and addressed in the risk assessment.

No Principal Contractor shall allow or permit any employee to enter any site, unless such person has undergone health and safety induction training pertaining to the hazards prevalent on the site at the time of entry.

The Principal Contractor shall ensure that all visitors to a construction site undergoes health and safety instruction pertaining to the hazards prevalent on the site and shall be provided with the necessary personal protective equipment: Provided that where visits are made only to the site office which is not in direct contact with the construction work activities, those health and safety instructions and the provision of personal protective equipment may not apply.

The contents and syllabi of all training required by the Act and Regulations including any other related or relevant training as required must be included in the Principal Contractor's Health and Safety Plan and Health and Safety File.

11.6.1 General Induction Training

The Principal contractor must ensure that the employees on site are conversant with the general health and safety requirements on site. All employees of the Principal and other Contractors must be in possession of proof of General Induction training.

11.6.2 Site Specific Induction Training

All employees of the Principal and other Contractors must be in possession of Site Specific Occupational Health and Safety Induction or other qualifying training.

11.6.3 Other Training

All operators, drivers and users of construction vehicles, mobile plant and other equipment must be in possession of valid proof of training. All employees in jobs requiring training in terms of the Act and Regulations must be in possession of valid proof of training as follows:

- General Induction (Section 8 of the Act)
- Site/Job Specific Induction (also visitors) (Sections 8 & 9 of the Act)
- Site/Project Manager
- Construction Supervisor
- OH&S Representatives (Section 18 (3) of the Act)
- Training of the Appointees indicated in 12.6.1 & 12.6.2 above
- Operation of Cranes (Driven Machinery Regulations 18 (11))
- Operators & Drivers of Construction Vehicles & Mobile Plant (Construction Regulation 21)
- Basic Fire Prevention & Protection (Environmental Regulations 9 and Construction Regulation 27)
- As a minimum basic First Aid to be upgraded when necessary (General Safety Regulations 3)
- Storekeeping Methods & Safe Stacking (Construction Regulation 26)
- Emergency, Security and Fire Coordinator

11.7 Accident and Incident Investigation

The Principal Contractor is responsible to oversee the investigation of all accidents/incidents where employees and non-employees were injured to the extent that he/she/they had to receive first aid or be referred for medical treatment by a doctor, hospital or clinic, (General Administrative Regulation 9). The Principal Contractor is responsible for the investigation of all non-injury incidents as described in Section 24 (1) (b) & (c) of the Act and keeping a record of the results of such investigations including the steps taken to prevent similar incidents in future.

The Principal Contractor is responsible for the investigation of all road traffic accidents relating to the construction site and keeping a record of the results of such investigations including the steps taken to prevent similar accidents in future. Notwithstanding the requirements of Section 24 of the Act, ALL incidents shall be investigated and reported on in writing, irrespective of whether such incident gave rise to injury or damage.

11.8 H&S Representatives and H&S Committees

11.8.1 Designation of H&S Representatives

Where the Principal Contractor employs more than 20 persons (including the employees of other Contractors (sub-contractors) he has to appoint one H&S Representatives for every 20 employees or part thereof. (Section 17 of the Act and General Administrative Regulation 6. & 7.) H&S Representatives have to

be designated in writing and the designation shall be in accordance with the Collective Agreement as concluded between the parties as is required in terms of General Administration Regulation 6.

11.8.2 Duties and Functions of the H&S Representatives

The Principal Contractor must ensure that the designated H&S Representatives conduct at least a weekly inspection of their respective areas of responsibility using a checklist and report thereon to the Principal Contractor, after which these reports shall be consolidated for submission to the Health and Safety Committee. H&S Representatives must be included in and be part of accident/incident investigations. H&S Representatives shall be members of at least one H&S Committee and must attend all meetings of that H&S committee.

11.8.3 Establishment of H&S Committee(s)

The Principal Contractor must establish H&S Committees consisting of designated H&S Representatives together with a number of Employers Representatives appointed as per Section 19(3) that are not allowed to exceed the number of H&S Representatives on the committee. The persons nominated by the employer on an H&S Committee must be designated in writing for such period as may be determined by the project period. The H&S Committee shall co-opt advisory (temporary) members and determine the procedures of the meetings including the chairmanship.

12. HOUSE KEEPING

Good housekeeping will be maintained at all times as per Construction Regulation No. 25. Poor housekeeping contributes to three major problems, namely, costly or increased accidents, fire or fire hazards and reduction in production. Good housekeeping will enhance production time.

Particular emphasis is to be placed on the following crucial elements of a construction site:

- Phase priorities and production/plant layout
- Enclosures
- Pits, openings and shoring
- Storage facilities
- Effective, sufficient and maintained lighting or illumination
- Principal sources of injuries e.g. stairways, runways, ramps, loose building material
- Oil, grease, water, waste, rubble, glass, storm water
- Colour coding
- Demarcations
- Pollution
- Waste disposal
- Ablution and hygiene facilities
- First aid disposals
- Hazardous chemical substances

This list must not be taken to be exclusive or exhaustive.

In promotion of environmental control all waste, rubble, scrap etc, will be disposed of at a registered dumping site and records will be maintained. Where it is found to be impractical to use a registered dump site or it is not available, the Principal Contractor will ensure that the matter is brought to record with the client or his representative, after which suitable, acceptable alternatives will be sought and applied. Dross and refuse from metals, and waste matters or by-products whose nature is such that they are poisonous or capable of fermentation, putrefaction or constituting a nuisance shall be treated or disposed of by methods approved of by an inspector.

13. OPERATIONAL CONTROL

The Principal Contractor shall take reasonable steps to ensure that necessary control measures are taken to promote safe working environment during all operational works. Routine safety inspections shall be carried out to ensure plant; machinery and tools are safe enough for employees to work with. Operational control measures shall be taken for the following activities and plant or machinery where applicable:

- Fall protection;
- Excavation work;
- Scaffolding;

- Mobile plants;
- Electrical installation and machinery; and
- Other associated activities.

14.SUB CONTRACTORS

The Principal Contractor shall ensure that agreements are entered into by all sub-contractors on site, and ensure that all sub-contractors are in compliance with the health and safety standards on site. Particulars of sub-contractors involved in specialised work such as blasting, concrete works and electrical installations must be submitted to the designers for approval and their safety plans submitted to the Client for approval.

15.OFFENCES AND PENALTIES

Any contractor, who does not comply with the requirements of the Act, will be penalised or punished as per Section 38 of the Act. The principal contractor must also note that the Client may stop the execution of construction work if it is not in accordance with the health and safety plan or if it poses a threat on the health and safety of employees and the public.



CAPRICORN DISTRICT MUNICIPALITY

C7. Site Information

7.1 General

This section describes the site at the time of the tender in order to enable the tenderer to price his tender accordingly and to decide upon his method of working, programming and risks.

The tenderer shall inform him / her on the nature of the site and inspect the site.

The Employer will consider a tender only if the site inspection and/or tenderer's meeting arranged by the Engineer has been attended by a representative who must:

- Be suitably qualified to comprehend the implications of the work involved, and
- Be the tenderer him/herself or a person in the direct employ of the tenderer

7.2 Site location

Nairin Village Water Supply project, which falls within the Blouberg Water Cluster, is located in the Capricorn District in the Northern region of the Limpopo Province and falls within the jurisdiction of Blouberg Local Municipality. The project includes three beneficiary sections, namely Ga-Molefe, Sifihlampsana and Ga-Tshabalala with central locality coordinates are as follows:

Ga-Molefe Village:

- Longitude: (E) 29° 02' 07.96"
- Latitude: (S) 23° 08' 31.69"

Sifihlampsana Village:

- Longitude: (E) 29° 02' 02.18"
- Latitude: (S) 23° 09' 05.04"

Ga-Tshabalala Village:

- Longitude: (E) 29° 00' 54.67"
- Latitude: (S) 23° 09' 07.24"

Locality Details

- Province : Limpopo Province
- District : Capricorn District Municipality
- Municipality : Blouberg Local Municipality

Nairin village normally receive about 520mm of rain per year, with most rainfall occurring during summer. The monthly distribution of the average daily maximum temperatures indicates that the average midday temperatures of both areas range from 20oC in June and July to 27oC from January to March.

7.3 Access to site and restrictions

The construction sites are situated in the existing villages as mentioned in 6.2. These sites can be reached via existing streets/roads and Provincial Roads

The operation of construction vehicles on existing roads or streets, or on streets which have been completed on the level of sub-base or base or bituminous surface treatment, shall be limited to traffic with an axle load not exceeding that allowed by the Road Traffic Ordinance of the authority concerned, or any amendment thereof. Hauling is strictly forbidden on sections of streets that have been completed as described above. The Contractor shall make use of temporary haul roads, or

where not practically possible, program his work in such a manner that the haulage of materials shall be restricted to that required for the particular section of street. No additional payment shall be made for the use of temporary haul roads and all relevant costs shall be deemed to be covered by the appropriate rates.

The Contractor must note that no additional payment will be made for the construction of temporary access roads to the construction site, borrow-areas or to the spoil sites, except for payment made under payment item A.8.3.2.2 of SANS 1200 A.

If the Contractor does not make use of existing streets for the hauling of materials to or from the site, he shall be held responsible to clear any spillage caused by his activities on or near the roads by whatever means necessary, within two (2) days after such spillage has occurred. No additional payment will be made for the clearance of spillage and all relevant costs will be deemed to be covered under the relevant items.

7.4 Existing services, servitudes and way leaves

All the known existing services are indicated on the drawings.

7.5 Security

The security of the Contractor's plant, employers, materials and site camp will be the Contractor's responsibility.

7.6 Nature of ground and subsoil conditions

The Contractor shall familiarize himself with the conditions on site.

The materials on site mainly consist of soft and hard material. The majority of excavation will be in weathered and hard granite.

Also refer to the Project Specification "*PS 4 :NATURE OF GROUND AND SUBSOIL CONDITIONS ON SITE*".



CAPRICORN DISTRICT MUNICIPALITY

C.8 Drawings

The following drawings, for tender purposes only, form part of this contract.

<u>DESCRIPTION:</u>	<u>DRAWING NO:</u>
EPWP branded project Name Board.	NAIR-STD-01
LOCALITY MAP	NAIR-LM-01
KEY LAYOUT PLAN	NAIR-KP-01
RETICULATION LAYOUT PLAN SHEET 1 OF 4	NAIR-LP-01
RETICULATION LAYOUT PLAN SHEET 2 OF 4	NAIR-LP-02
RETICULATION LAYOUT PLAN SHEET 3 OF 4	NAIR-LP-03
RETICULATION LAYOUT PLAN SHEET 4 OF 4	NAIR-LP-04
EPWP BRANDED PROJECT NAME BOARD	NAIR-STD-01
AIR VALVE CHAMBER	NAIR-STD-02
SCOUR VALVE CHAMBER	NAIR-STD-03
ISOLATION VALVE CHAMBER	NAIR-STD-04
THRUST BLOCK DETAIL	NAIR-STD-05
PIPELINE MAKER	NAIR-STD-06
BEDDING DETAILS	NAIR-STD-07
STANDPIPE & YARD CONNECTION DETAILS	NAIR-STD-08

CONCRETE PALISADE FENCE	NAIR-STD-09
STEEL SLIDING GATE (4.5m)	NAIR-STD-10
TYPIC FLOW CONTROL VALVE CHAMBER	NAIR-STD-11
BOREHOLE PUMP STATION MANFOLD TYPICAL LAYOUT	NAIR-STD-12

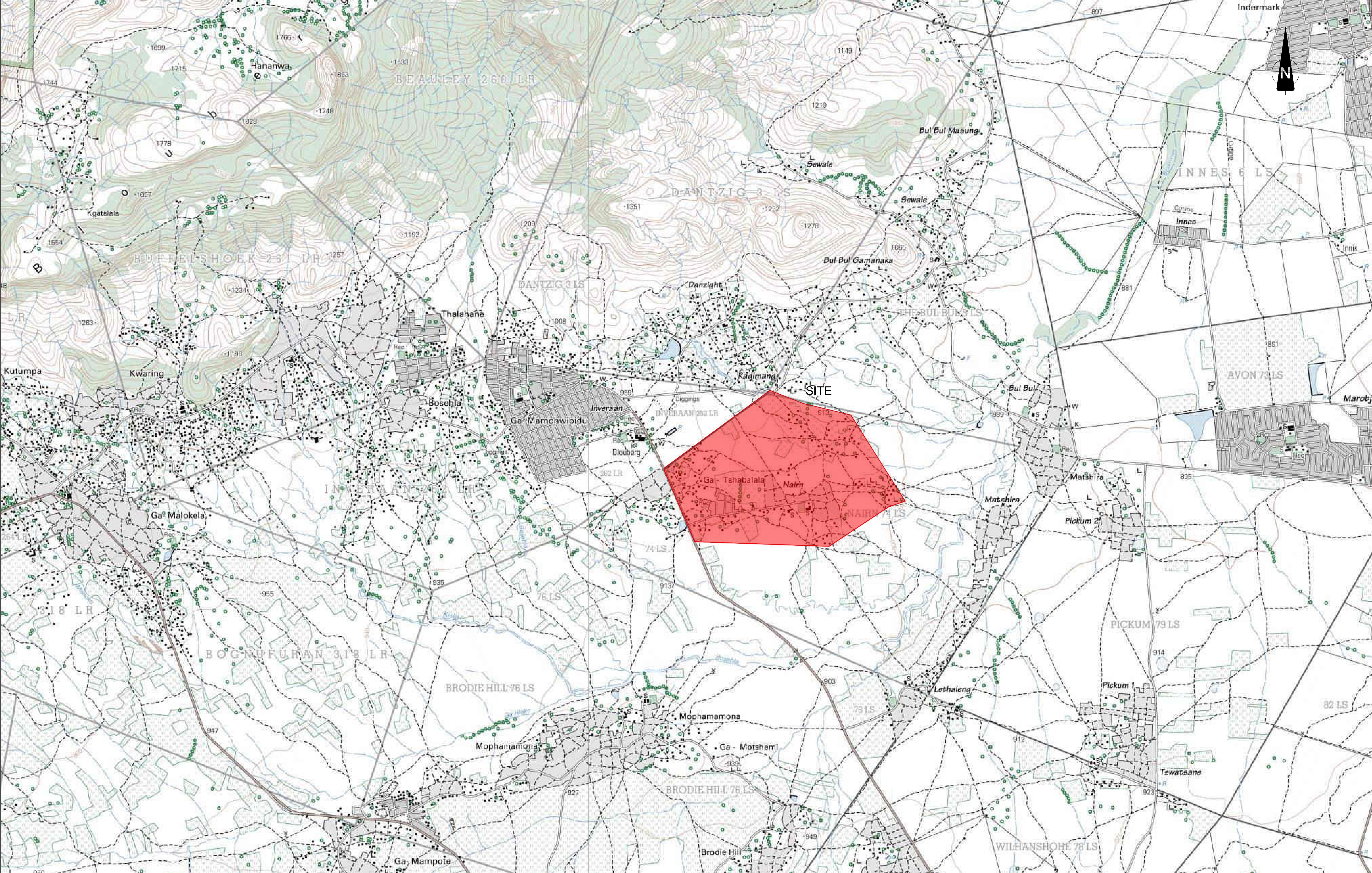

ISSUED FOR TENDER		DESIGNED BY	ATT	<p>CAPRICORN DISTRICT MUNICIPALITY</p>  <p>CAPRICORN DISTRICT MUNICIPALITY P.O. BOX 4100 POLOKWANE 0699</p>	SADC PROJECT CONSULTING & ORBITALS		CLIENT		ISSUED DATE	SHEET 1 OF 1	
PURPOSES		CHECKED BY	ATT		<p>TRADING PROJECT JV</p>  <p>UNIT 1 TYBACT PLACE YORK HOUSE WAERFALL PARK BEKKER ROAD MIDRAND 1685</p>		CAPRICORN DISTRICT MUNICIPALITY		JUNE 2022		SCALE
SCALE ON REDUCED DRAWING		DRAWN BY	NS				<p>PROJECT</p> <p>WATER</p>		DRAWING SIZE		1:25 000
No	DATE	CHECKED BY	ATT		<p>MUNICIPAL MANAGER</p> <p>CONSULTING ENGINEER</p>		<p>PROJECT</p> <p>DISCIPLINE</p> <p>DRAWING TITLE</p>		A1		DRAWING NUMBER
						<p>WATER</p> <p>LOCALITY MAP</p>		CONSULTANTS PROJECT NUMBER	REV		
								ORB-NAIR-W74/2020/2021	0		

LEGEND:

- PROPOSED 75mmØ uPVC CLASS 9 PIPE
- PROPOSED 200mmØ uPVC CLASS 12 BULK PIPE
- PROPOSED 160mmØ uPVC CLASS 12 BULK PIPE
- PROPOSED 160mmØ uPVC CLASS 9 BULK PIPE

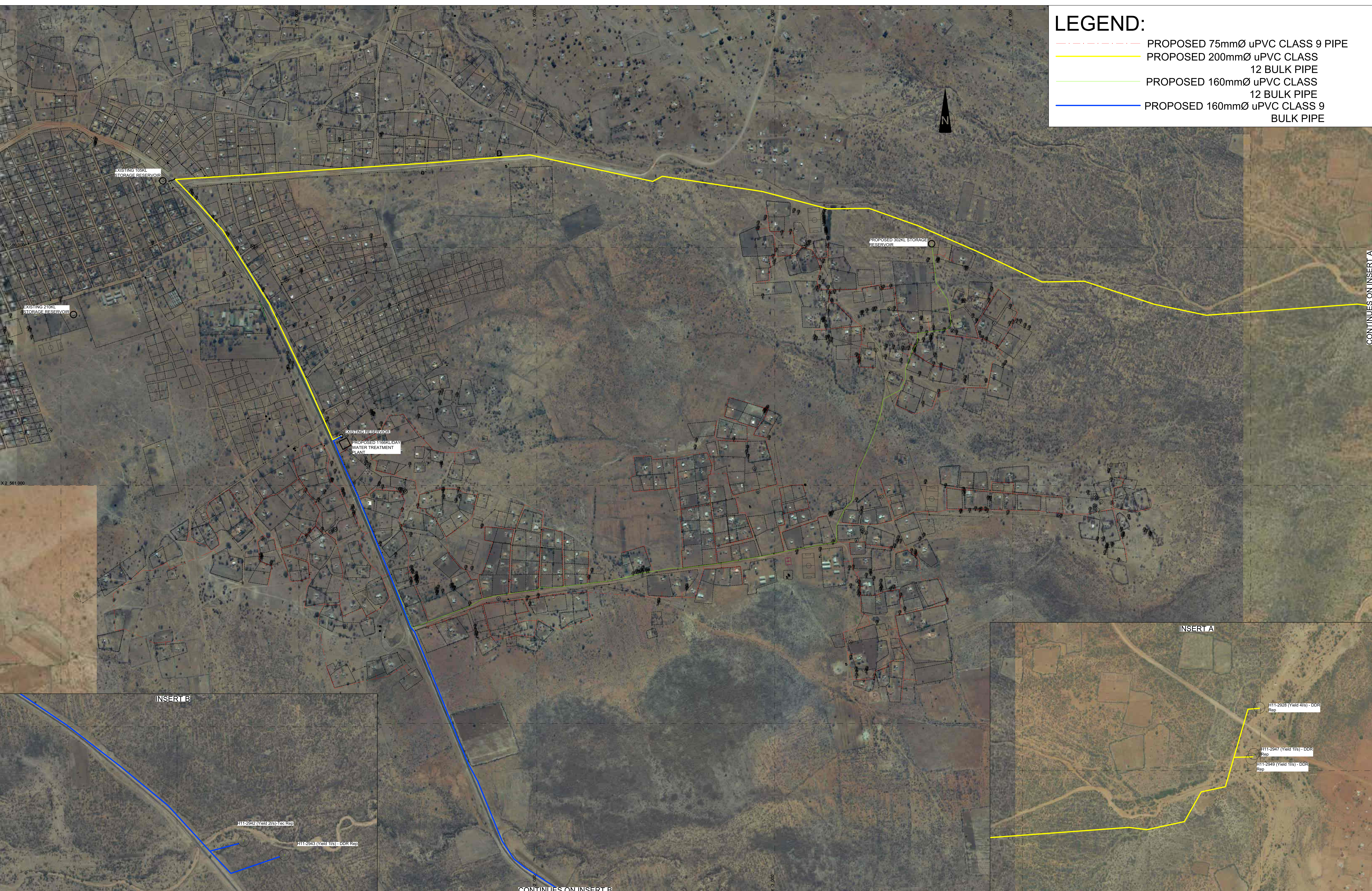





CONTINUES ON INSERT A

INSERT B

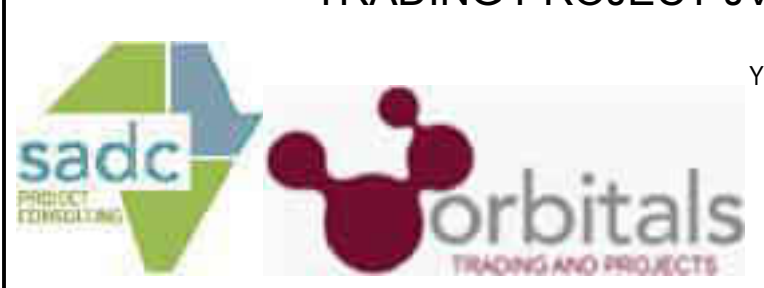
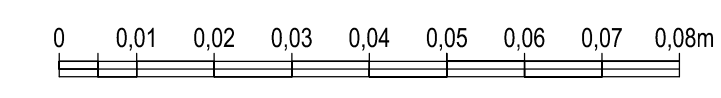
INSERT A

CONTINUES ON INSERT B

	ISSUED FOR TENDER	DESIGNED BY ATT	ATT	CAPRICORN DISTRICT MUNICIPALITY CAPRICORN DISTRICT MUNICIPALITY P.O. BOX 4100 POLOKWANE 0699	 SADC PROJECT CONSULTING & ORBITALS TRADING PROJECT JV UNIT 1 TYBACT PLACE YORK HOUSE WAERFALL PARK BEKKER ROAD MIDRAND 1685	CLIENT: CAPRICORN DISTRICT MUNICIPALITY	ISSUED DATE JUNE 2022	SHEET 1 OF 1	
	 SCALE ON REDUCED DRAWING	CHECKED BY ATT	ATT	 CAPRICORN DISTRICT MUNICIPALITY	 MUNICIPAL MANAGER DATE	PROJECT: NAIRN VILLAGE WATER SUPPLY	DRAWING SIZE A0	SCALE 1:5 000	
		DRAWN BY N.S	N.S		 CONSULTING ENGINEER DATE	DISCIPLINE: WATER	CONSULTANTS PROJECT NUMBER ORB-NAIR-W74/2020/2021	DRAWING NUMBER NAIR-KP-01	REV 0
No	DATE	CONSULT	DIR			DRAWING TITLE: KEY LAYOUT PLAN			

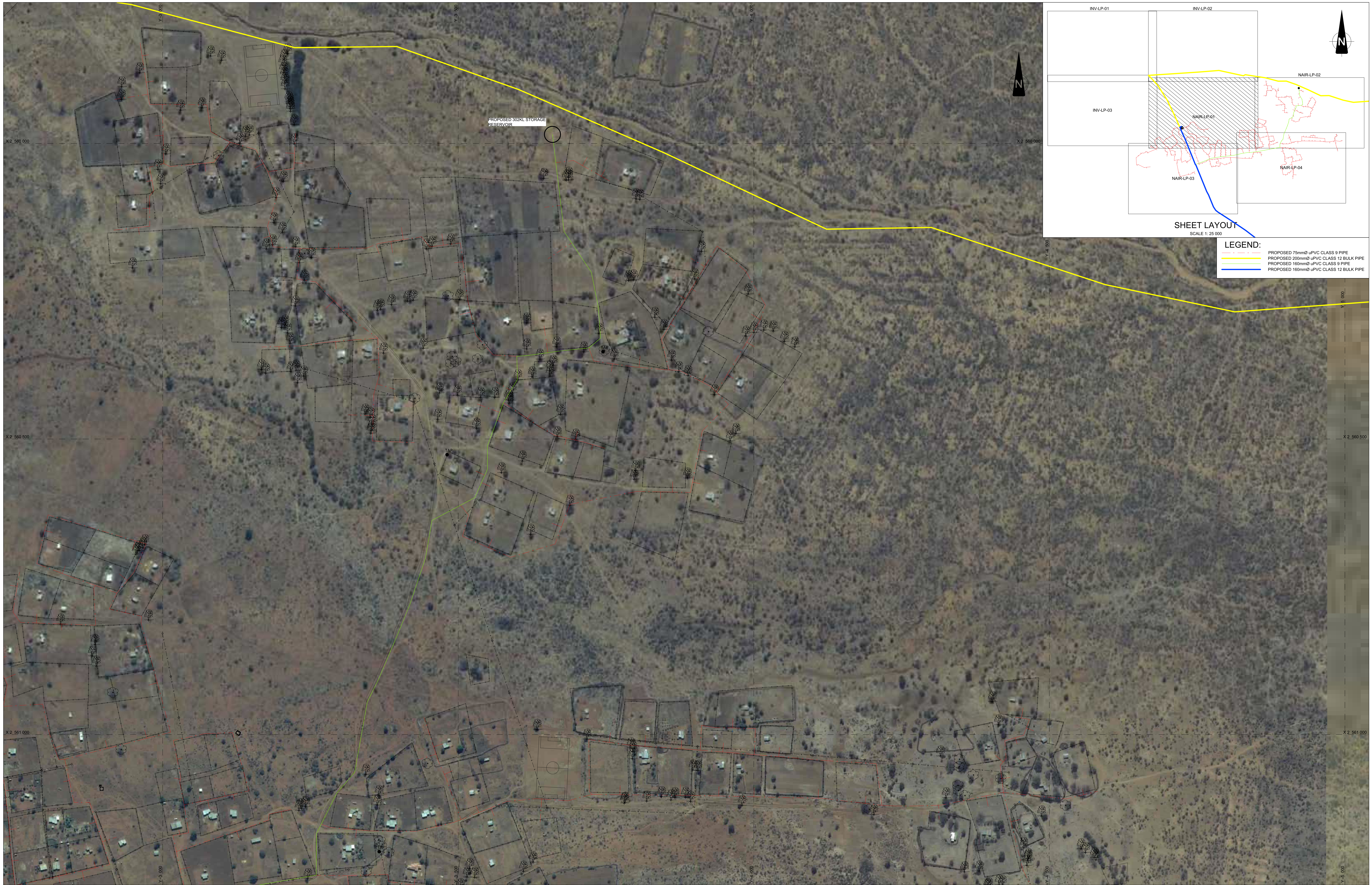

No	DATE	CONSULT	DIR

ISSUED FOR TENDER

SCALE ON REDUCED DRAWING

DESIGNED BY	ATT
CHECKED BY	ATT
DRAWN BY	N.S
CHECKED BY	ATT

CAPRICORN DISTRICT MUNICIPALITY
 CAPRICORN DISTRICT MUNICIPALITY
 P.O. BOX 4100
 POLOKWANE
 0699

SADC PROJECT CONSULTING & ORBITALS TRADING PROJECT JV

UNIT 1 TYBACT PLACE
 YORK HOUSE WAERFALL PARK
 BEKKER ROAD
 MIDRAND
 1685

MUNICIPAL MANAGER	DATE
CONSULTING ENGINEER	DATE

CLIENT:	CAPRICORN DISTRICT MUNICIPALITY
PROJECT:	NAIRIN VILLAGE WATER SUPPLY
DISCIPLINE:	WATER
DRAWING TITLE:	RETICULATION LAYOUT PLAN

ISSUED DATE	JUNE 2022	SHEET	1	OF	4
DRAWING SIZE	A0	SCALE	1:2 000		
CONSULTANTS PROJECT NUMBER	ORB-NAIR-W74/2020/2021	DRAWING NUMBER	NAIR-LP-01	REV	0

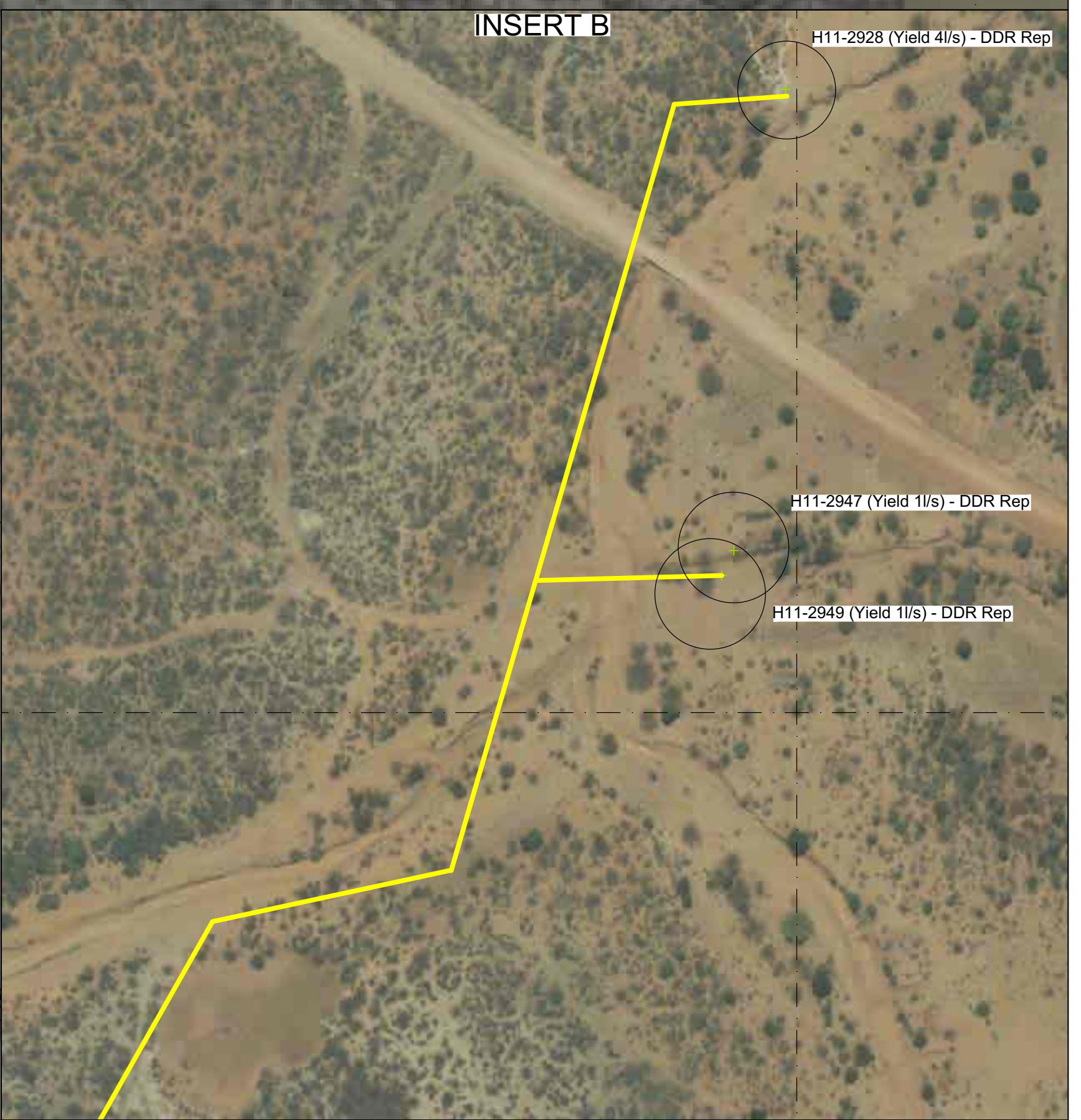

		ISSUED FOR TENDER		DESIGNED BY: ATT	CAPRICORN DISTRICT MUNICIPALITY CAPRICORN DISTRICT MUNICIPALITY P.O. BOX 4100 POLOKWANE 0699		SADC PROJECT CONSULTING & ORBITALS TRADING PROJECT JV UNIT 1 TYBACT PLACE YORK HOUSE WAERFALL PARK BEKKER ROAD MIDRAND 1685		CLIENT: CAPRICORN DISTRICT MUNICIPALITY	ISSUED DATE: JUNE 2022	SHEET 2 OF 4	
		SCALE ON REDUCED DRAWING 0 0.01 0.02 0.03 0.04 0.05 0.06 0.07 0.08m		CHECKED BY: ATT					PROJECT: NAIRIN VILLAGE WATER SUPPLY	DRAWING SIZE: A0	SCALE: 1:2 000	
				DRAWN BY: N.S					DISCIPLINE: WATER	CONSULTANTS PROJECT NUMBER: ORB-NAIR-W74/2020/2021		
No	DATE	CONSULT	DIR	CHECKED BY: ATT					DRAWING TITLE: RETICULATION LAYOUT PLAN	DRAWING NUMBER: NAIR-LP-02	REV: 0	

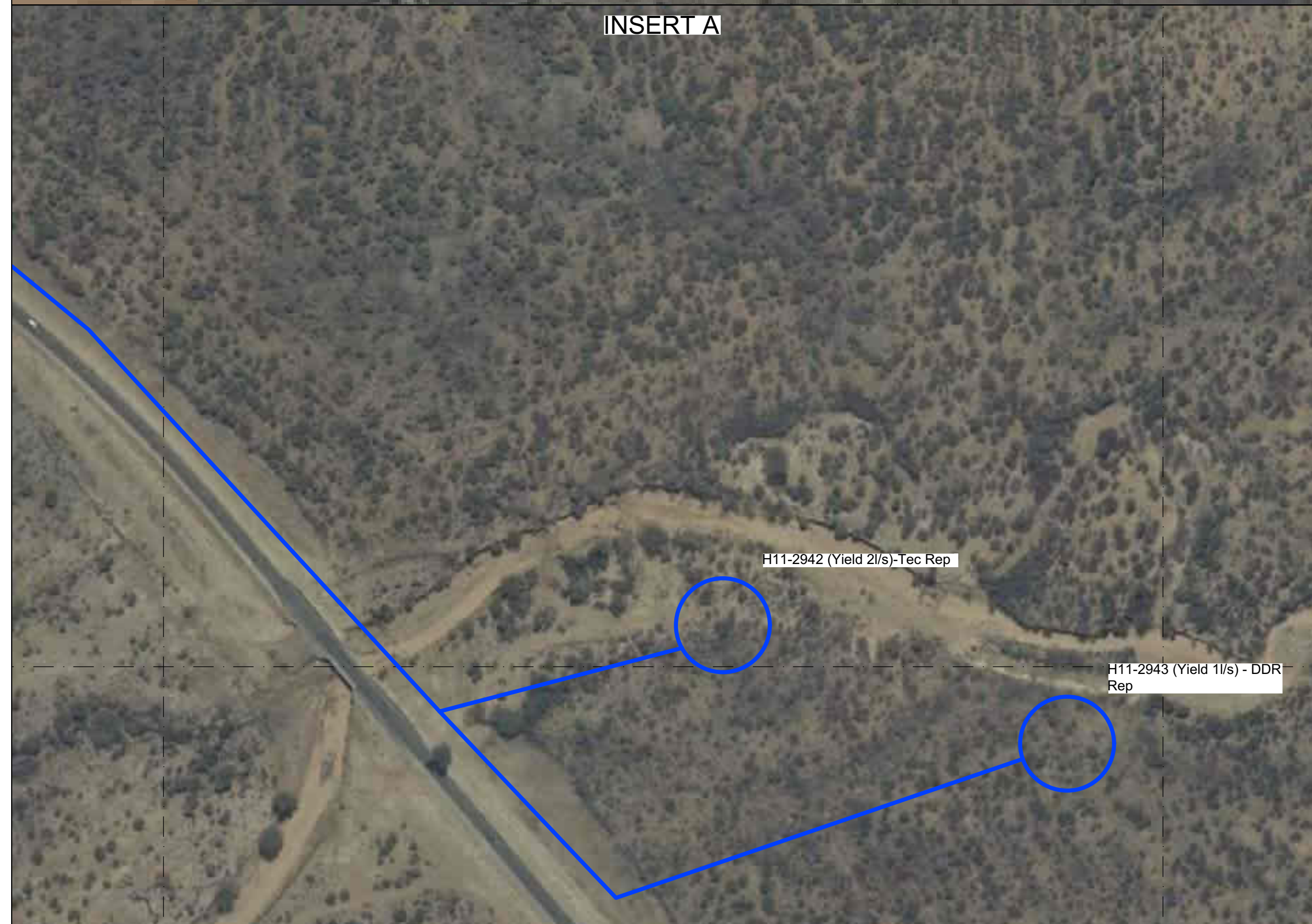

LEGEND:

- PROPOSED 75mmØ uPVC CLASS 9 PIPE
- PROPOSED 200mmØ uPVC CLASS 12 BULK PIPE
- PROPOSED 160mmØ uPVC CLASS 9 PIPE
- PROPOSED 160mmØ uPVC CLASS 12 BULK PIPE

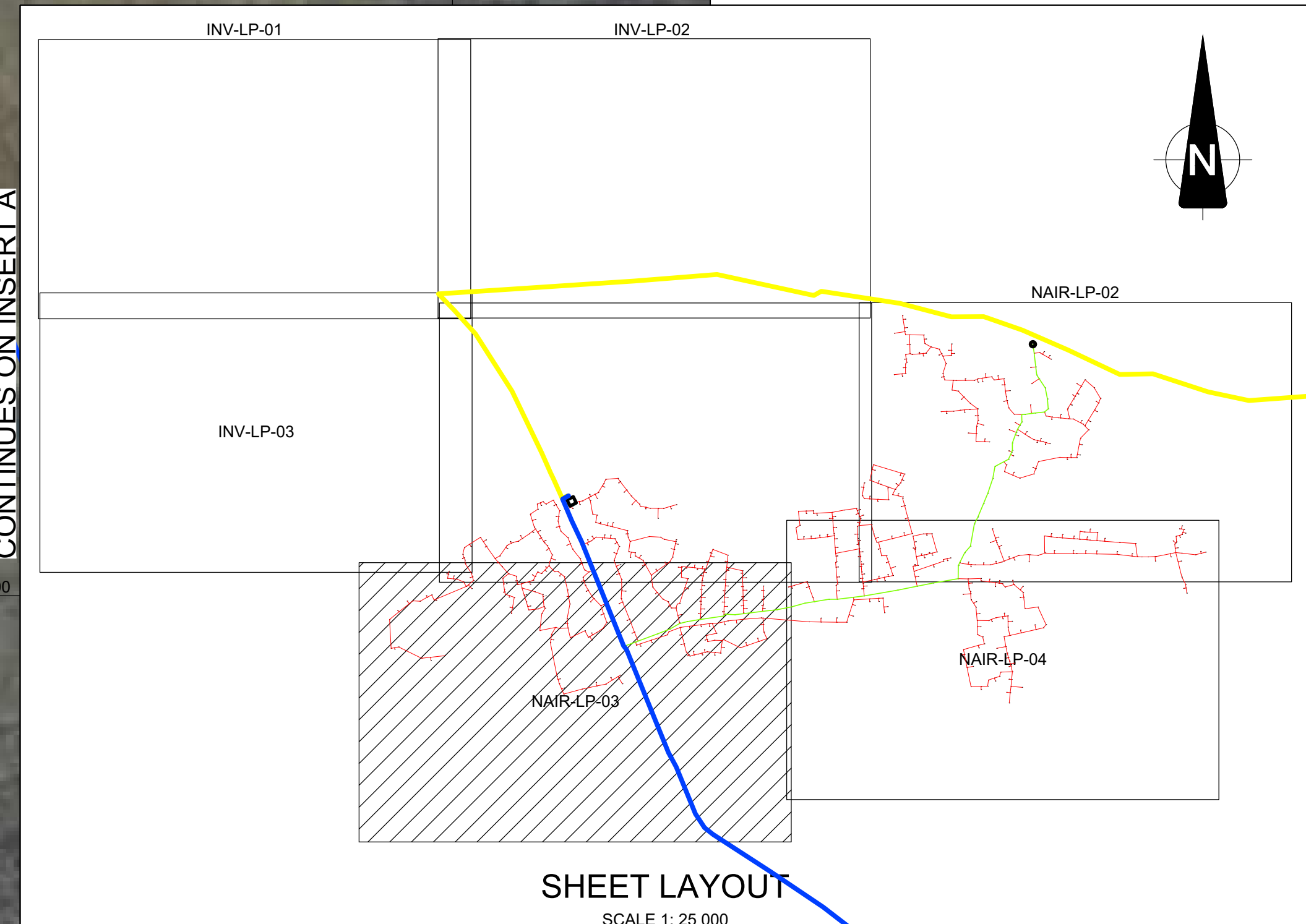

No	DATE	CONSULT	DIR

ISSUED FOR TENDER

SCALE ON REDUCED DRAWING

DESIGNED BY	ATT
CHECKED BY	ATT
DRAWN BY	N.S
CHECKED BY	ATT

CAPRICORN DISTRICT MUNICIPALITY
 CAPRICORN DISTRICT MUNICIPALITY
 P.O. BOX 4100
 POLKOWANE
 0699

SADC PROJECT CONSULTING & ORBITALS TRADING PROJECT JV

UNIT 1 TYBACT PLACE
 YORK HOUSE WAERFALL PARK
 BEKKER ROAD
 MIDRAND
 1685

MUNICIPAL MANAGER	DATE
CONSULTING ENGINEER	DATE

CLIENT:	CAPRICORN DISTRICT MUNICIPALITY
PROJECT:	NAIRIN VILLAGE WATER SUPPLY
DISCIPLINE:	WATER
DRAWING TITLE:	RETICULATION LAYOUT PLAN

ISSUED DATE	JUNE 2022	SHEET	3 OF 4
DRAWING SIZE	A0	SCALE	1:2 000
CONSULTANTS PROJECT NUMBER	ORB-NAIR-W74/2020/2021	DRAWING NUMBER	NAIR-LP-03
		REV	0



LEGEND:

	PROPOSED 75mmØ uPVC CLASS 9 PIPE
	PROPOSED 200mmØ uPVC CLASS 12 BULK PIPE
	PROPOSED 160mmØ uPVC CLASS 9 PIPE
	PROPOSED 160mmØ uPVC CLASS 12 BULK PIPE

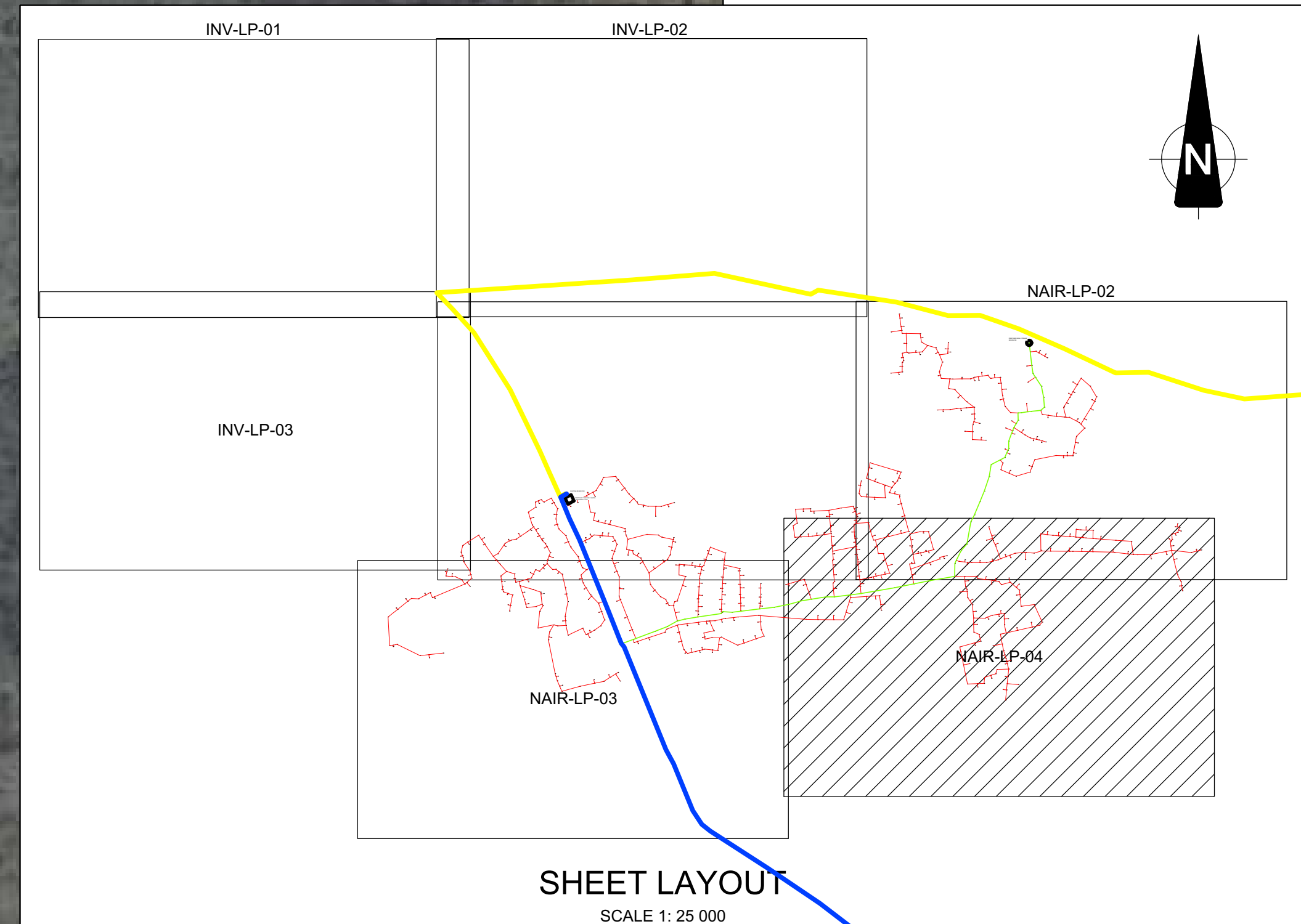

No	DATE	CONSULT	DIR

ISSUED FOR TENDER

SCALE ON REDUCED DRAWING

DESIGNED BY	ATT
CHECKED BY	ATT
DRAWN BY	N.S
CHECKED BY	ATT

CAPRICORN DISTRICT MUNICIPALITY
CAPRICORN DISTRICT MUNICIPALITY
P.O. BOX 4100
POLKOWANE
0699

SADC PROJECT CONSULTING & ORBITALS TRADING PROJECT JV

UNIT 1 TYBACT PLACE
YORK HOUSE WAERFALL PARK
BEKKER ROAD
MIDRAND
1685

MUNICIPAL MANAGER	DATE
CONSULTING ENGINEER	DATE

CLIENT:	CAPRICORN DISTRICT MUNICIPALITY
PROJECT:	NAIRIN VILLAGE WATER SUPPLY
DISCIPLINE:	WATER
DRAWING TITLE:	RETICULATION LAYOUT PLAN

ISSUED DATE	JUNE 2022	SHEET	4 OF 4
DRAWING SIZE	A0	SCALE	1:2 000
CONSULTANTS PROJECT NUMBER	ORB-NAIR-W74/2020/2021	DRAWING NUMBER	NAIR-LP-04
		REV	0

PROJECT DETAILS:
NAME OF PROJECT: NAIRIN VILLAGE WATER SUPPLY
PROJECT NUMBER: ORB-NAIR-W74/2020/2021
DURATION: 15 MONTHS
CONTRACT NUMBER: INF-W02/2022/2023

ENGINEER/CONSULTANT:

SADC PROJECT CONSULTING & ORBITALS
TRADING AND PROJECTS JV
STAND NO 19A
CHURCH STREET
POLOKWANE 0700
CELL: 071 413 7467

CONTRACTOR:

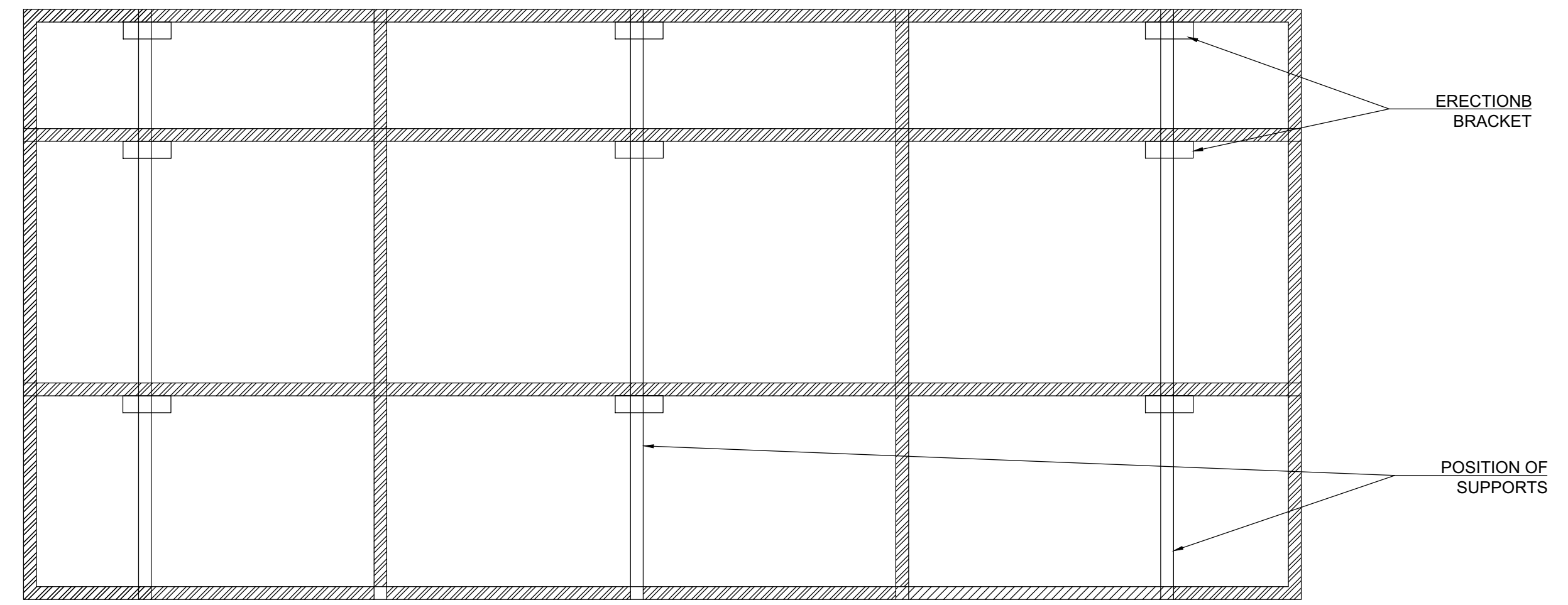

REAR SIDE BRACING

CONTRACT NAME-BOARD

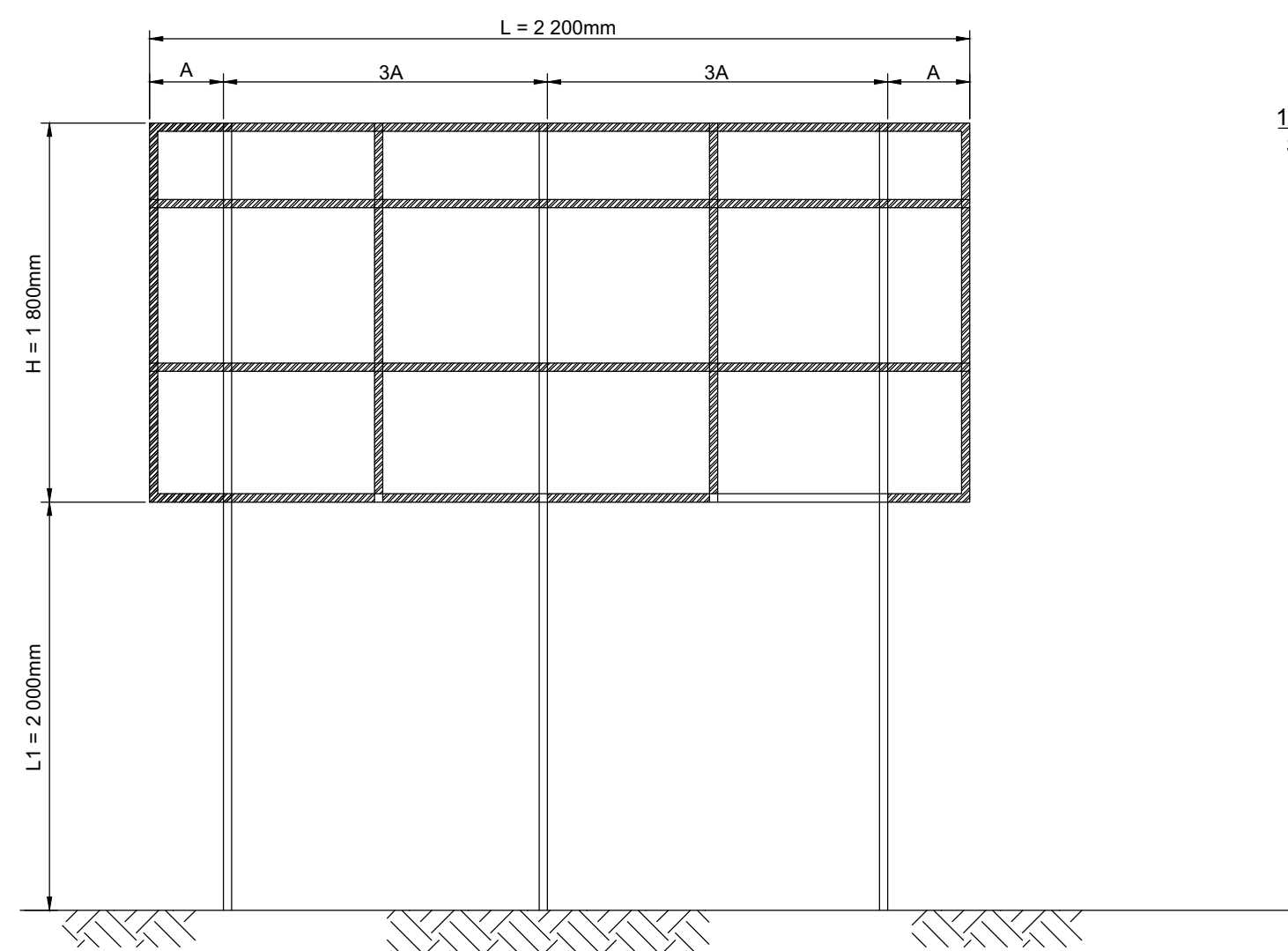

BACK ELEVATION

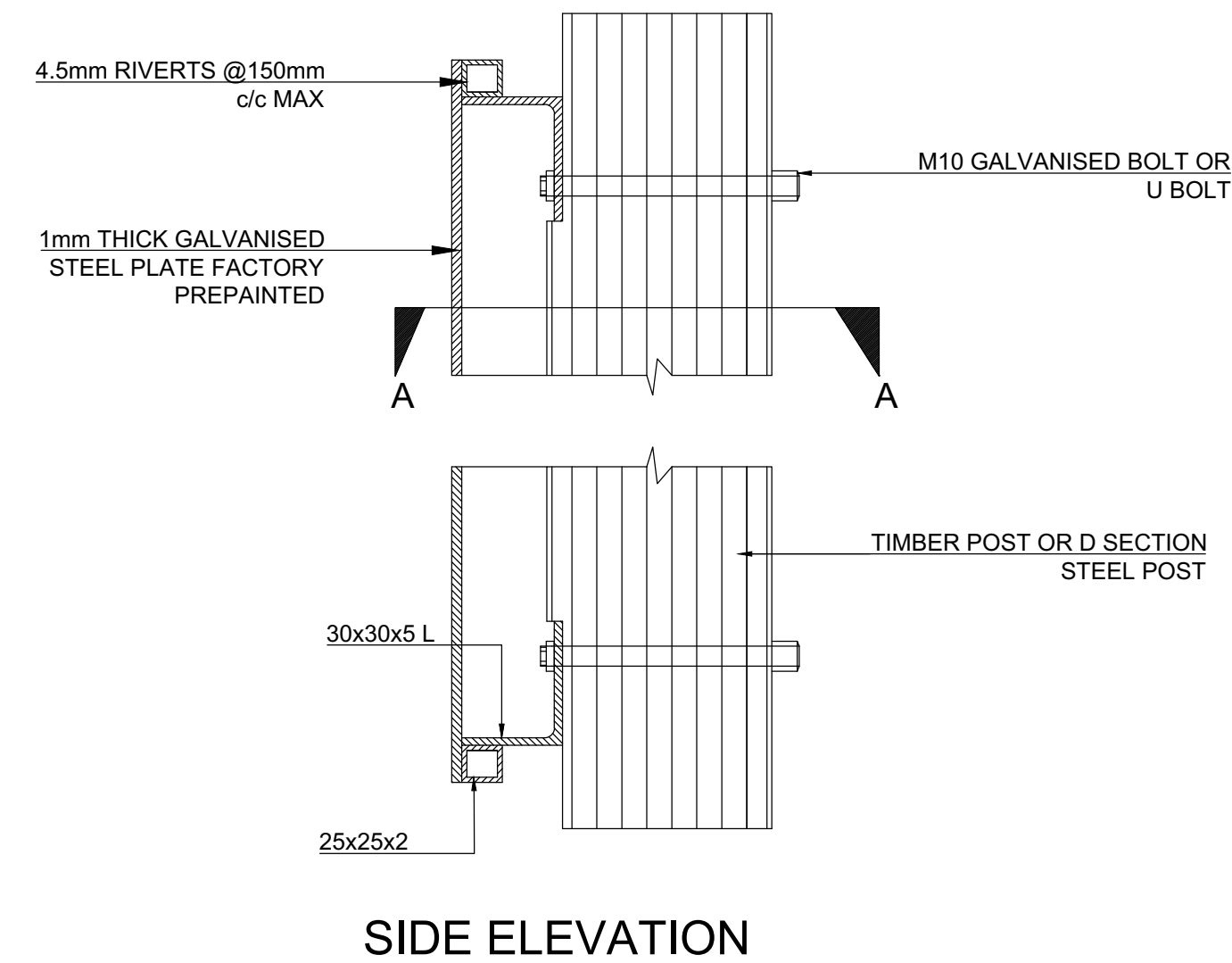

SIDE ELEVATION

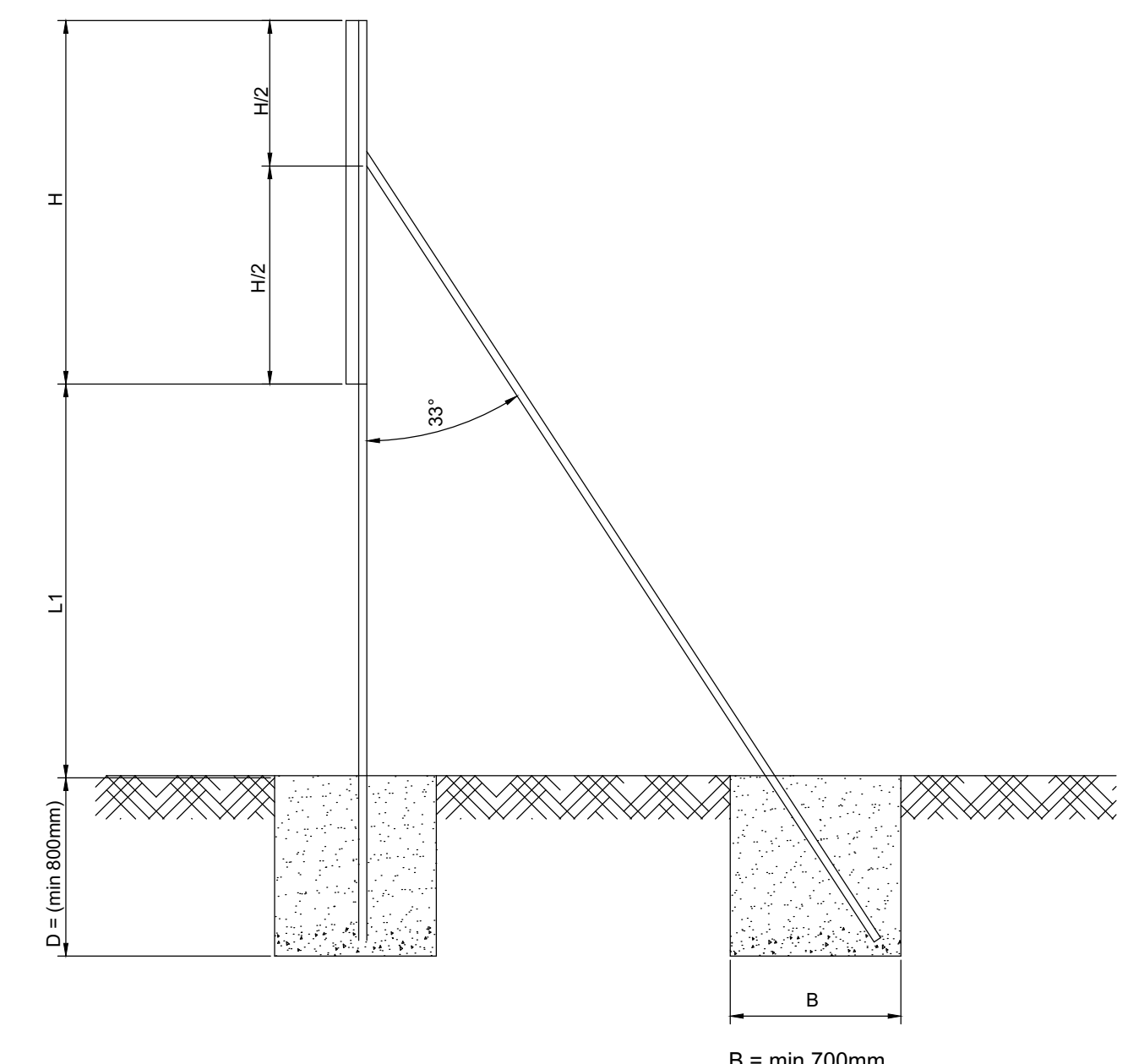

SIDE ELEVATION

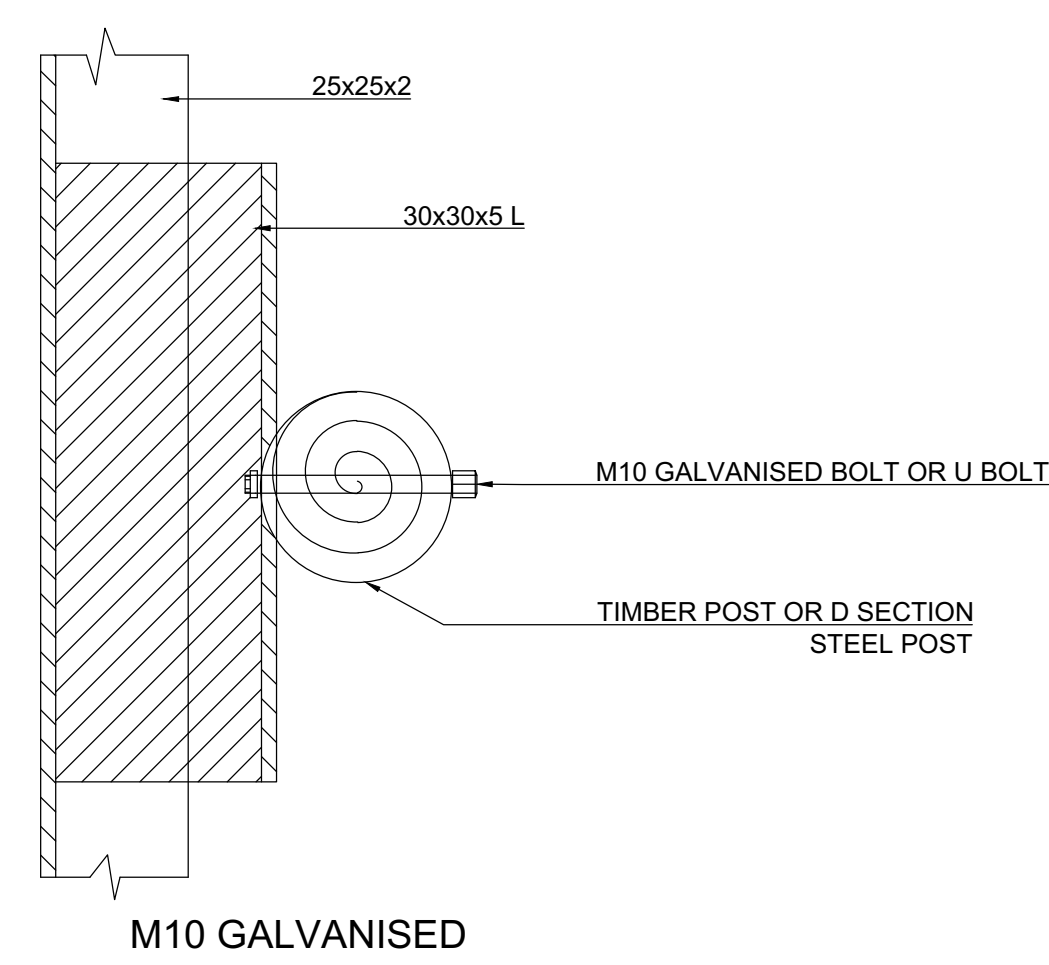

PLAN SECTION A-A

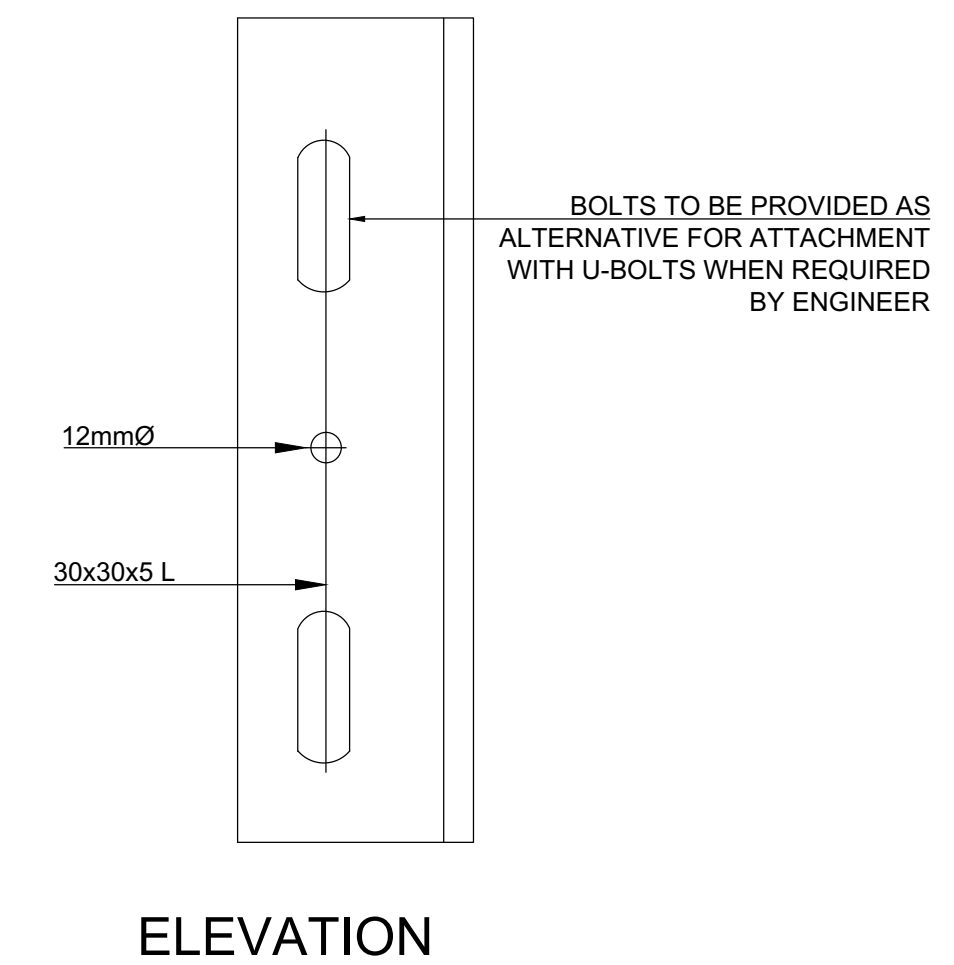

ERECTION BRACKET

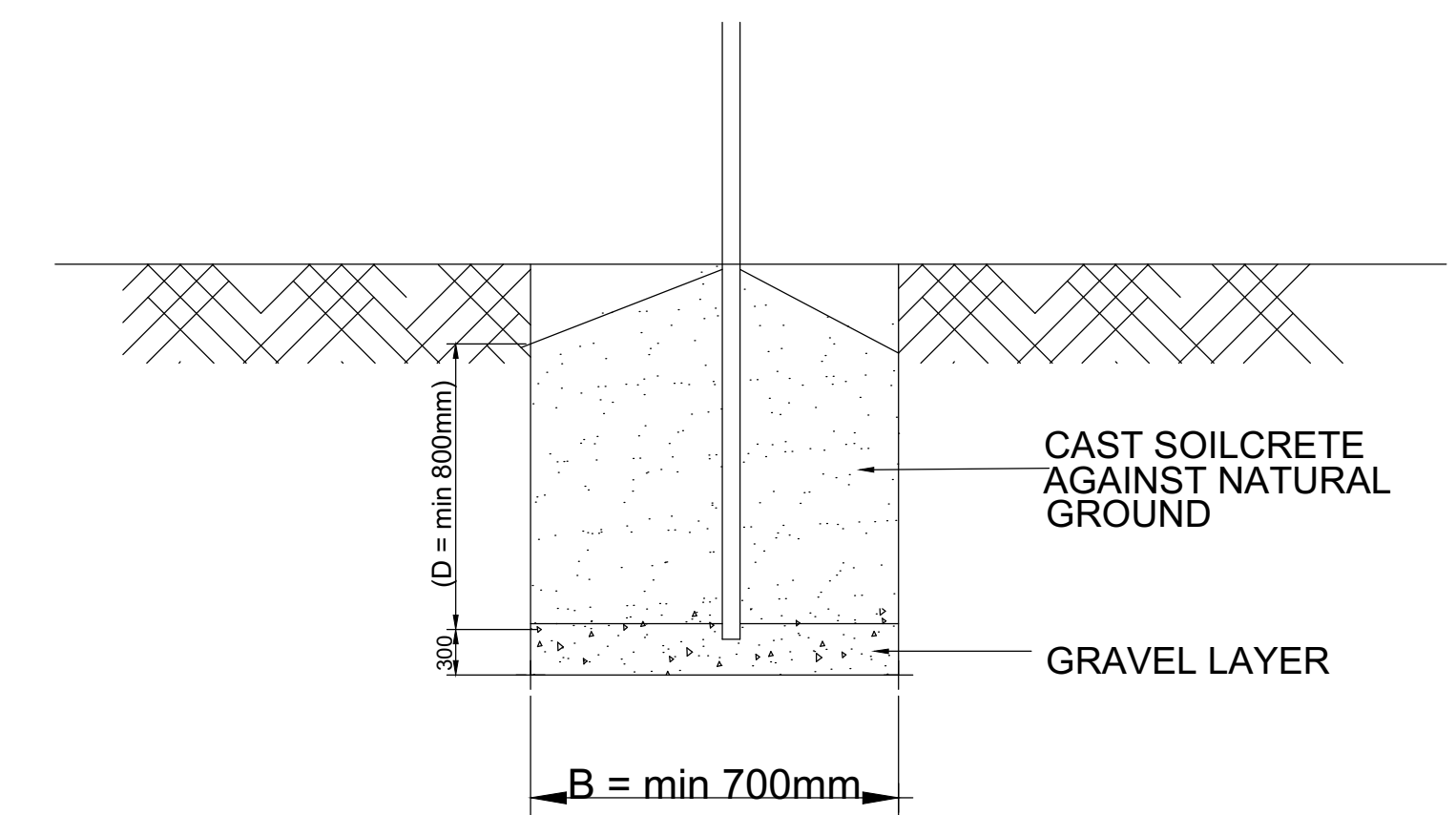

FOUNDATION DETAIL

TABLE 1

FOUNDATION AND SUPPORT SIZES

SIGN HEIGHT H (mm)	L (mm)	FREESTANDING SUPPORTS				BRACED SUPPORTS					
		FOUNDATION		POSTS		POSTS		TIMBER POLE		STAYS	
		BASE SIZE	BASE DEPTH	TIMBER POLE	Ø SECTION	BASE SIZE	BASE DEPTH	TIMBER POLE	BASE SIZE	BASE DEPTH	TIMBER POLE
1200 - 1800	< 2900	1200	800	140	78 X 2	700	500	80	700	500	80
	2900 - 3400	1300	800	140	100 X 4	700	500	80	700	500	80
	3400 - 5800	1450	900	180	100 X 4	700	600	80	700	600	120

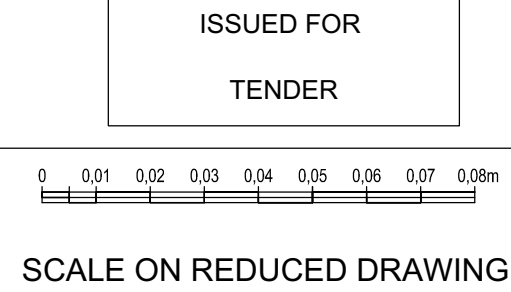

ISSUED FOR		DESIGNED BY	ATT	CAPRICORN DISTRICT MUNICIPALITY CAPRICORN DISTRICT MUNICIPALITY P.O. BOX 4100 POLOKWANE 0699 	SADC PROJECT CONSULTING & ORBITALS TRADING PROJECT JV UNIT 1 TYBACT PLACE YORK HOUSE WAERFALL PARK BEKKER ROAD MIDRAND 1685 	CLIENT	CAPRICORN DISTRICT MUNICIPALITY		ISSUED DATE	JUNE 2022		SHEET	1 OF 1				
TENDER		CHECKED BY	ATT			MUNICIPAL MANAGER	DATE	PROJECT		NAIRIN VILLAGE WATER SUPPLY		DRAWING SIZE	SCALE		DRAWING NUMBER	REV	
		DRAWN BY	N.S.			DRAWING TITLE		WATER		CONSULTANTS PROJECT NUMBER	ORB-NAIR-W74/2020/2021		NAIR-STD-01				0
No	DATE	CONSULT	DIR			EPWP BRANDED PROJECT NAME BOARD											

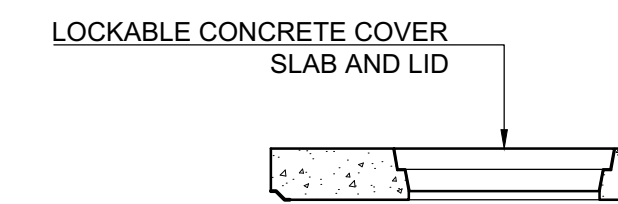
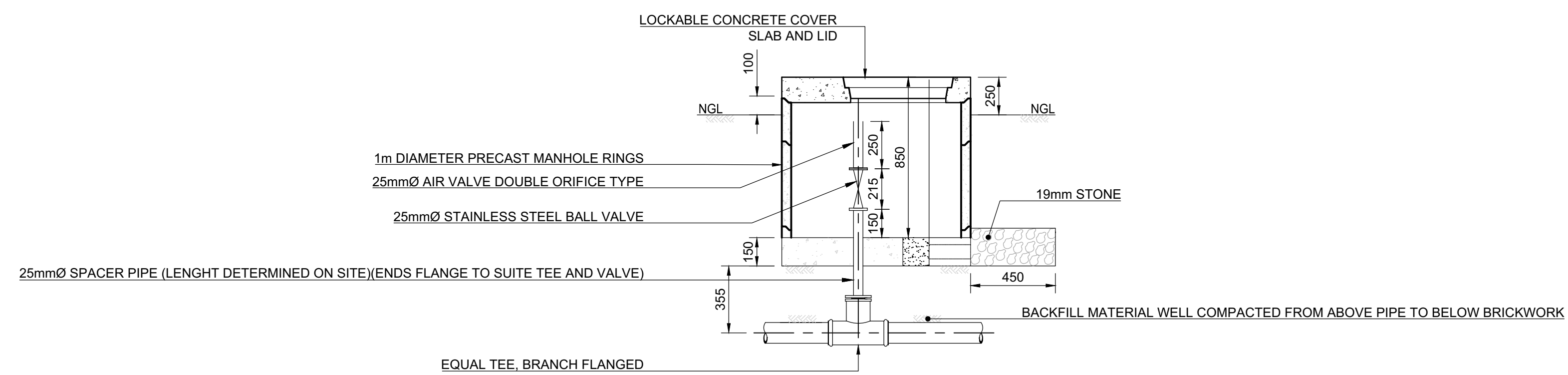

TYPE A: AIR VALVE CHAMBER FOR BELOW GROUND PIPE
SCALE 1:20

		ISSUED FOR TENDER		DESIGNED BY ATT	CAPRICORN DISTRICT MUNICIPALITY CAPRICORN DISTRICT MUNICIPALITY P.O. BOX 4100 POLOKWANE 0699	SADC PROJECT CONSULTING & ORBITALS TRADING PROJECT JV UNIT 1 TYBACT PLACE YORK HOUSE WAERFALL PARK BEKKER ROAD MIDRAND 1685	CLIENT CAPRICORN DISTRICT MUNICIPALITY	ISSUED DATE JUNE 2022	SHEET 1 OF 1	
		SCALE ON REDUCED DRAWING		CHECKED BY ATT			PROJECT NAIRIN VILLAGE WATER SUPPLY	DRAWING SIZE A1	SCALE 1:10	
				DRAWN BY N.S.			DISCIPLINE WATER	CONSULTANTS PROJECT NUMBER ORB-NAIR-W74/2020/201	DRAWING NUMBER NAIR-STD-02	REV 0
No	DATE	CONSULT	DIR	CHECKED BY ATT			DRAWING TITLE AIR VALVE CHAMBER			

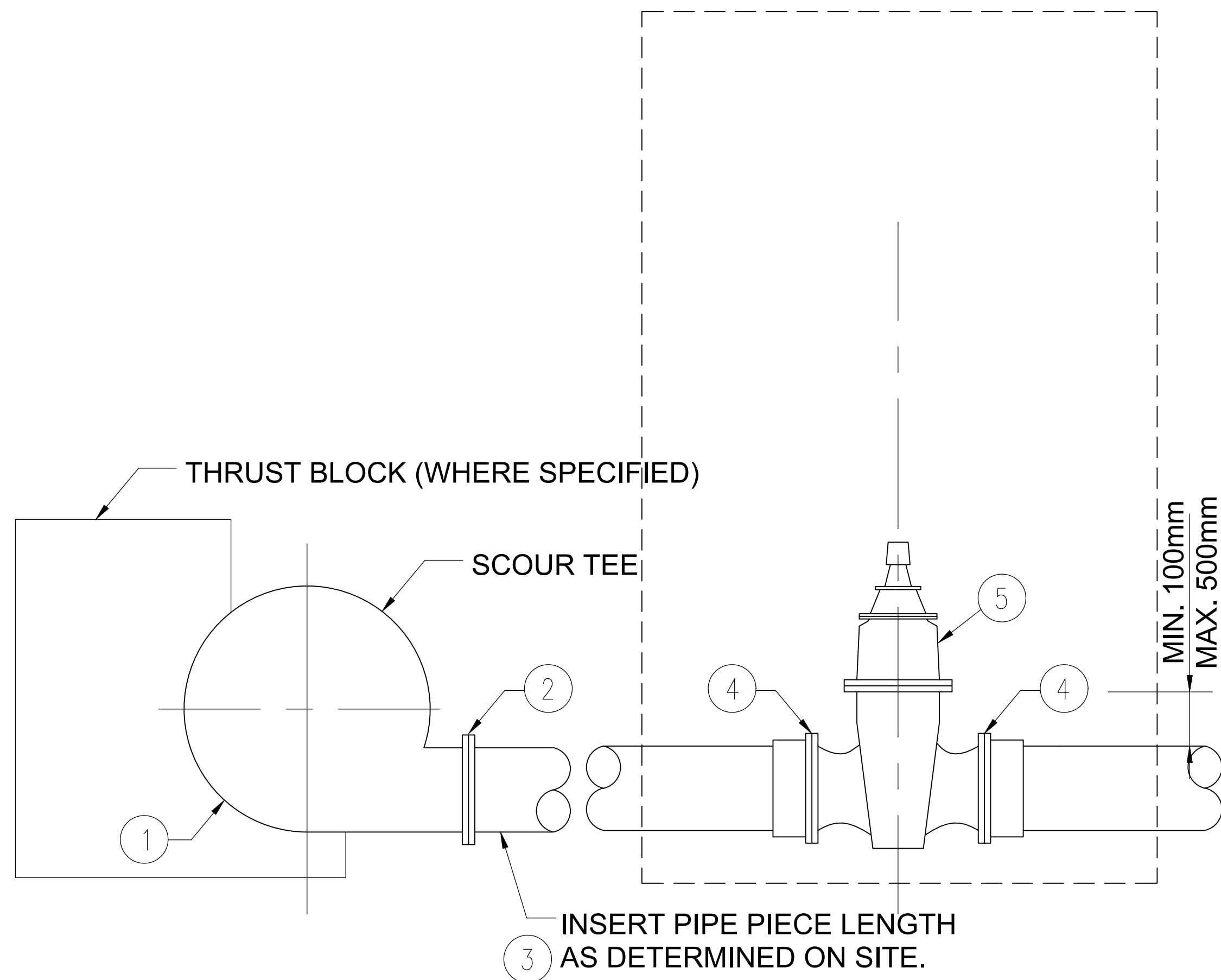

SECTION A-A
SCALE 1 : 10
SCOUR VALVE

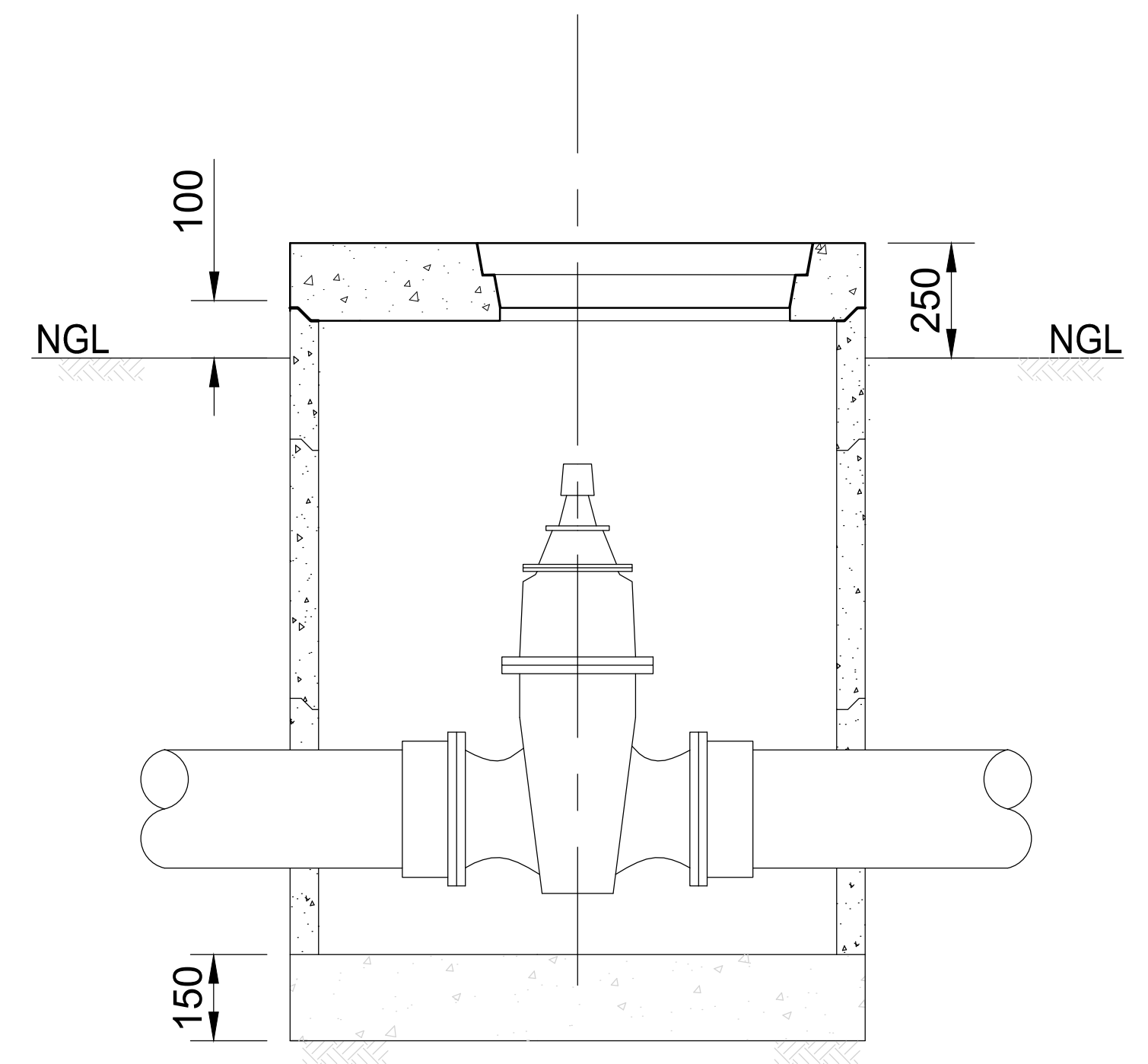

SCOUR VALVE CHAMBER

SCHEDULE OF FITTINGS	
1.	FLANGED SCOUR TEE
2.	2FLANGED ADAPTOR 100Ø TO SUIT STEEL TO uPVC
3.	uPVC INSERT PIPE TO SUIT SITE LENGTH 100Ø
4.	uPVC PLAN SOCKET 100Ø
5.	100Ø SOCKETED GATE WITH RISING SPINDLE

ISSUED FOR TENDER		DESIGNED BY ATT	CAPRICORN DISTRICT MUNICIPALITY CAPRICORN DISTRICT MUNICIPALITY P.O. BOX 4100 POLOKWANE 0699	SADC PROJECT CONSULTING & ORBITALS TRADING PROJECT JV UNIT 1 TYBACT PLACE YORK HOUSE WAERFALL PARK BEKKER ROAD MIDRAND 1685	CLIENT CAPRICORN DISTRICT MUNICIPALITY	ISSUED DATE JUNE 2022	SHEET 1 OF 1
SCALE ON REDUCED DRAWING 0 0.01 0.02 0.03 0.04 0.05 0.06 0.07 0.08m		CHECKED BY ATT			PROJECT NAIRIN VILLAGE WATER SUPPLY	DRAWING SIZE A1	SCALE 1:10
DRAWN BY N.S.		CHECKED BY ATT			DISCIPLINE WATER	CONSULTANTS PROJECT NUMBER ORB-NAIR-W74/2020/2021	DRAWING NUMBER NAIR-STD-03
No	DATE	CONSULT	DIR	SCALE ON REDUCED DRAWING	CHECKED BY ATT	DRAWING TITLE SCOUR VALVE CHAMBER	REV 0

TYPE A SOCKETED

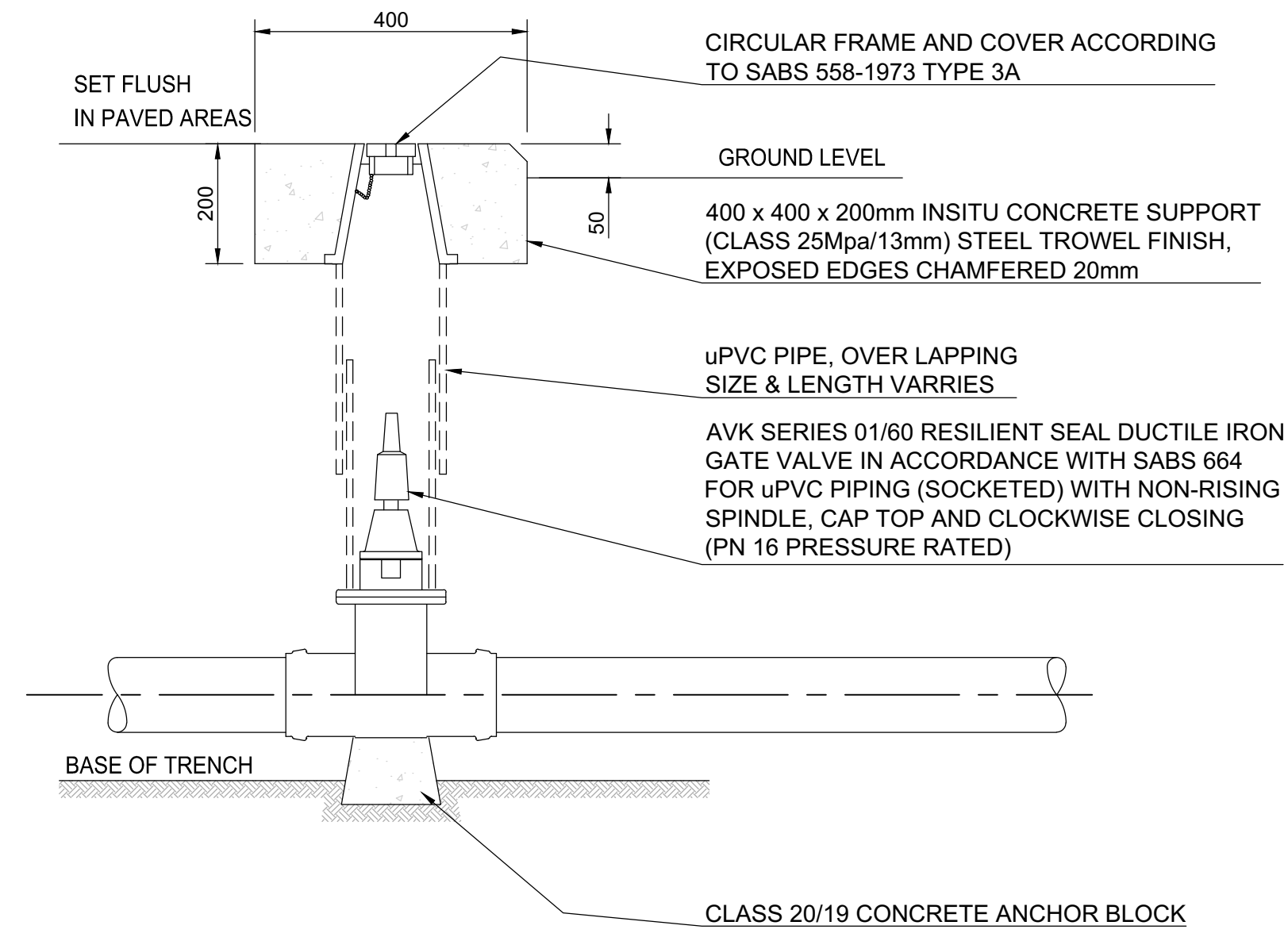

WATER LINE ISOLATING VALVE (50-160mmØ)
SCALE 1 : 10

TYPE A vjJOINTED

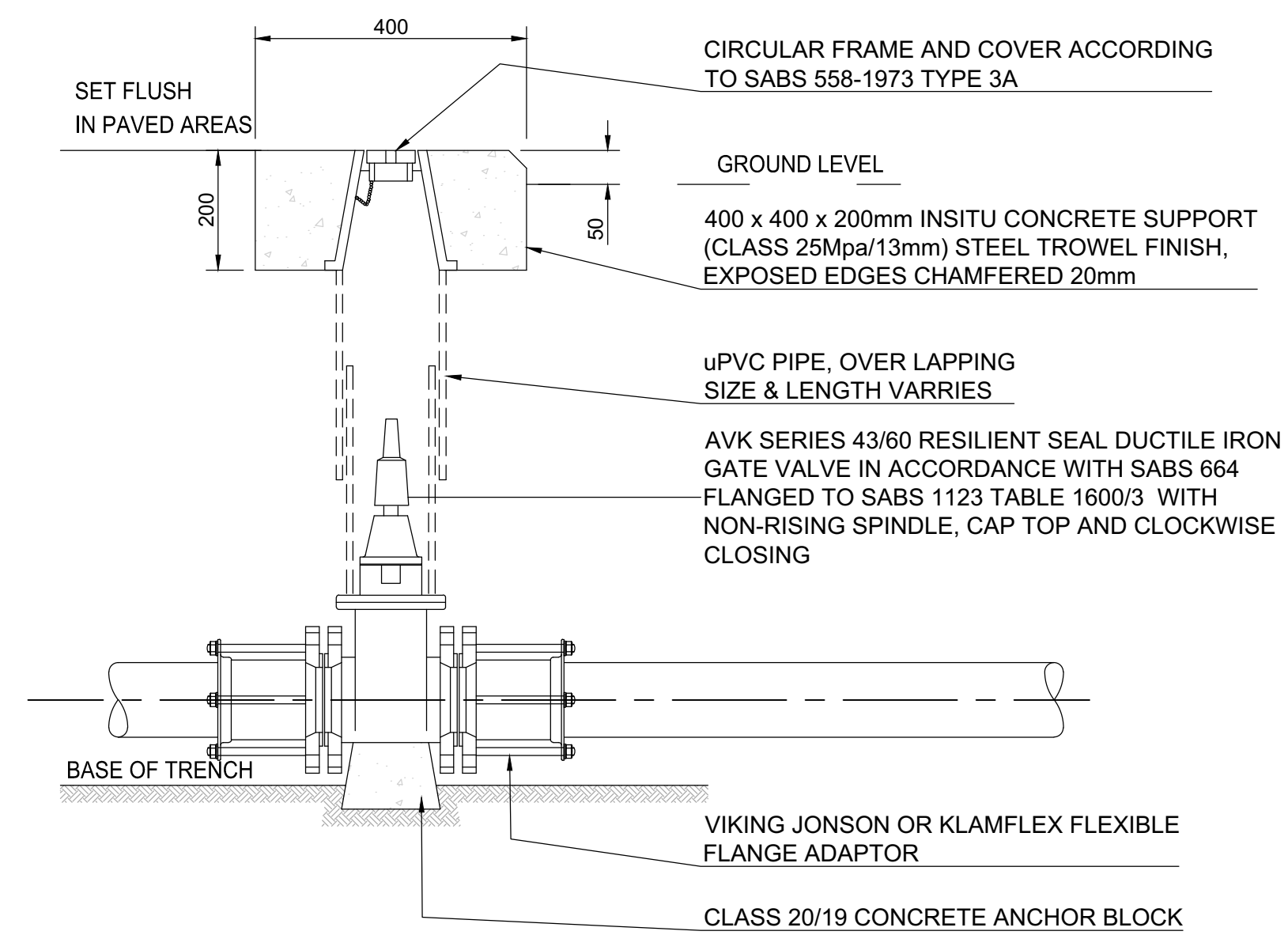

WATER LINE ISOLATING VALVE (65-100mmØ)
SCALE 1 : 10

- TYPE A FLANGED

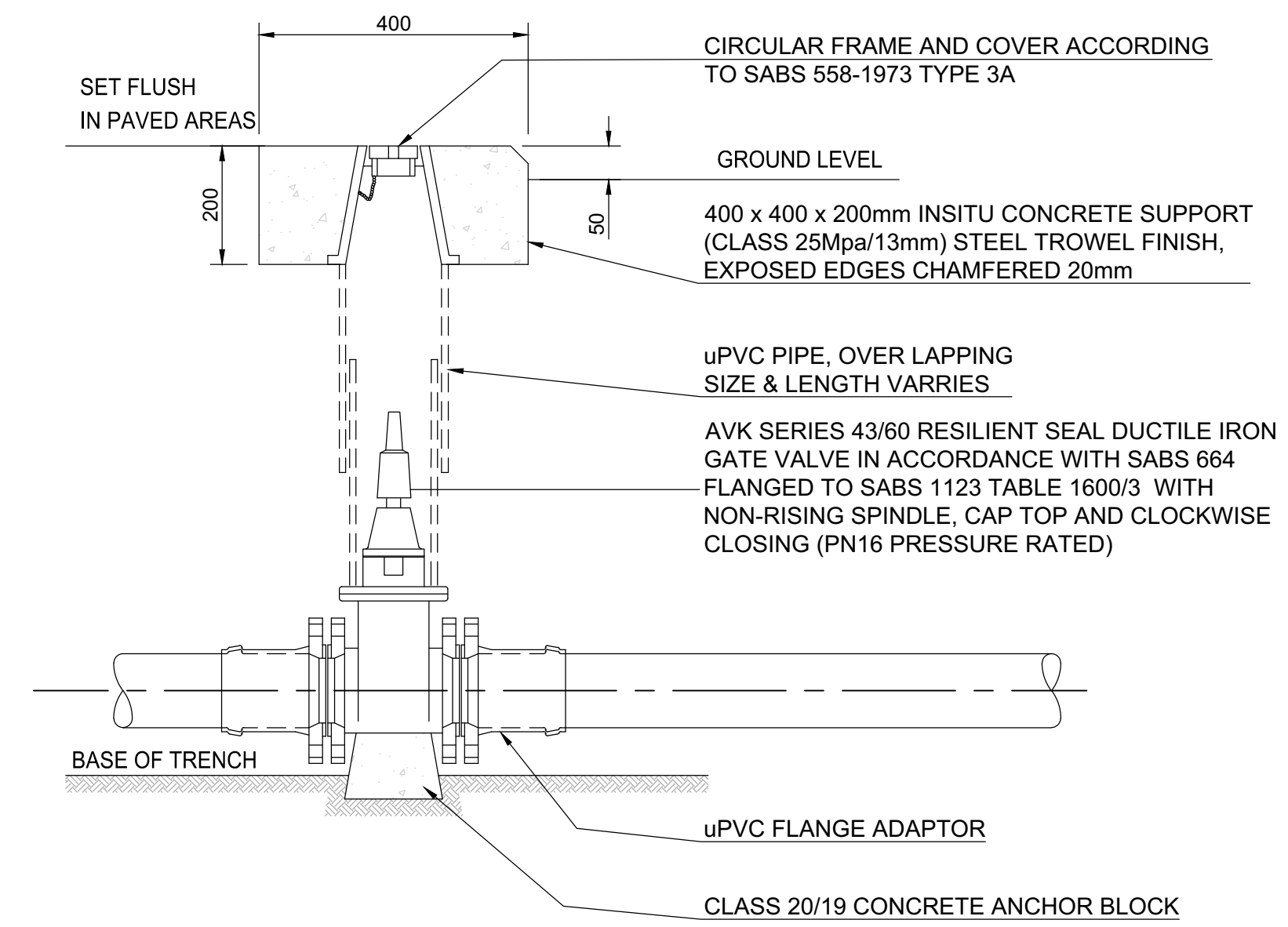

WATER LINE ISOLATING VALVE (50-160mmØ)
SCALE 1 : 10

ISSUED FOR TENDER		DESIGNED BY ATT	CAPRICORN DISTRICT MUNICIPALITY CAPRICORN DISTRICT MUNICIPALITY P.O. BOX 4100 POLOKWANE 0699	SADC PROJECT CONSULTING & ORBITALS TRADING PROJECT JV UNIT 1 TYBACT PLACE YORK HOUSE WAERFALL PARK BEKKER ROAD MIDRAND 1685	CLIENT CAPRICORN DISTRICT MUNICIPALITY	ISSUED DATE JUNE 2022	SHEET 1 OF 1
SCALE ON REDUCED DRAWING 0 0.01 0.02 0.03 0.04 0.05 0.07 0.09m		CHECKED BY ATT			PROJECT NAIRIN VILLAGE WATER SUPPLY	DRAWING SIZE A1	SCALE 1:10
No	DATE	CONSULT	DIR	CONSULTING ENGINEER	DATE	DISCIPLINE WATER	DRAWING NUMBER NAIR-STD-04
DRAWING TITLE ISOLATION VALVE CHAMBER						CONSULTANTS PROJECT NUMBER ORB-NAIR-W74/2020/201	REV 0

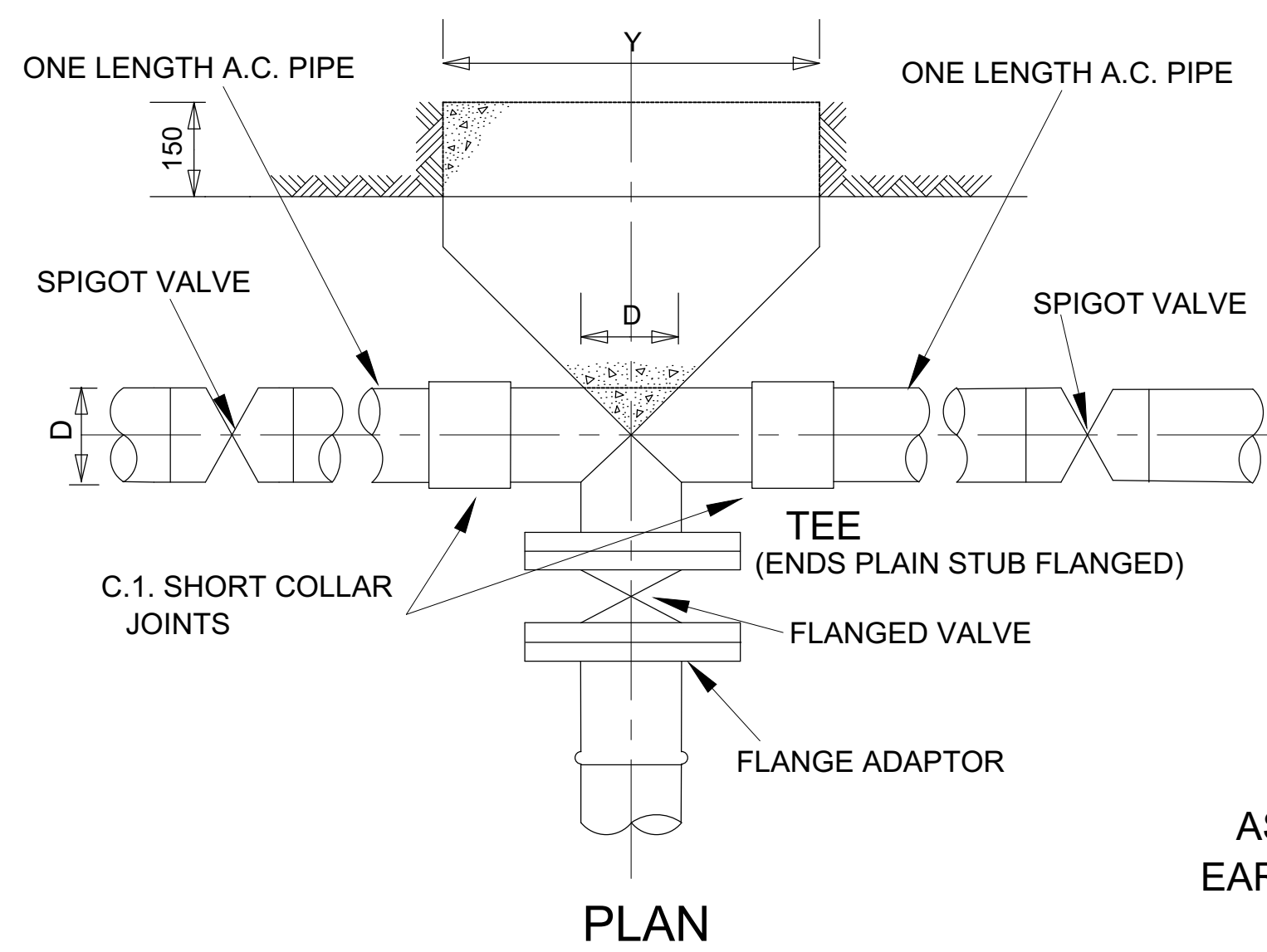

PLAN

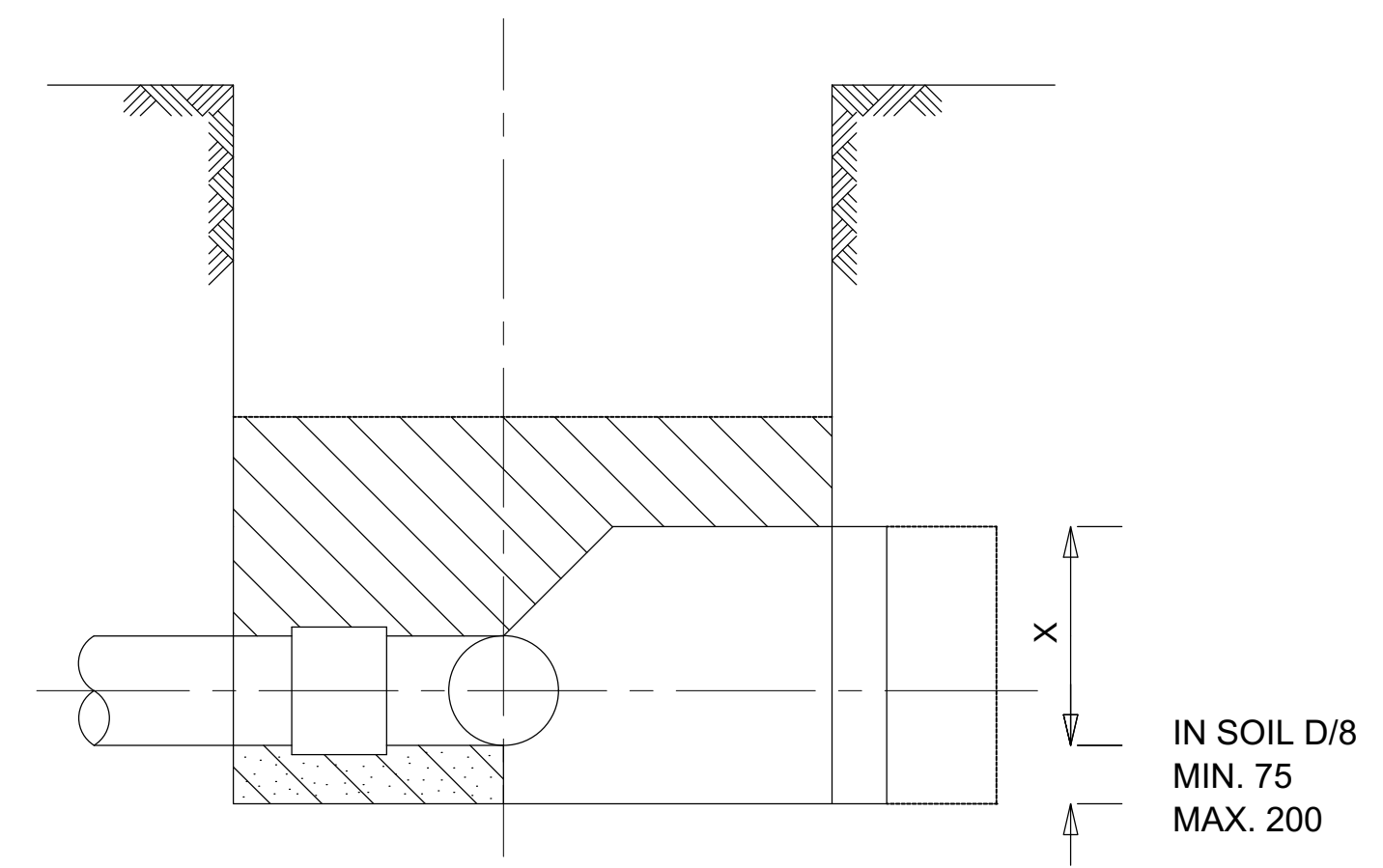
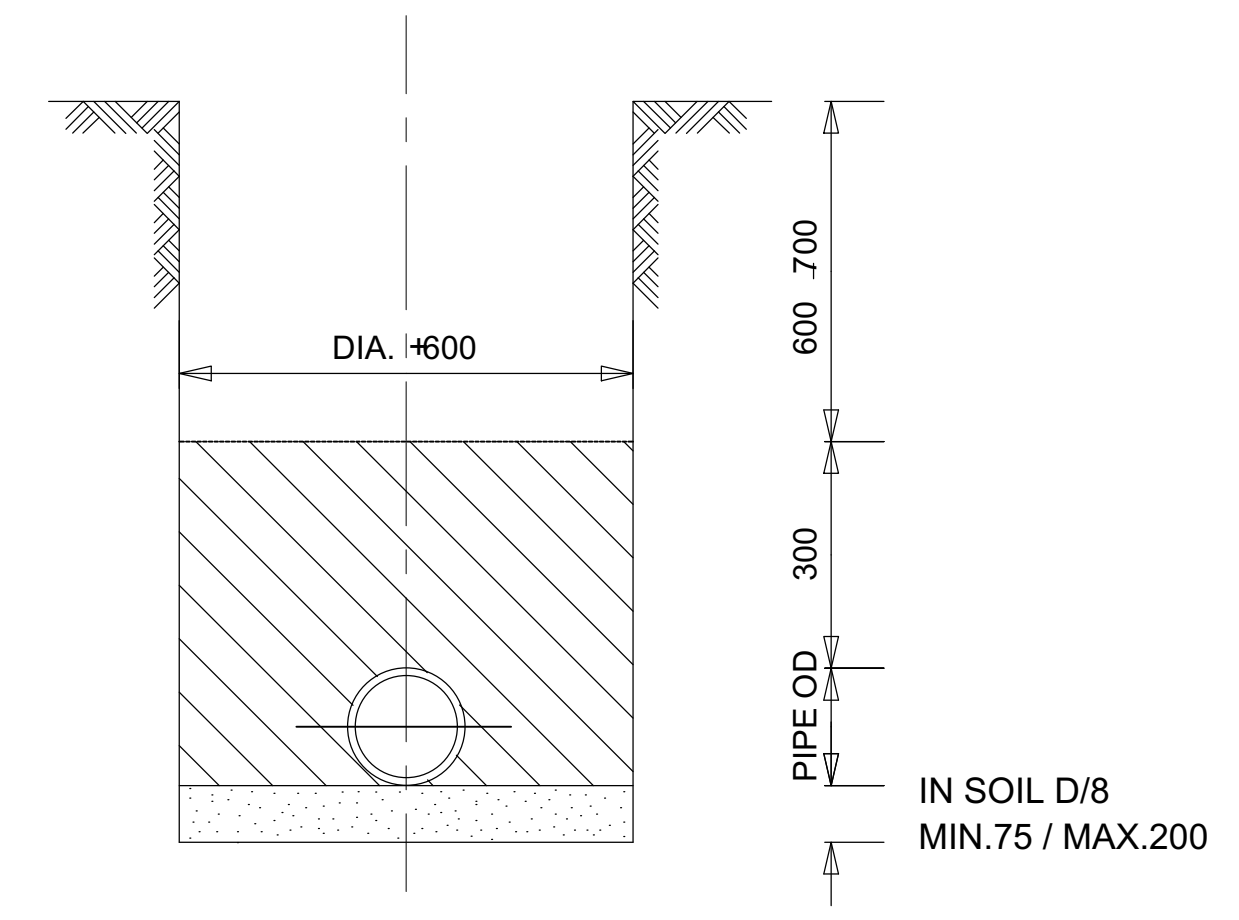

ELEVATION "A"

AS PER PART "DB" DEPT. SPECIFICATION FOR EARTHWORKS FOR PIPE TRENCHES. (CLASS "C")

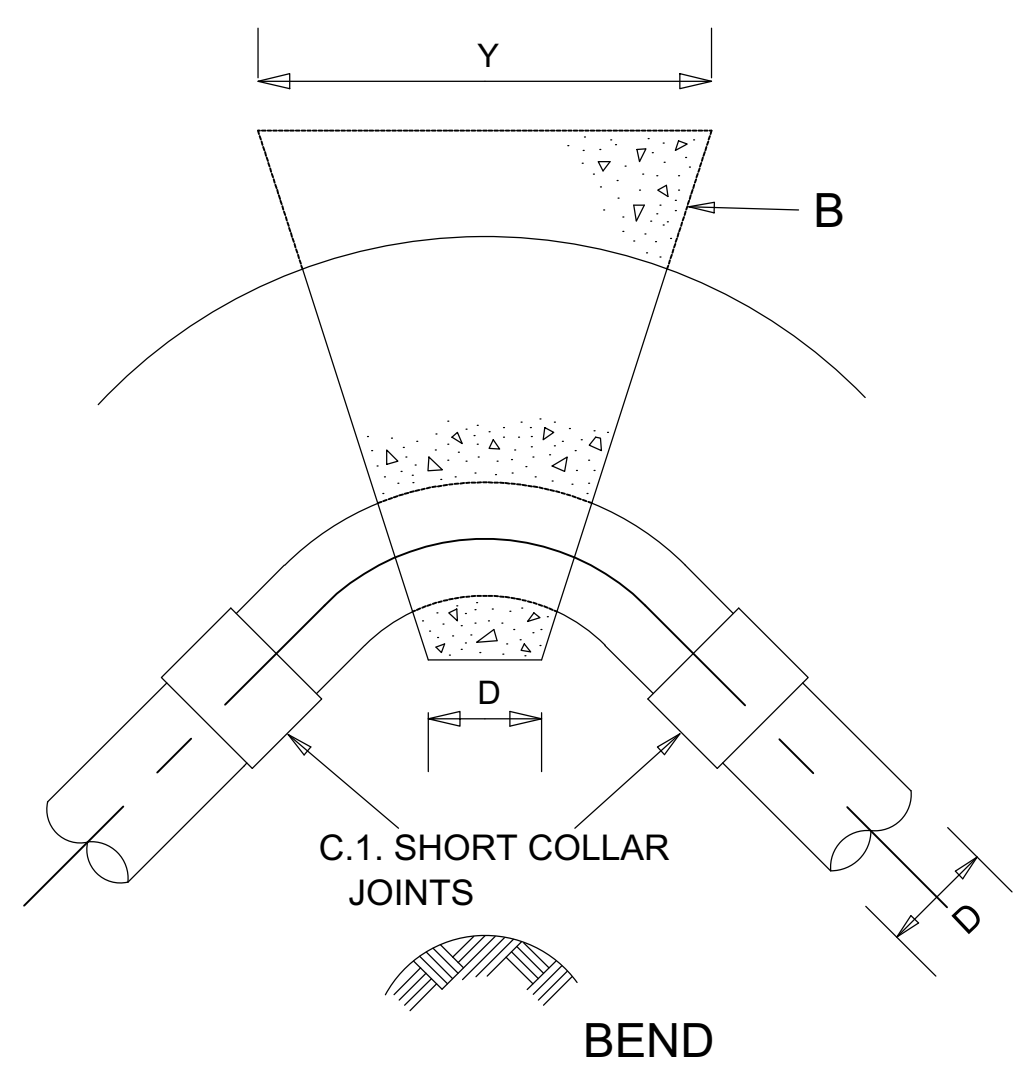

PLAN

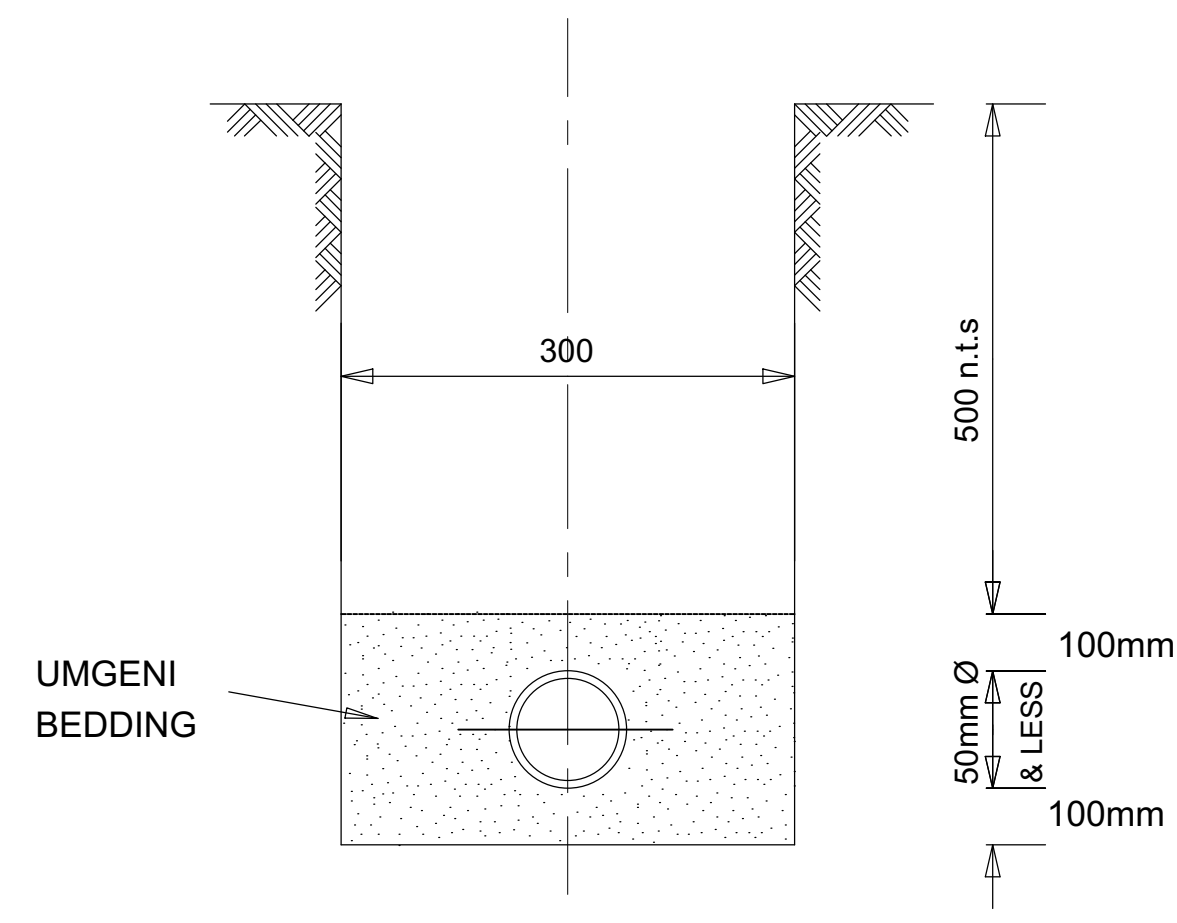

TRENCH DETAILS FOR 15 - 54mm Ø PIPEWORK

THRUST BLOCK SIZES (in mm)
in normal earth for heads of 120 m

PIPE SIZE	CAP	TEE (BRANCH)	90° 1/4 BEND	45° 1/8 BEND	22.5° 1/16 BEND	11.25° 1/32 BEND
75mm	200 x 200	200 x 200	250 x 300	200 x 250	200 x 200	200 x 200
100mm	200 x 400	200 x 400	300 x 500	250 x 300	200 x 200	200 x 200
150mm	300 x 600	300 x 600	500 x 600	350 x 500	300 x 300	200 x 250
200mm	400 x 800	400 x 800	600 x 900	400 x 800	300 x 500	250 x 300
250mm	600 x 800	600 x 800	900 x 900	600 x 800	400 x 600	300 x 300
300mm	700 x 1000	700 x 1000	1000 x 1300	700 x 1000	600 x 600	300 x 500
	X Y	X Y	X Y	X Y	X Y	X Y

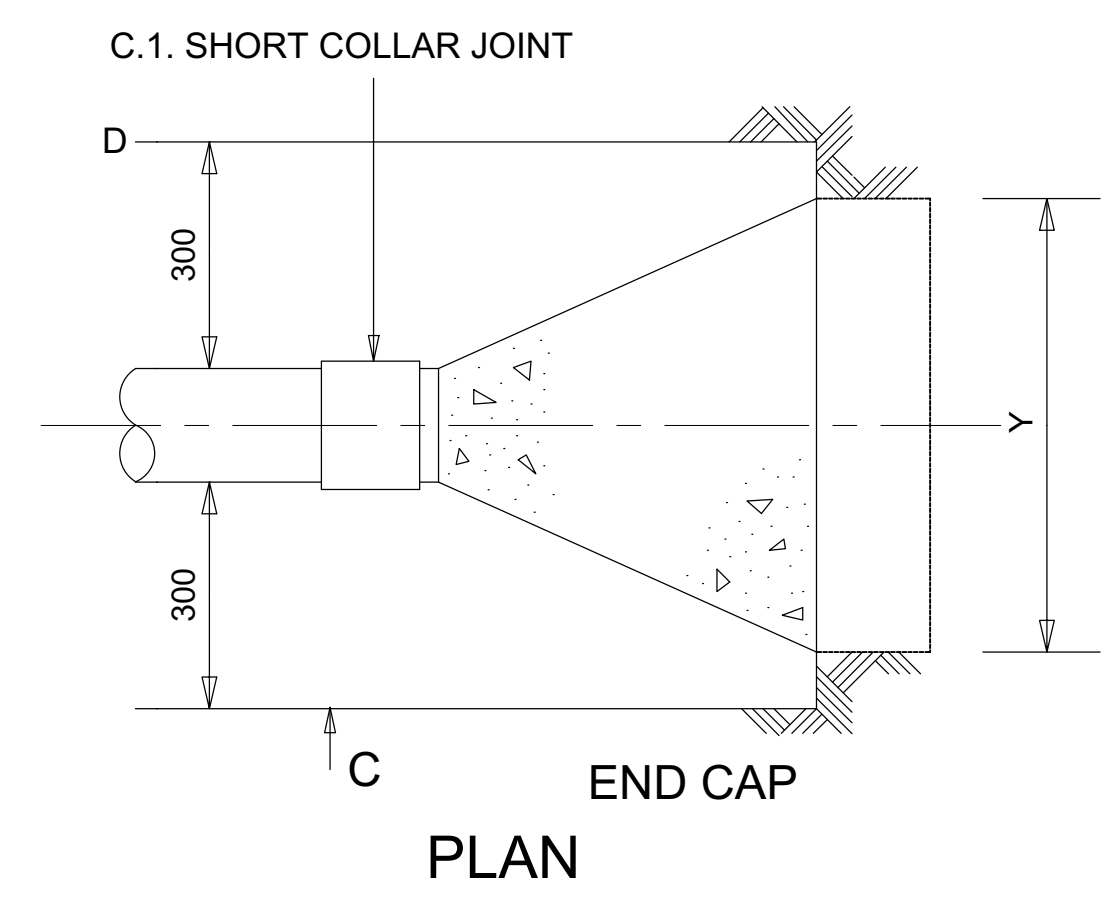

PLAN

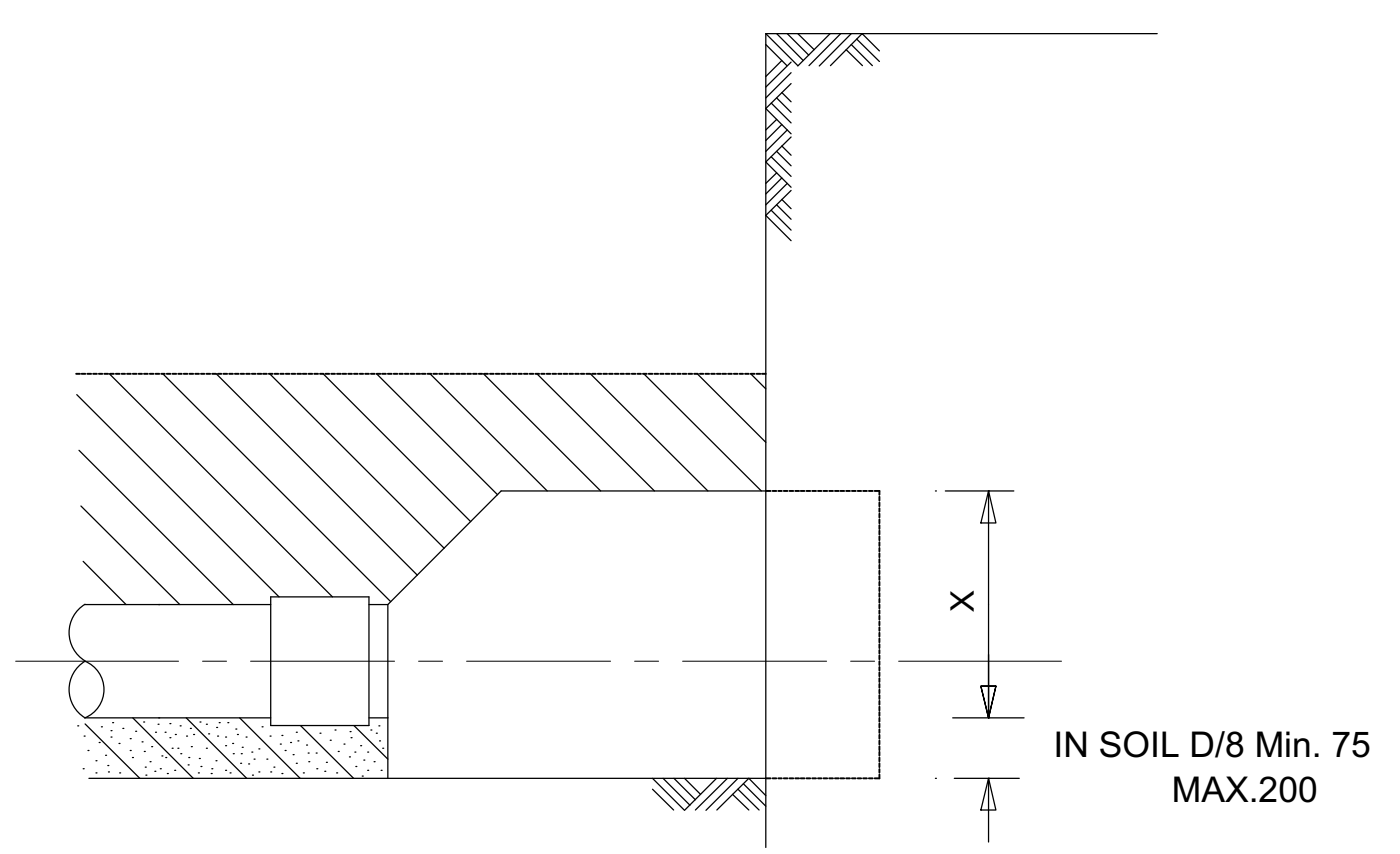

ELEVATION "C"

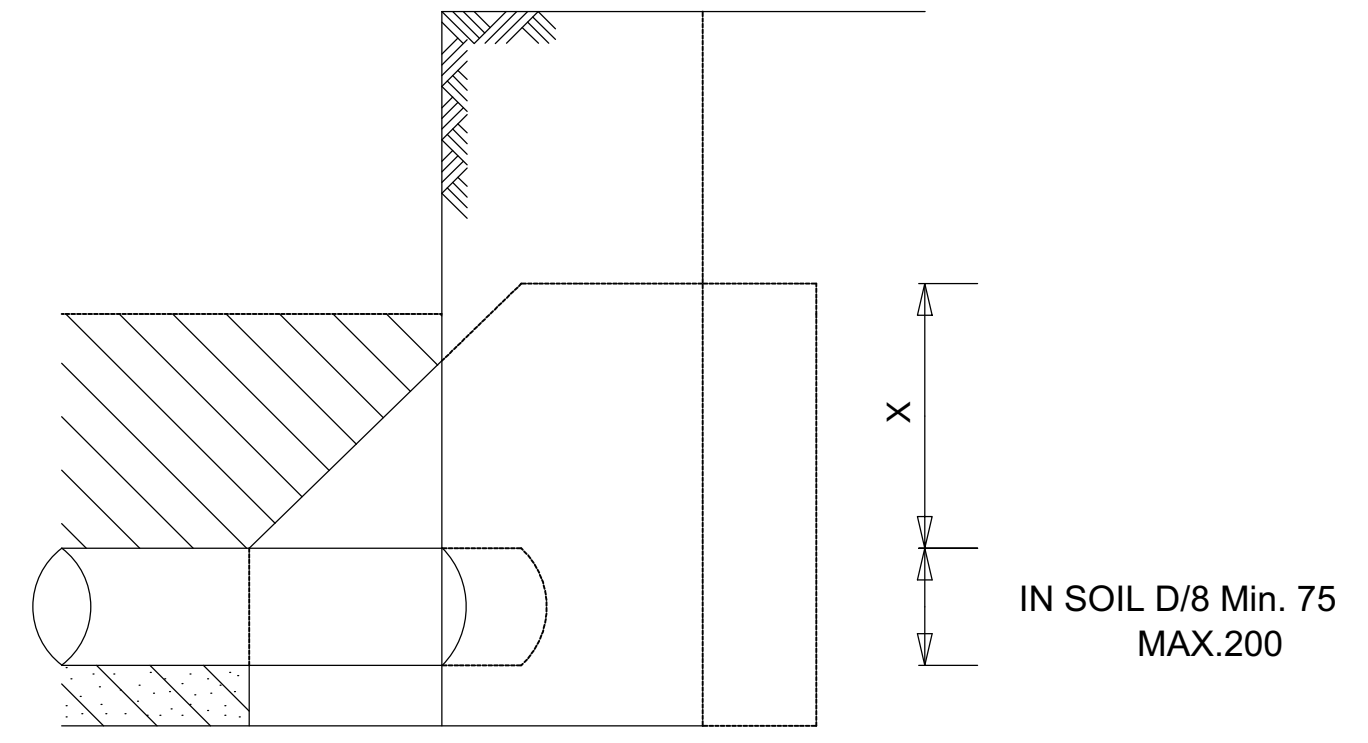

ELEVATION "B"

S = 200mm FOR PIPES WITH OD ≤ 620mm
 S = 450mm FOR PIPES WITH OD > 620mm

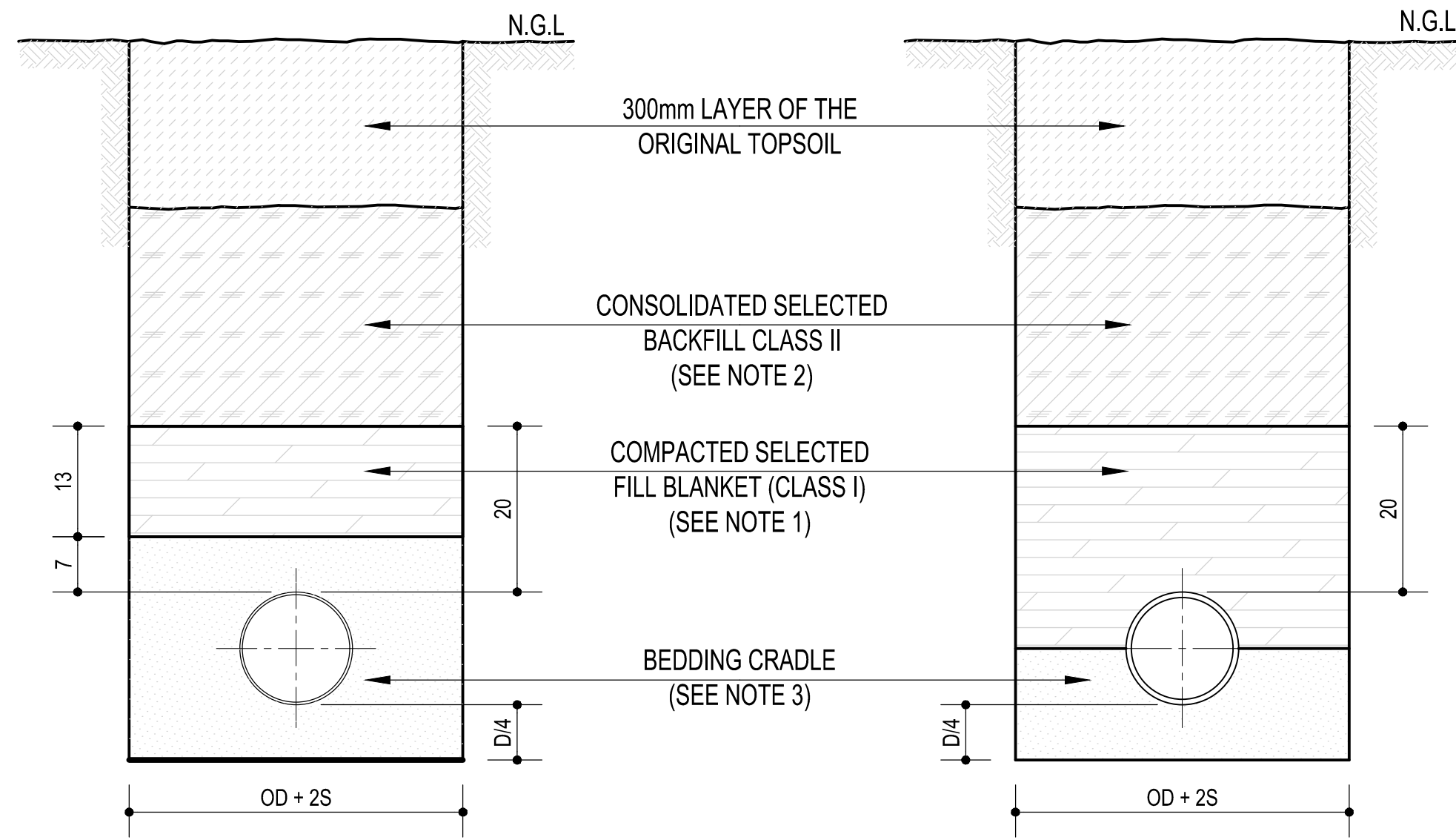

CLASS B BEDDING FOR FLEXIBLE PIPELINE
 SCALE 1:15

CLASS B BEDDING FOR RIGID PIPELINE
 SCALE 1:15

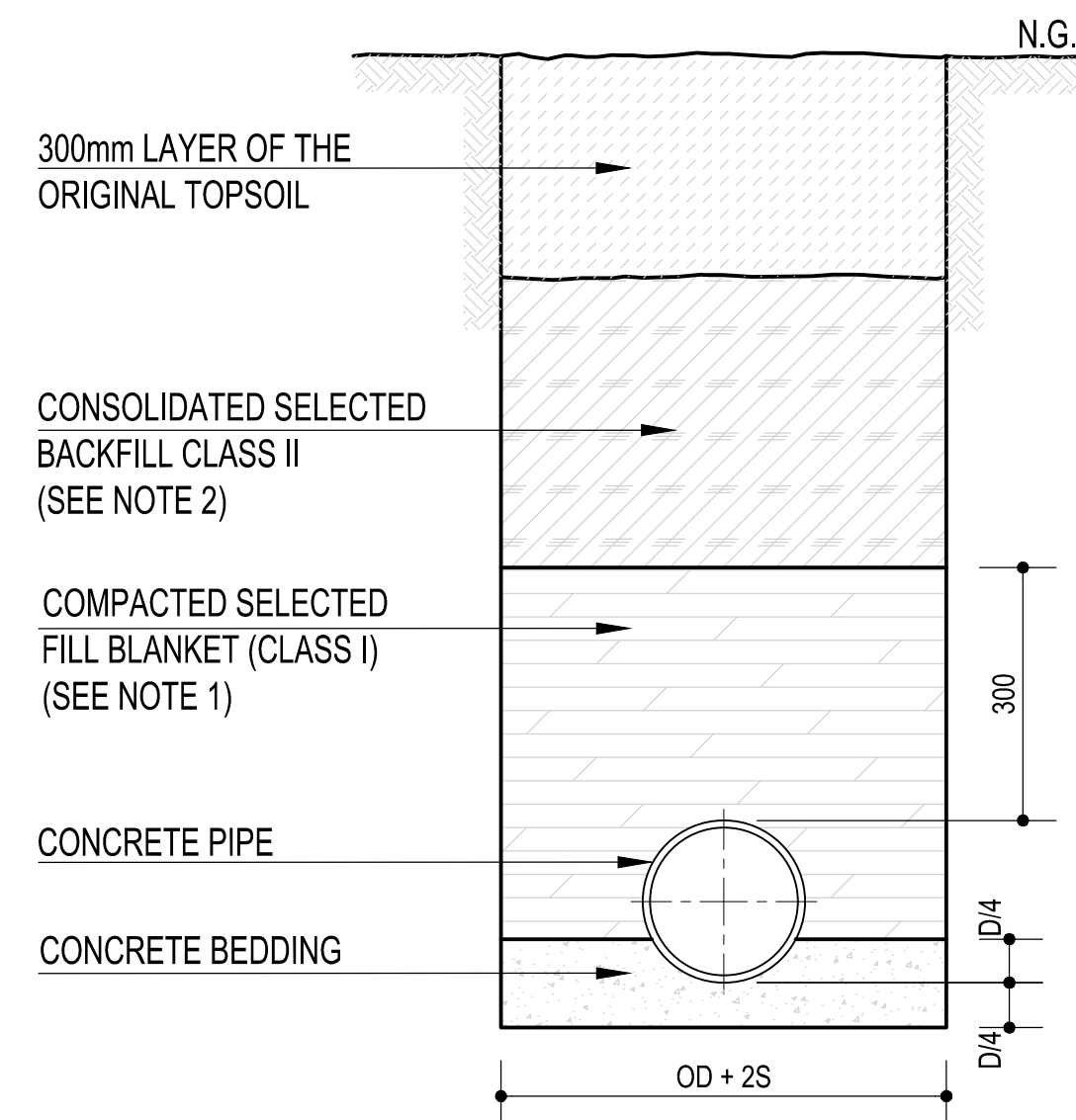

CLASS A BEDDING FOR RIGID PIPELINE
 SCALE 1:15

NOTES:

- 1) SELECTED BACKFILL CLASS I : IMPLIES APPROVED SELECTED MATERIAL FROM TRENCH EXCAVATION, FREE FROM STONES AND WITH AN OPTIMUM MOISTURE CONTENT.
- 2) SELECTED BACKFILL CLASS II : IMPLIES SELECTED BACKFILL FROM TRENCH EXCAVATION, WHICH SHALL NOT CONTAIN ANY STONES LARGER THAN 150mmØ.
- 3) CLASS B BEDDING CRADLE SHALL CONSIST OF AN APPROVED SELECTED GRAVEL MATERIAL WITH A PI NOT EXCEEDING 6, FREE FROM STONES EXCEEDING 20mm, ORGANIC MATTER AND LUMPS OF CLAY.
- 4) CLASS "A" BEDDING / ENCASING CONCRETE BETWEEN JOINTS SHALL BE CARRIED OUT IN ONE CONTINUOUS OPERATION USING CLASS 20/19 CONCRETE.
- 5) FLEXIBLE JOINTS MUST BE PROVIDED, AT EACH PIPE JOINT IN A CLASS "A" CONCRETE BEDDING / ENCASING, WITH A 12mm THICK SOFTBOARD PLACED VERTICALLY FOR THE ENTIRE CONCRETE AREA. PIPE JOINTS MUST BE SEALED WITH WET CLAY TO PREVENT SLUSH FROM PENETRATING THE JOINT.
- 6) EXCEPT FOR THE 300mm BACKFILL ON THE TOP OF THE PIPE, THE BALANCE OF THE TRENCH MAY BE BACKFILLED WHEN THE CLASS "A" BEDDING / ENCASING HAS OBTAINED THE COMPRESSIVE STRENGTH OF 15MPa.

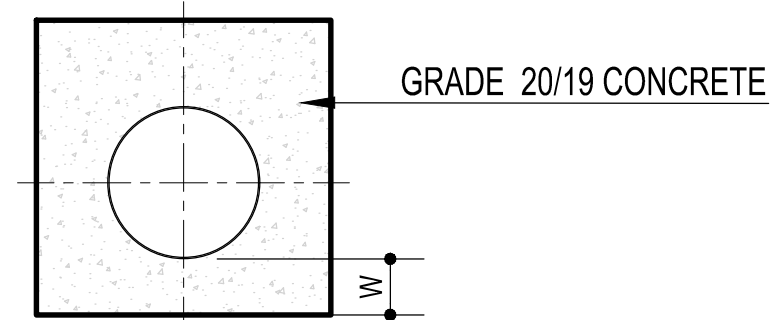

CONCRETE ENCASING:
 W = 100mm FOR PIPES ≤ 225mm NOMINAL DIAMETER.
 W = 150mm FOR PIPES BETWEEN 225mm AND 450mm NOMINAL DIAMETER.

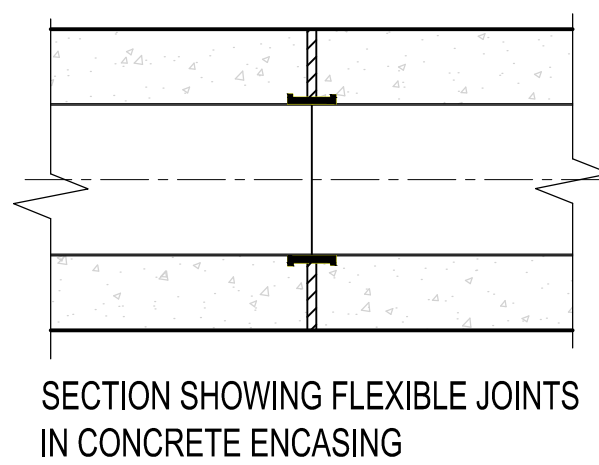

PIPE ENCASING DETAIL
 SCALE 1:15

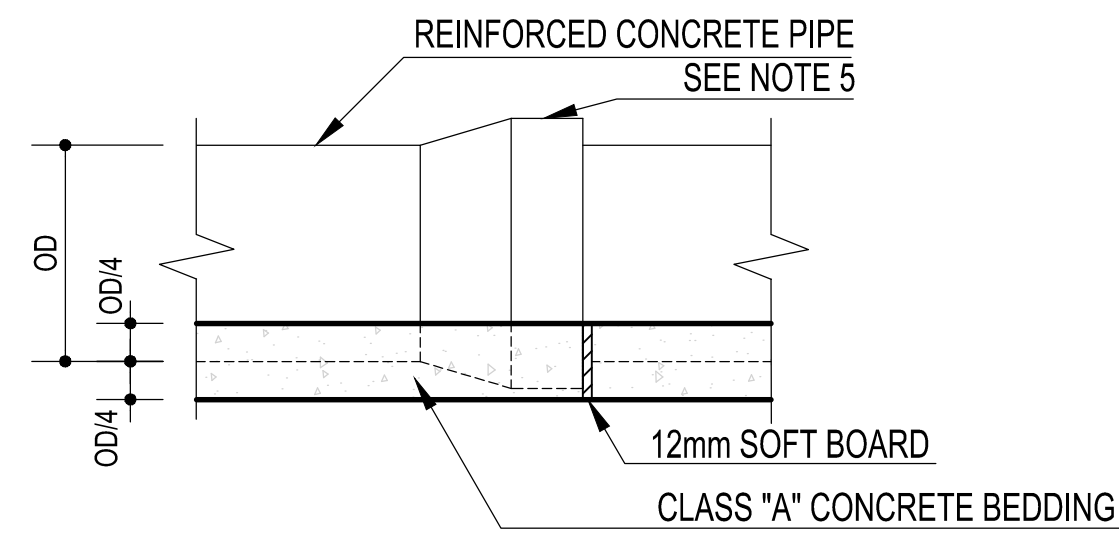

SIDE ELEVATION
 NTS

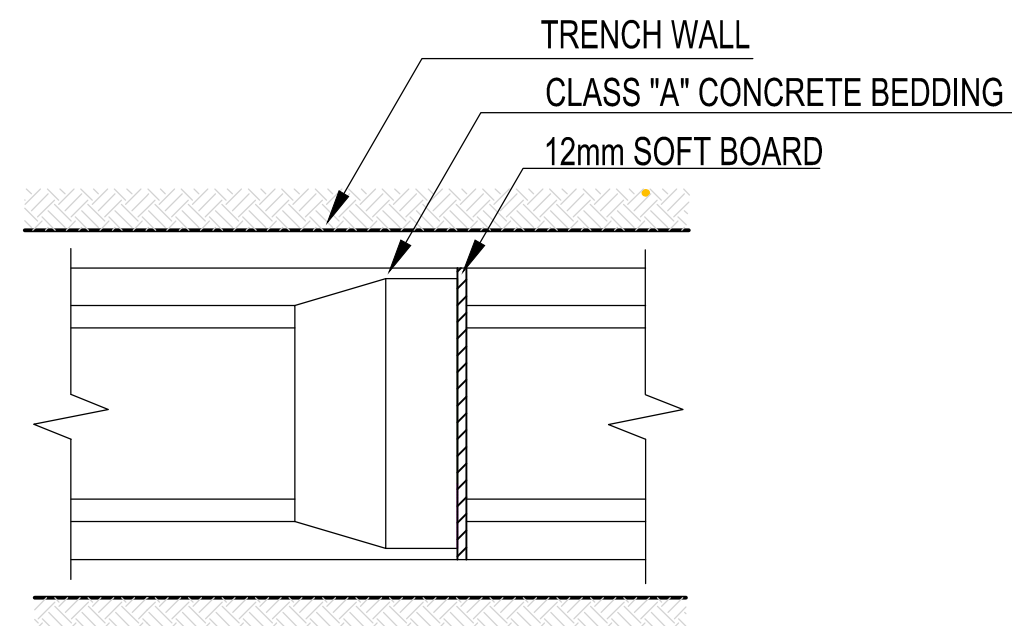

PLAN
 NTS
CLASS "A" BEDDING DETAIL

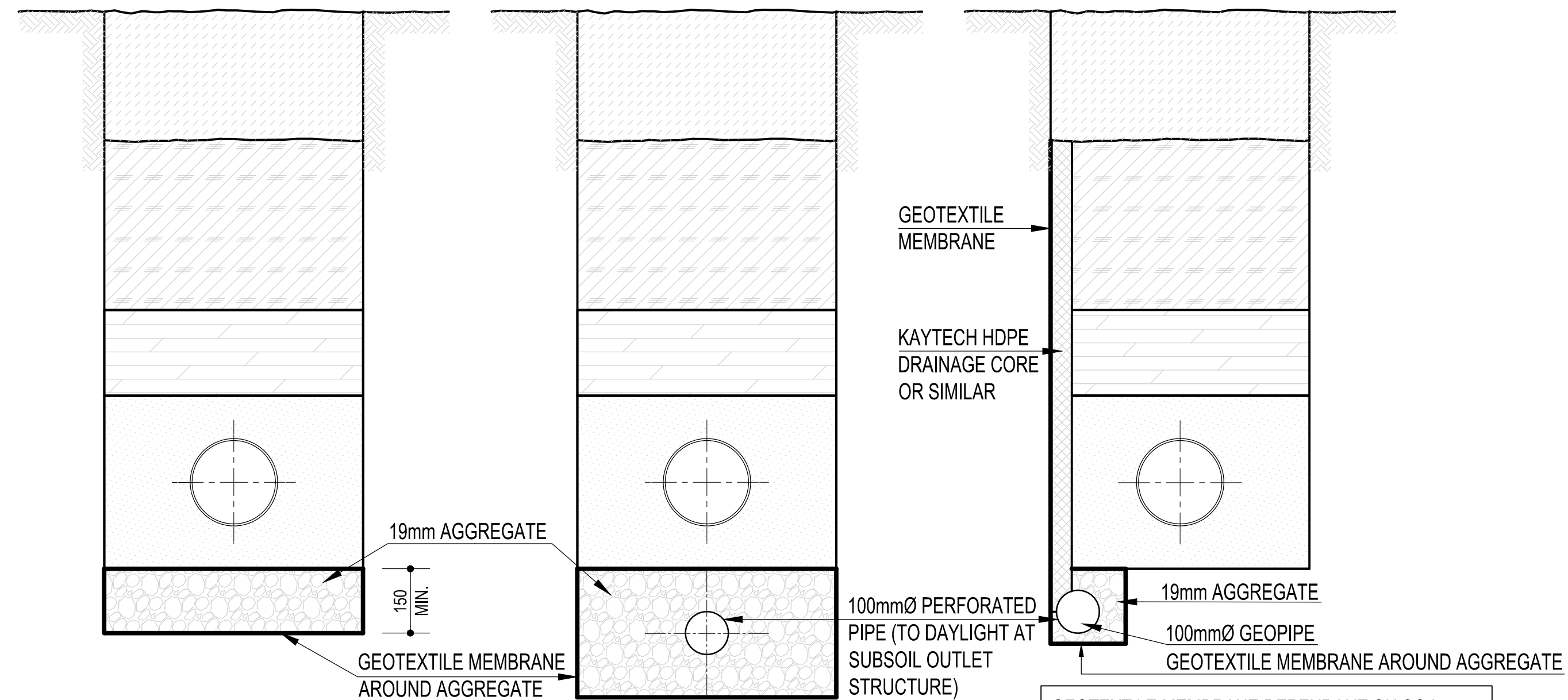

TYPICAL SUBSURFACE DRAINS
 SCALE 1:15

ISSUED FOR TENDER		DESIGNED BY ATT	CAPRICORN DISTRICT MUNICIPALITY CAPRICORN DISTRICT MUNICIPALITY P.O. BOX 4100 POLOKWANE 0699		SADC PROJECT CONSULTING & ORBITALS TRADING PROJECT JV UNIT 1 TYBACT PLACE YORK HOUSE WAERFALL PARK BEKKER ROAD MIDRAND 1685		CLIENT CAPRICORN DISTRICT MUNICIPALITY	ISSUED DATE JUNE 2022	SHEET 1 OF 1		
SCALE ON REDUCED DRAWING 0 0.01 0.02 0.03 0.04 0.05 0.07 0.09m		CHECKED BY ATT	CAPRICORN DISTRICT MUNICIPALITY		MUNICIPAL MANAGER _____ DATE _____		PROJECT NAIRIN VILLAGE WATER SUPPLY	DRAWING SIZE A1	SCALE AS SHOWN		
		DRAWN BY N.S.	CAPRICORN DISTRICT MUNICIPALITY		CONSULTING ENGINEER _____ DATE _____		DISCIPLINE WATER	CONSULTANTS PROJECT NUMBER ORB-NAIR-W74/2020/201		DRAWING NUMBER NAIR-STD-07	REV 0
		CHECKED BY ATT	CAPRICORN DISTRICT MUNICIPALITY				DRAWING TITLE BEDDING DETAILS				

LEGEND

ITEM

- 1.1 WATER SUPPLY MAIN
- 1.2 SADDLE TO SUIT WATER MAIN WITH 25mmØ THREADED NIPPLE
- 1.3 25mmØ PLASSON FEMALE ADAPTOR
- 1.4 25mmØ HDPE PIPE OF SAME CLASS AS WATER MAIN
- 1.5 25mmØ PLASSON MALE ADAPTOR
- 1.6 25ND GMS FEMALE EQUAL TEE
- 1.7 25ND x 20ND GMS REDUCING NIPPLE
- 1.8 20Ø PLASSON FEMALE ADAPTOR
- 1.9 20Ø HDPE PIPE OF SAME CLASS AS WATER MAIN
- 1.10 20mmØ PLASSON MALE ADAPTOR
- 1.11 20ND GMS FEMALE ELBOW
- 1.12 20ND GMS THREADED PIPE
- 1.13 KENT DOMESTIC METER UNIT COMPLETE WITH HDPE BOX DN20 V100 ELSTER-KENT METER, STRAINER AND ISOLATING VALVE
- 1.14 20ND GMS FEMALE EQUAL TEE WITH ONE END PLUGGED
- 1.15 1000mm LONG TANDARD "Y" SHAPED FENCE POST, WITH STEEL STRAPS, CAST INTO CONCRETE
- 1.16 20ND GMS FEMALE ELBOW
- 1.17 20Ø BIP HOSE TAP

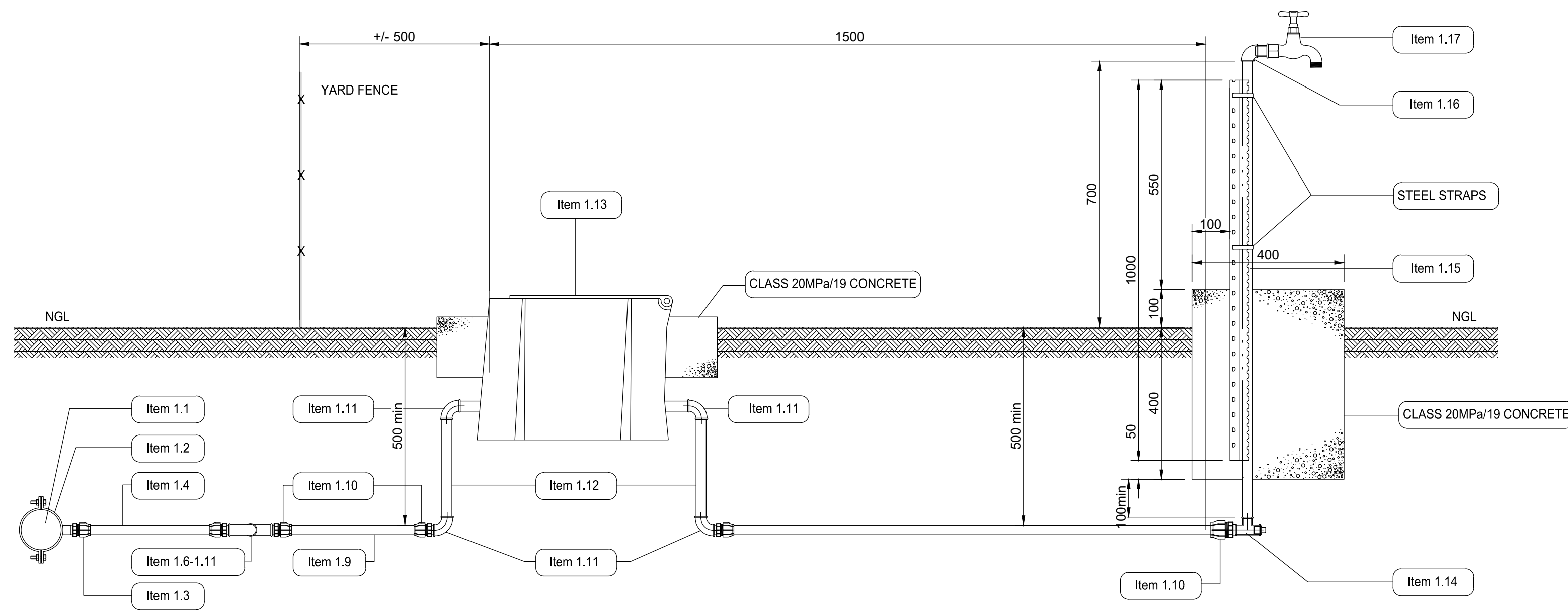
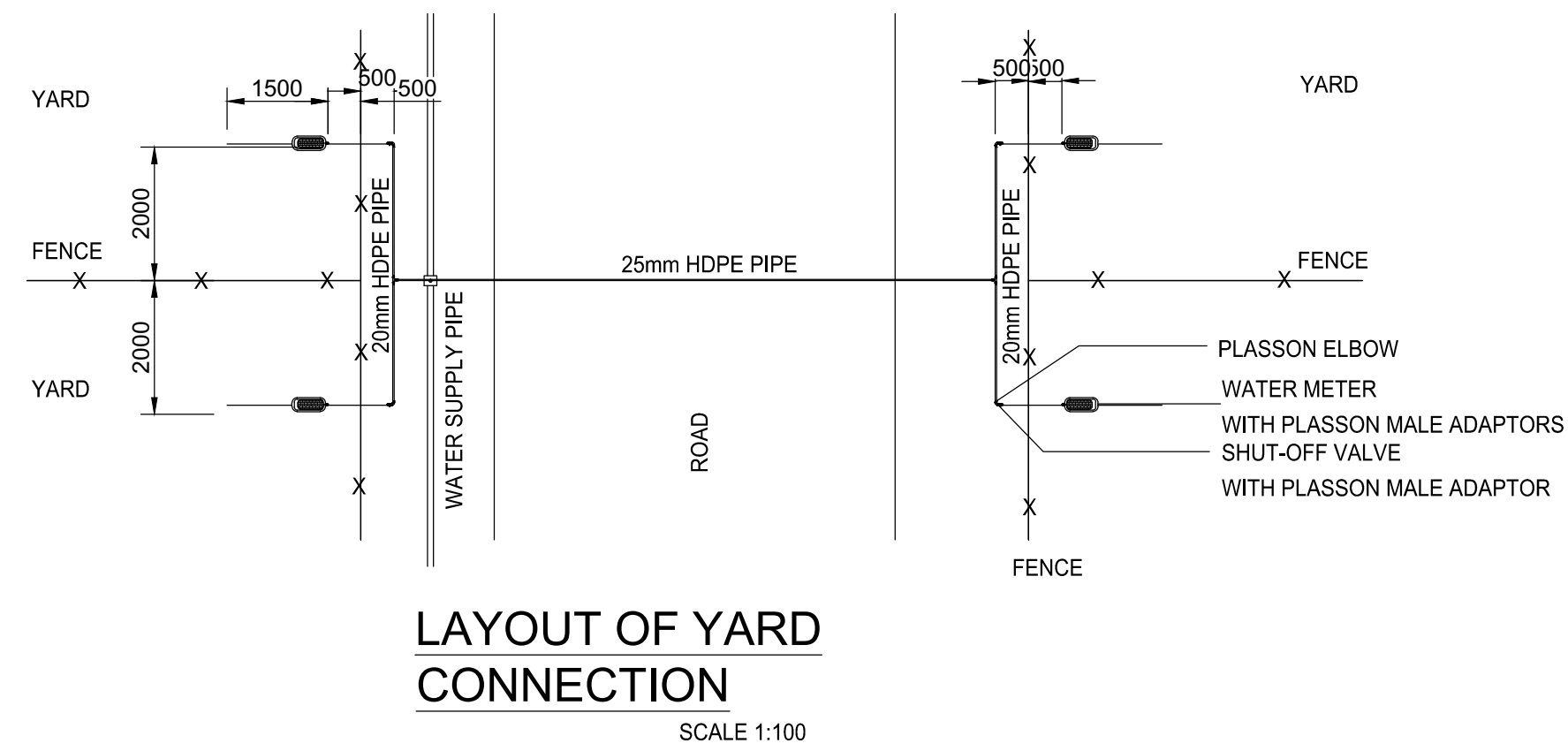

TYPICAL YARD CONNECTION DETAIL
SCALE 1:10

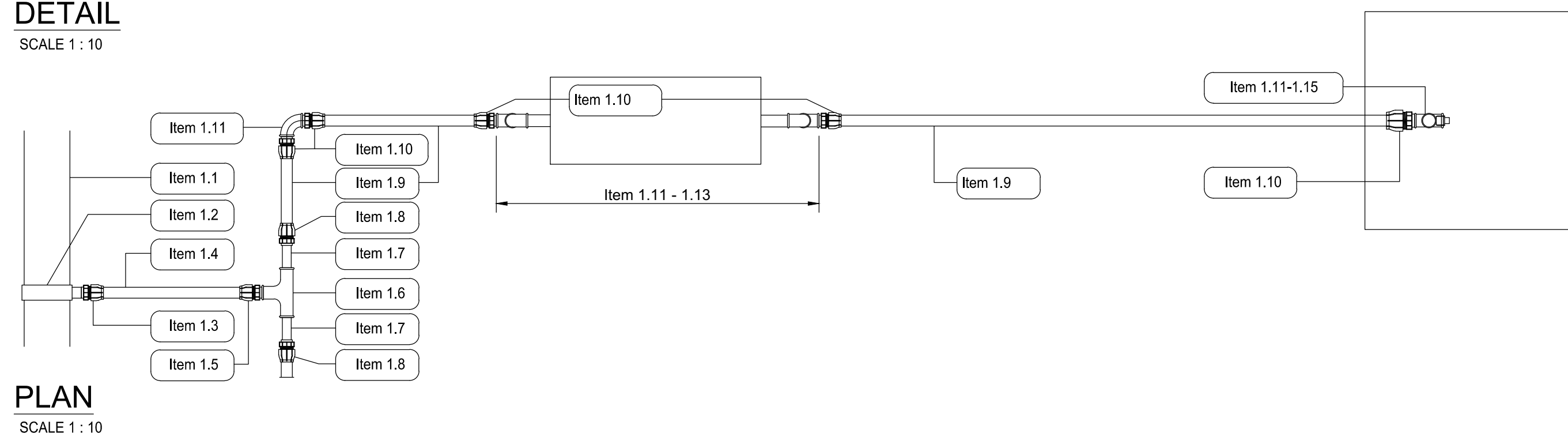

ISSUED FOR TENDER		DESIGNED BY ATT	ATT	CAPRICORN DISTRICT MUNICIPALITY CAPRICORN DISTRICT MUNICIPALITY P.O. BOX 4100 POLOKWANE 0699	SADC PROJECT CONSULTING & ORBITALS TRADING PROJECT JV UNIT 1 TYBACT PLACE YORK HOUSE WAERFALL PARK BEKKER ROAD MIDRAND 1685	CLIENT CAPRICORN DISTRICT MUNICIPALITY	ISSUED DATE JUNE 2022	SHEET 1 OF 1
SCALE ON REDUCED DRAWING 0 0.01 0.02 0.03 0.04 0.05 0.07 0.09m		CHECKED BY ATT	ATT			PROJECT NAIRIN VILLAGE WATER SUPPLY	DRAWING SIZE A1	SCALE 1:10
		DRAWN BY N.S.	N.S.			DISCIPLINE WATER	CONSULTANTS PROJECT NUMBER ORB-NAIR-W74/2020/201	DRAWING NUMBER NAIR-STD-08
No	DATE	CONSULT	DIR	CHECKED BY ATT		DRAWING TITLE STANDPIPE AND YARD CONNECTION DETAILS		REV 0

TYPICAL PROFILE DUTY PALISADE FENCING			
MAIN POST	RAILS	PALES	CONCRETE
3m OVERALL LENGTH	2m OVERALL LENGTH	2.4m OVERALL LENGTH	3MPa MIN AT 28 DAYS STRENGTH
80mm TAPERING TO 140mm FRONT FACE	55mm THICKNESS	80mm TAPERING TO 100mm FRONT FACE	12mm MIN COVER AS PER SABS 1372-1983
225mm DEPTH	1150mm WIDTH	75mm DEPTH	
3 x Y8 x 2.9 LONG STEEL BARS	4 x R5.6 x 1.95m LONG STEEL BARS	3 x 4mm x 2.35m LONG STEEL BARS	
		2 x 8mm GALVANIZED HOOK BOLTS	

DESIGN REVIEW: 10 PALE PER 2m CONCRETE PALISADE SYSTEM HOOK BOLTS SECURE PALES TO RAILS. SPACES ENSURES UNIFORM AND ADEQUATE COVER OF THE REINFORCING STEEL. ALL COMPONENTS ARE MANUFACTURED TO STRICT QUALITY STANDARDS

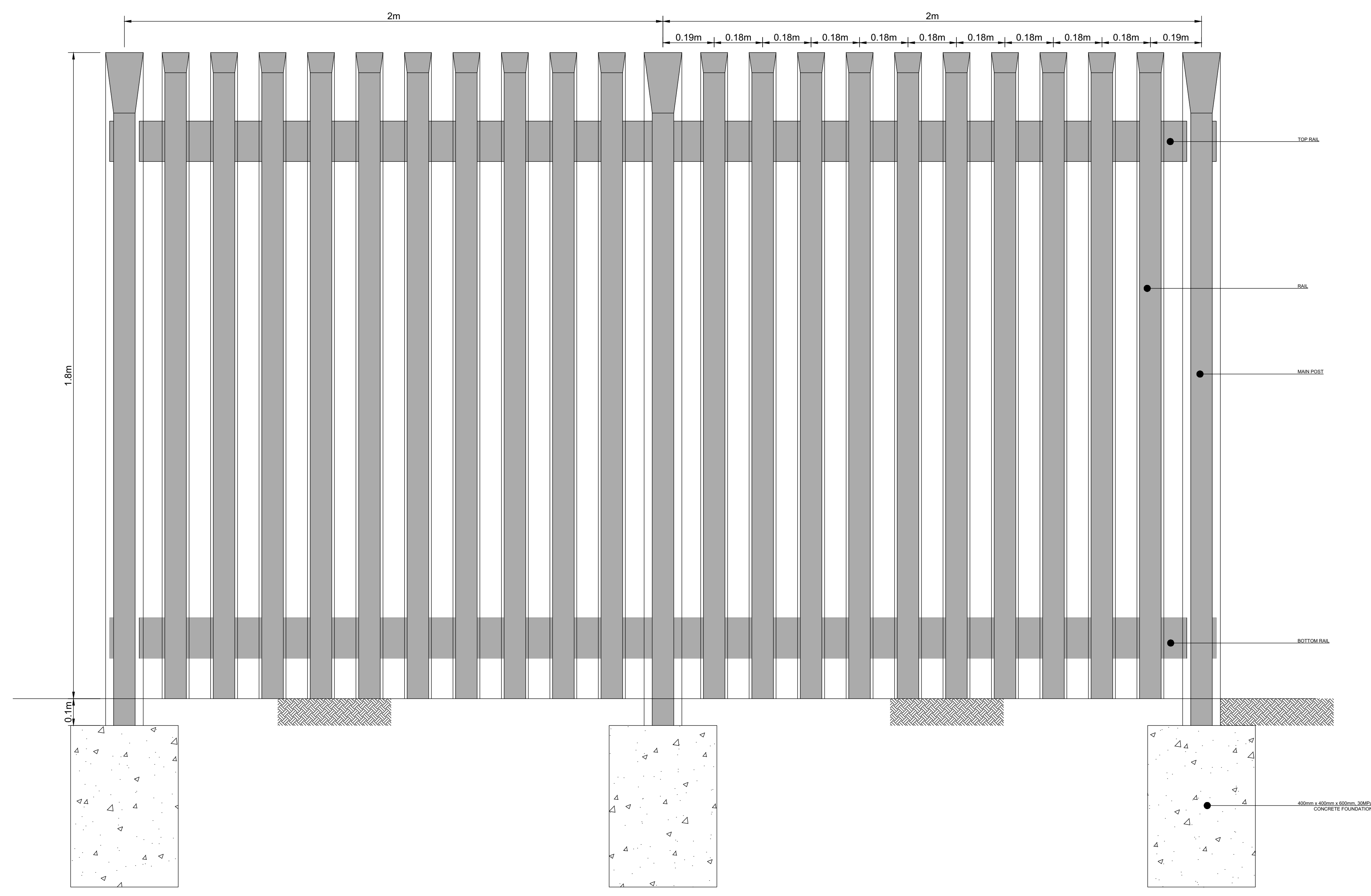
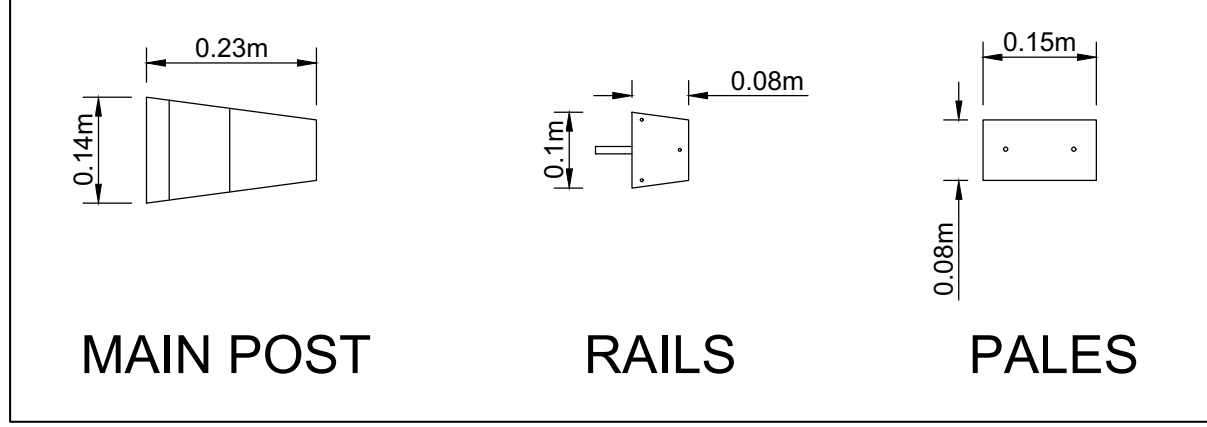

TYPICAL ELEVATION: HEAVY DUTY CONCRETE PALISADE
SCALE 1:10

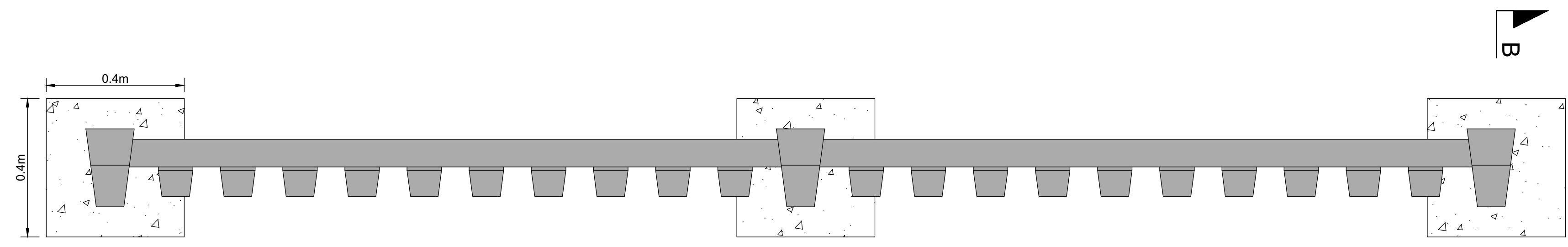

PLAN LAYOUT
SCALE 1:10

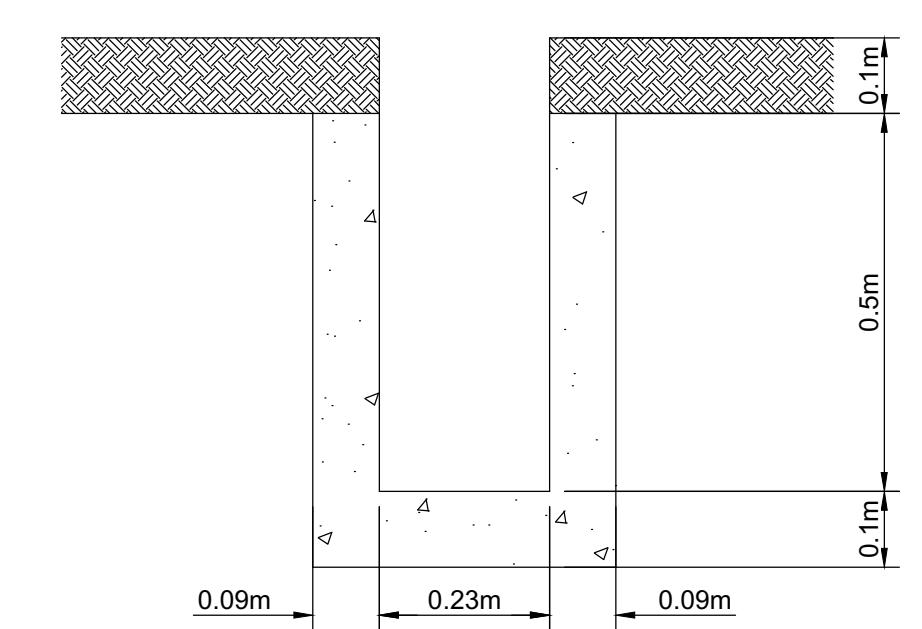

SECTION B-B
SCALE 1:10

ISSUED FOR TENDER		DESIGNED BY ATT	CAPRICORN DISTRICT MUNICIPALITY CAPRICORN DISTRICT MUNICIPALITY P.O. BOX 4100 POLOKWANE 0699	SADC PROJECT CONSULTING & ORBITALS TRADING PROJECT JV UNIT 1 TYBACT PLACE YORK HOUSE WAERFALL PARK BEKKER ROAD MIDRAND 1685	CLIENT CAPRICORN DISTRICT MUNICIPALITY	ISSUED DATE JUNE 2022	SHEET 1 OF 1
SCALE ON REDUCED DRAWING 0 0.01 0.02 0.03 0.04 0.05 0.06 0.07 0.08m		CHECKED BY ATT			PROJECT NAIRIN VILLAGE WATER SUPPLY	DRAWING SIZE A1	SCALE 1:10
No	DATE	CONSULT	DIR	CONSULTING ENGINEER	DATE	DISCIPLINE WATER	DRAWING NUMBER NAIR-STD-09
DRAWING TITLE CONCRETE PALISADE FENCE						CONSULTANTS PROJECT NUMBER ORB-NAIR-W74/2020/2021	REV 0

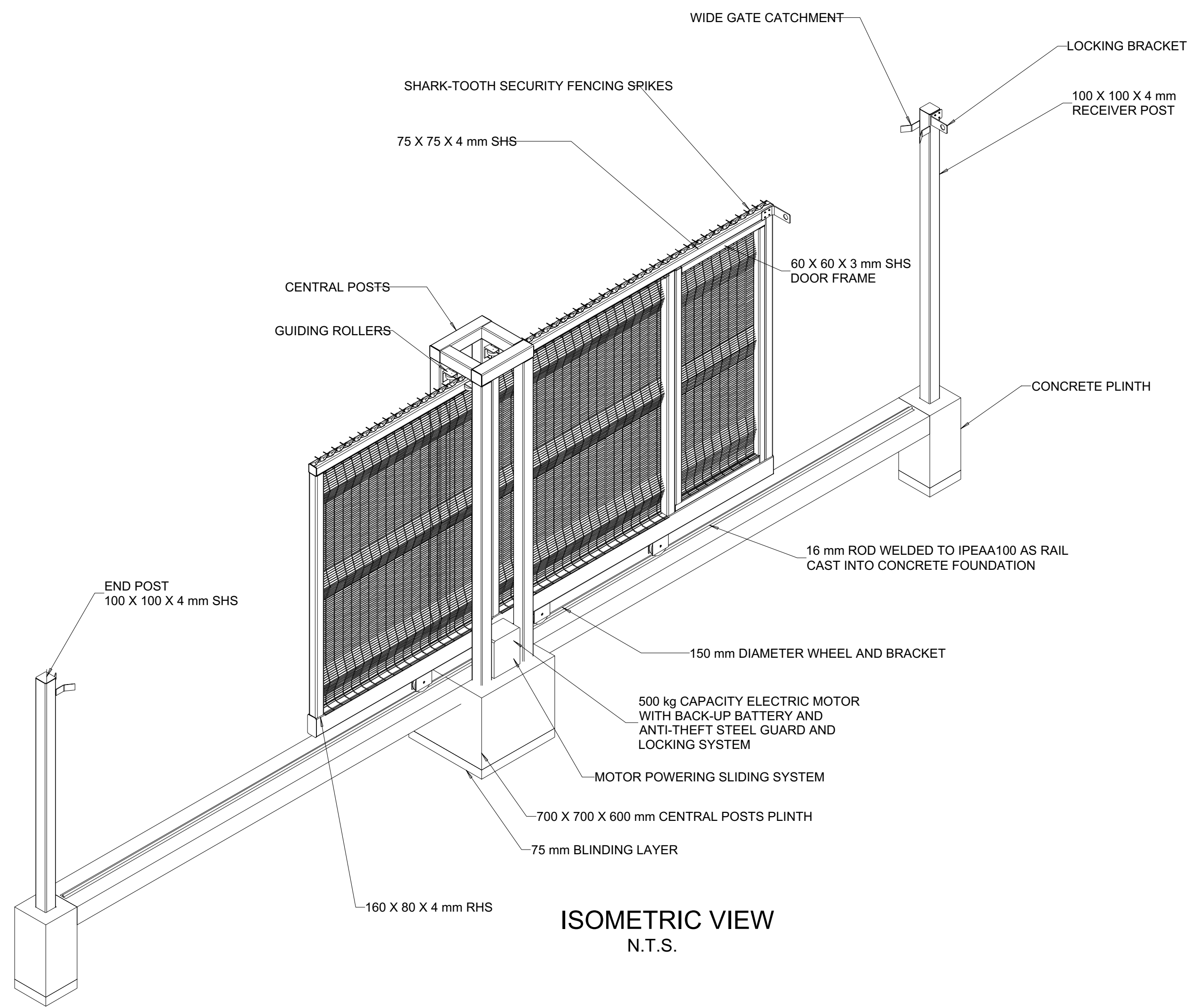

ISOMETRIC VIEW
N.T.S.

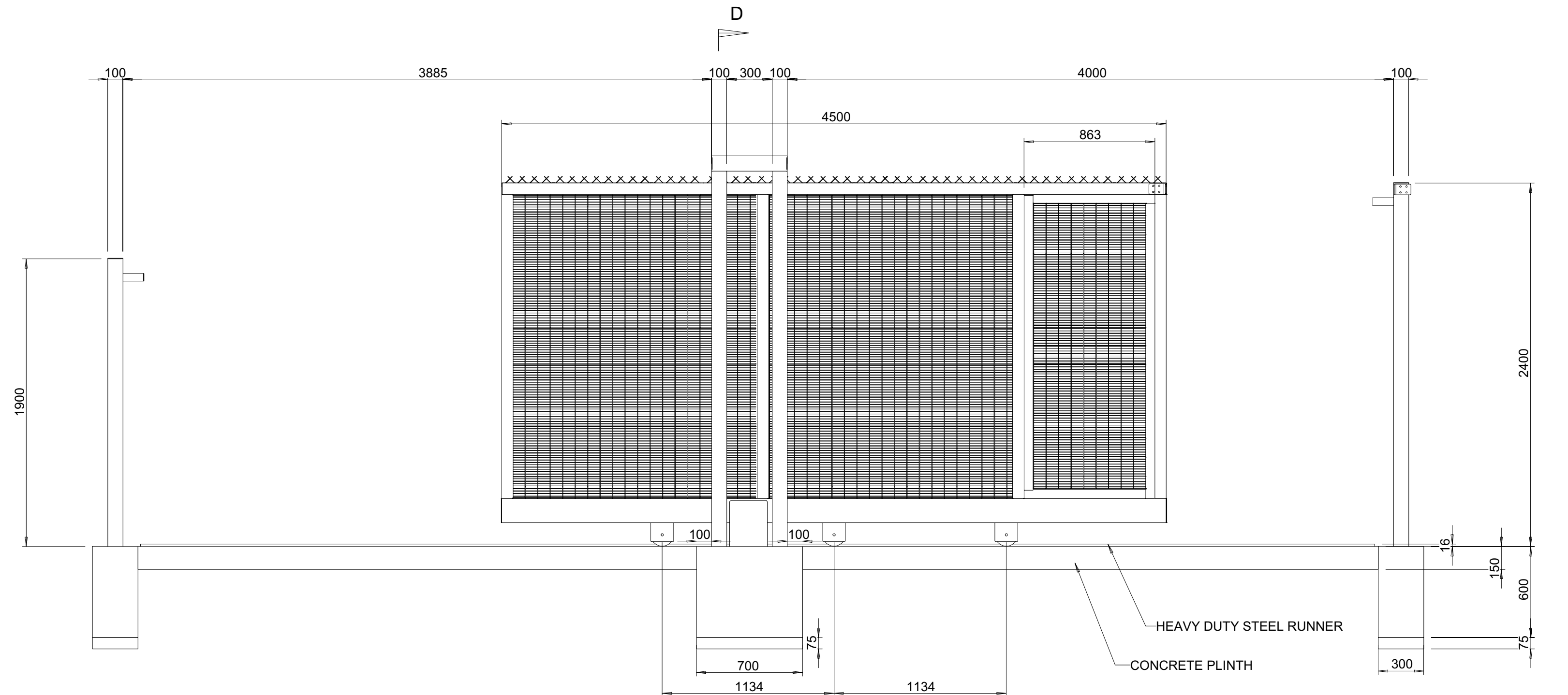

ELEVATION
1:25

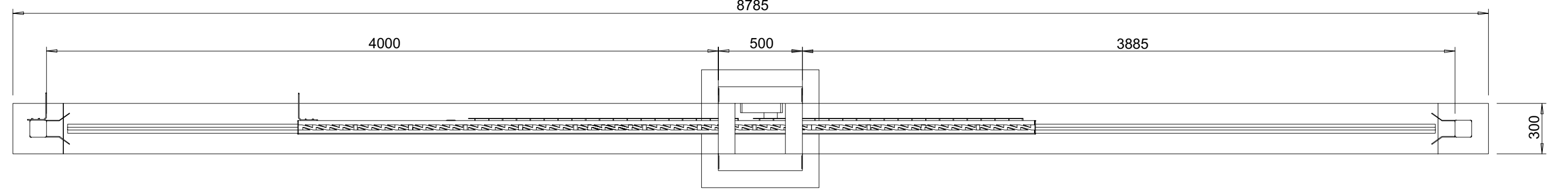

PLAN VIEW
1:25

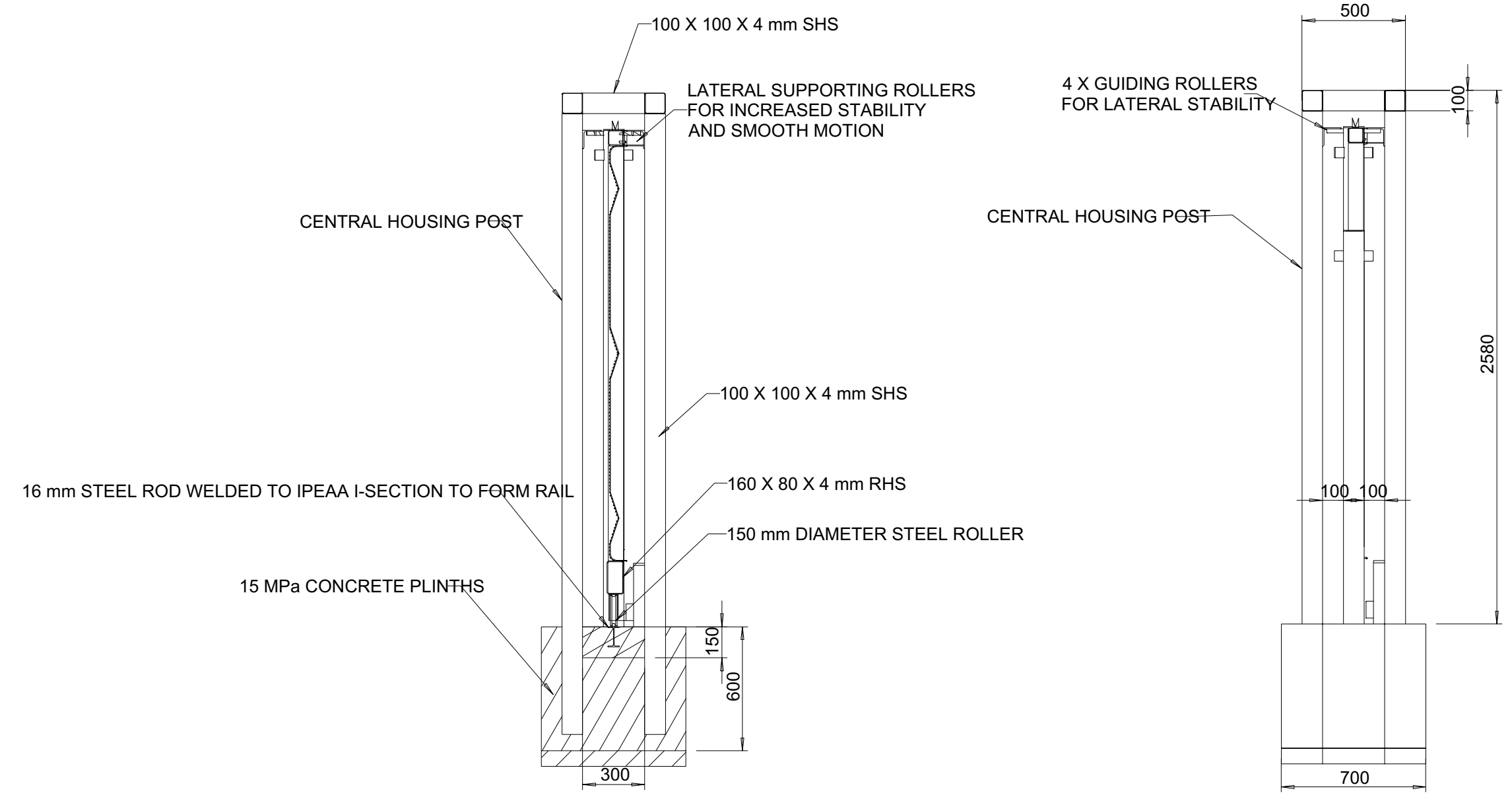

SECTION D
1:25

ELEVATION
1:25

ISSUED FOR TENDER		DESIGNED BY ATT	ATT	CAPRICORN DISTRICT MUNICIPALITY CAPRICORN DISTRICT MUNICIPALITY P.O. BOX 4100 POLOKWANE 0699	SADC PROJECT CONSULTING & ORBITALS TRADING PROJECT JV UNIT 1 TYBACT PLACE YORK HOUSE WAERFALL PARK BEKKER ROAD MIDRAND 1685	CLIENT CAPRICORN DISTRICT MUNICIPALITY	ISSUED DATE JUNE 2022	SHEET 1 OF 1
CHECKED BY ATT		CHECKED BY ATT	ATT			PROJECT NAIRIN VILLAGE WATER SUPPLY	DRAWING SIZE A1	SCALE AS SHOWN
DRAWN BY N.S.		DRAWN BY N.S.	N.S.			DISCIPLINE WATER	CONSULTANTS PROJECT NUMBER ORB-NAIR-W74/2020/2021	DRAWING NUMBER NAIR-STD-10
No	DATE	CONSULT	DIR	SCALE ON REDUCED DRAWING		DRAWING TITLE STEEL SLIDING GATE(4.5m)		

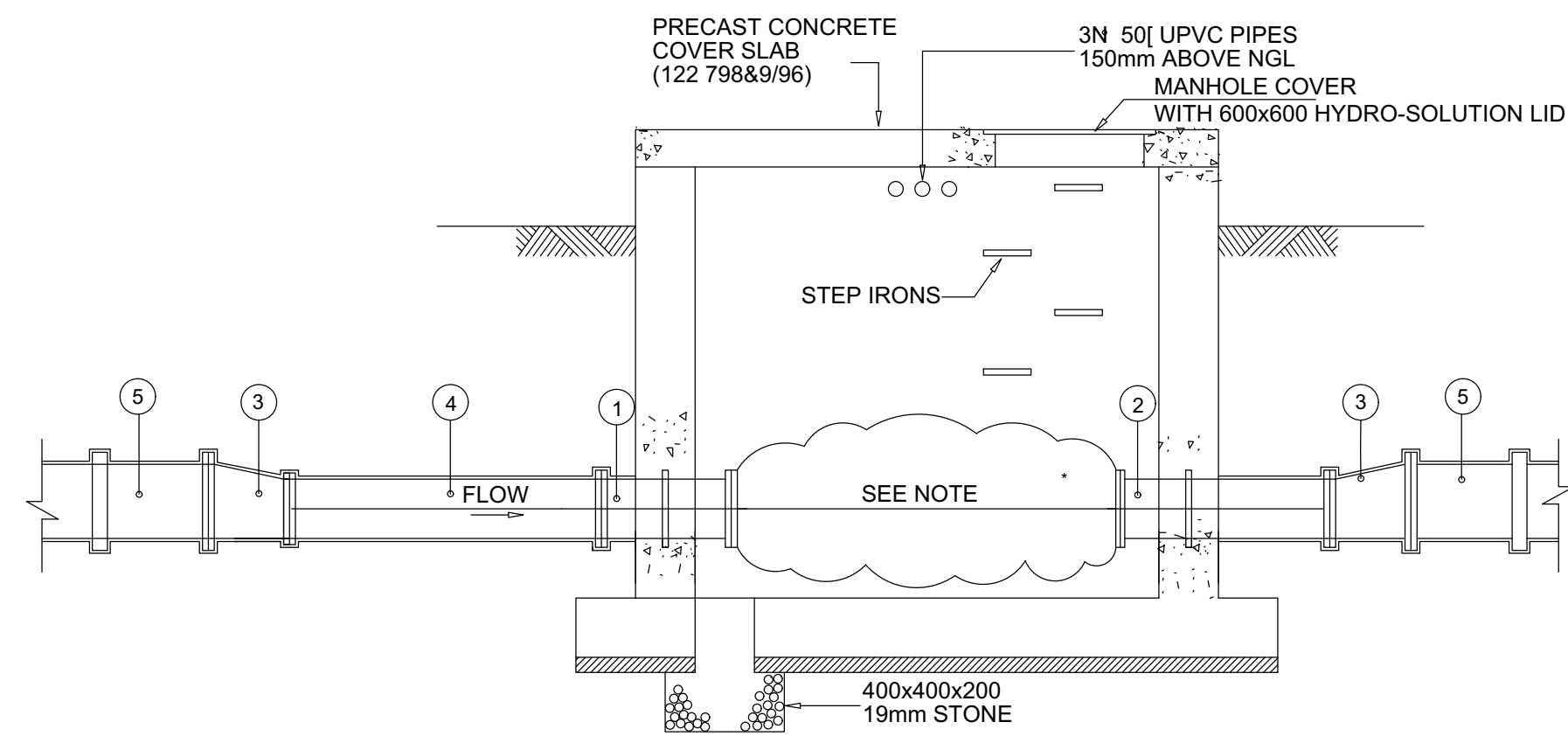

SECTION A - A
SCALE 1:20

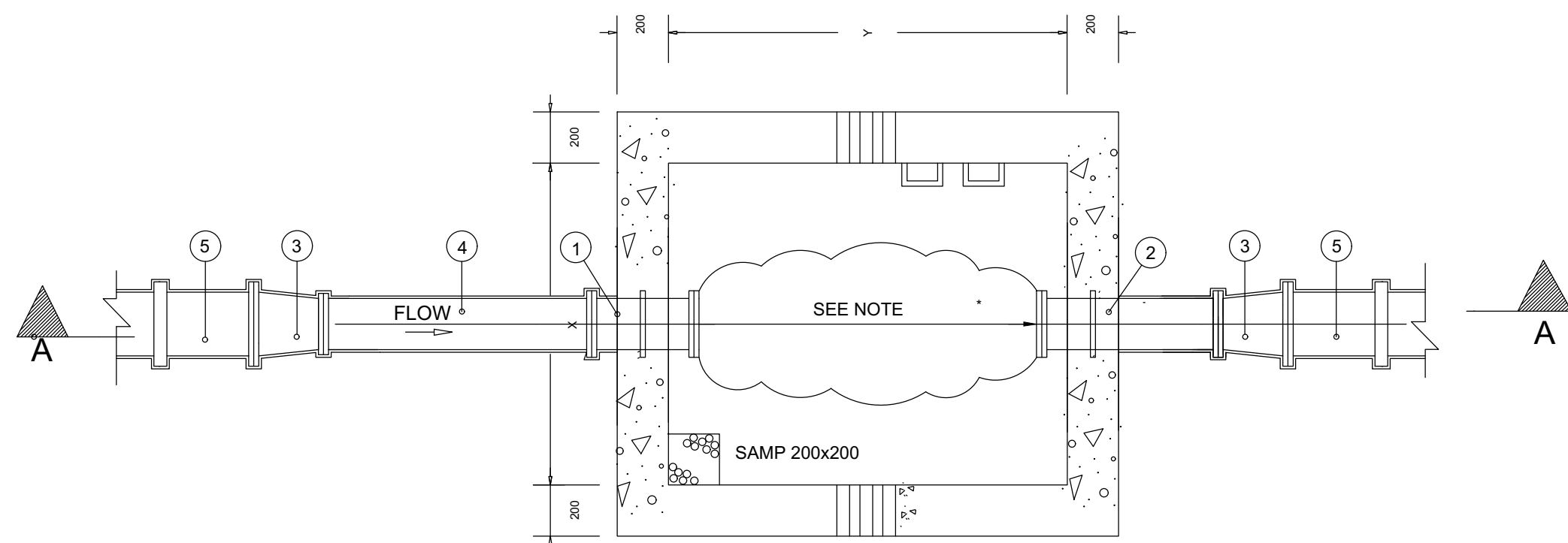

PLAN
SCALE 1:20
DETAIL OF METER BOX

CONTROL VALVE MANHOLES			
TYPE OF MANHOLE	INTERNAL DIMENSIONS(X&Y)	COVER SLAB	PIPE WORK
A	1260x1860	TYPE V.A	SEE TABLE
B	1260x3500	TYPE V.E	SEE TABLE
C	1260x2500	TYPE V.F	SEE TABLE

* - SEE DRAWINGS 140108-C-P-DP004 FOR COVER SLABS

NOTE:
THE CONSTRUCTION OF THE CONTROL VALVE MANHOLES WILL BE PART OF THE PIPELINE CONTRACT AND WILL INCLUDE THE VALVE BOX, MANHOLE COVERS AND PIPE SECTIONS WITH ANCHOR FLANGES AS SHOWN ON THE DRAWINGS. * VALVES, FITTINGS AND PIPEWORK WILL BE MEASURED SEPERATELY.

TABLE OF SPECIAL PIPES AND VALVES					
ITEM No	No. OFF	I.D.	MATERIAL	SCETCH	DESCRIPTION
1	1	200/150	STEEL (GR B 4.5mm THICK)		FLANGED BOTH SIDES WITH PADDLE FLANGE
		80/65/50			
2	1	200/150	STEEL (GR B 4.5mm THICK)		FLANGED BOTH SIDES WITH PADDLE FLANGE
		80/65/50			
3	2	350x200	STEEL (GR B 4.5mm THICK)		REDUCER FLANGE BOTH SIDES
		300x200			
		250x150			
		200x150			
		160x80			
		110x65			
4	1	200	STEEL (GR B 4.5mm THICK)		FLANGE BOTH SIDES
		150			
		80/65/50			
5	2	200	STEEL (GR B 4.5mm THICK)		FLANGED ADAPTOR
		150			
		80			
		65			
		50			

BENDING SCHEDULE												
Refer To - S452 B2										Draw Ref. No. 01		
Project										Date		
Section CONTROL VALVE MANHOLES										Drawn		
										Checked		
Member	Mark	Type	Number In Each	Total Number	Length	Weight	Code	A	B	C	D	E/R
BARS AS PER MANHOLE												
MANHOLE TYPE A	01	Y10	16	16	2150		35	1900				
	02	Y10	16	16	2400		55	130	120	1900	120	
	A03	Y10	13	13	2750		35	2500				
	A04	Y10	13	13	3000		55	130	120	2500	120	
	05	Y10	2	2	900		83	250	90	250		
	06	Y10	36	36	2400		38	1150	120			
	07	Y10	72	72	1650		34	1500				
	08	Y10	40	40	1800		35	1550				
	A09	Y10	80	80	1450		34	1330				
	10	R8	4	4	350		85	100	120	50		
MANHOLE TYPE B	01	Y10	24	24	2150		35	1900				
	02	Y10	24	24	2400		55	130	120	1900	120	
	B03	Y10	13	13	4400		35	4150				
	B04	Y10	13	13	4650		55	130	120	4150	120	
	05	Y10	4	4	900		83	250	90	250		
	06	Y10	52	52	2400		38	1150	120			
	07	Y10	104	104	1650		34	1500				
	08	Y10	40	40	1800		35	1550				
	B09	Y10	80	80	2300		34	2160				
	10	R8	8	8	350		85	100	120	50		
MANHOLE TYPE C	01	Y10	19	19	2150		35	1900				
	02	Y10	19	19	2400		55	130	120	1900	120	
	C03	Y10	13	13	3400		35	3150				
	C04	Y10	13	13	3650		55	130	120	3150	120	
	05	Y10	3	3	900		83	250	90	250		
	06	Y10	42	42	2400		38	1150	120			
	07	Y10	84	84	1650		34	1500				
	08	Y10	40	40	1800		35	1550				
	C09	Y10	80	80	1800		34	1660				
	10	R8	6	6	350		85	100	120	50		

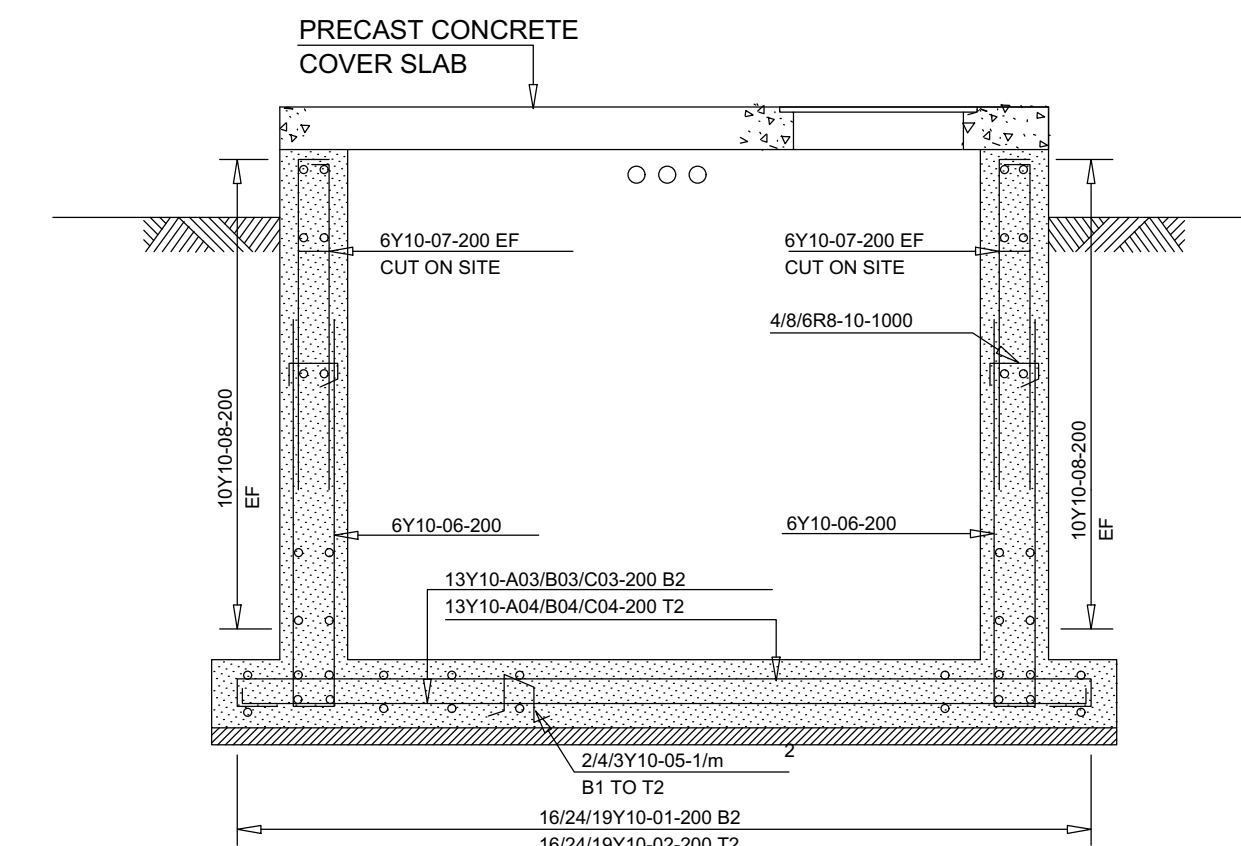

SECTION A - A
SCALE 1:20

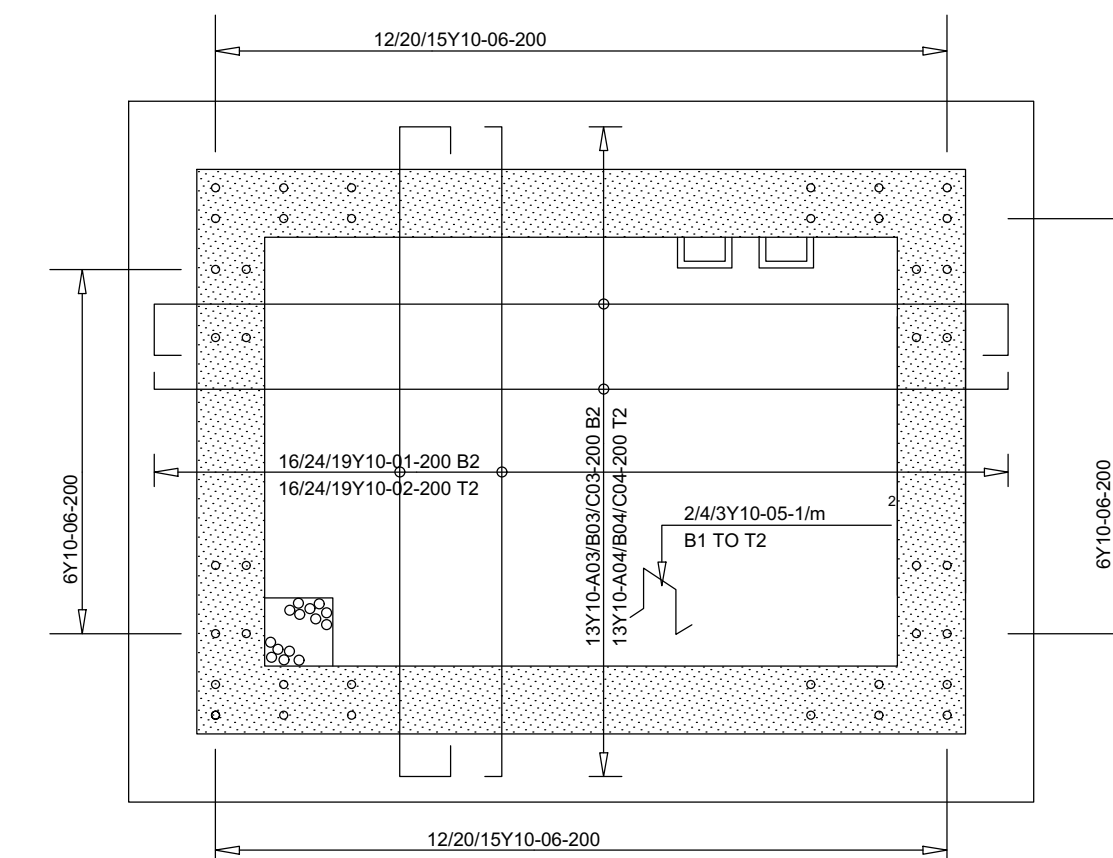

FLOOR SLAB
SCALE 1:20

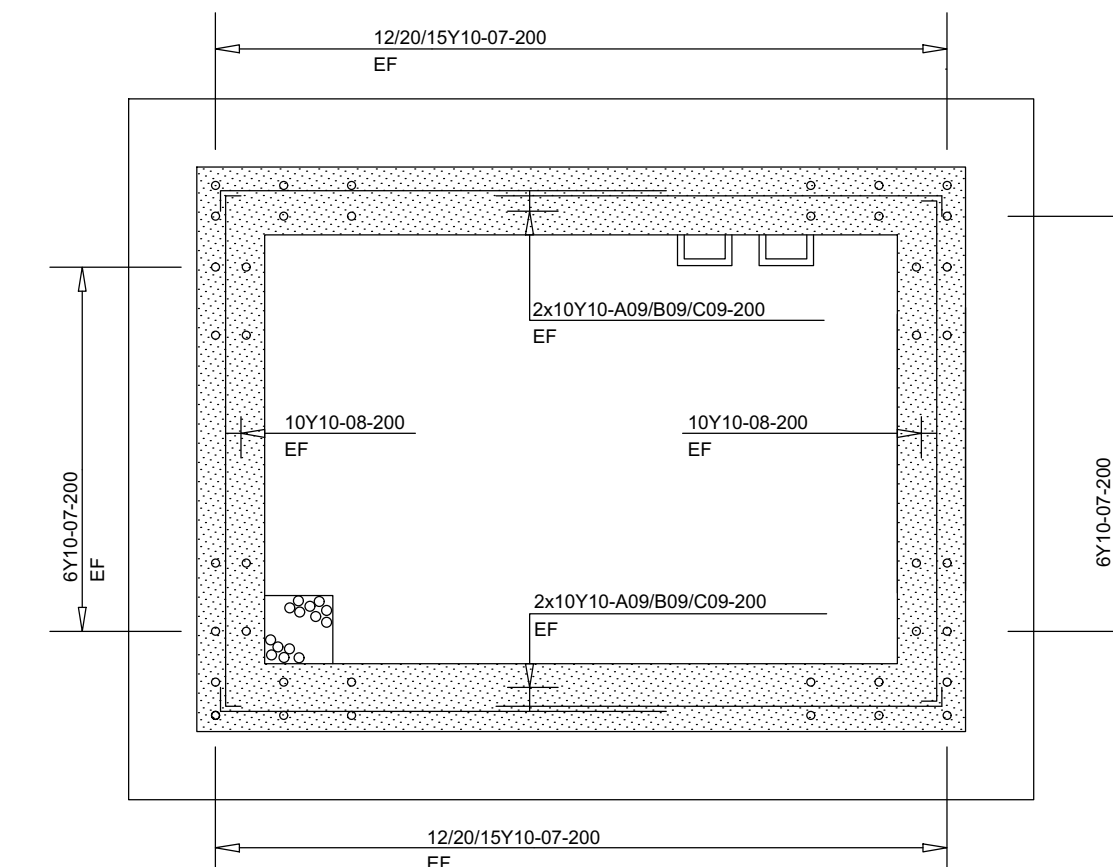

PLAN
SCALE 1:20
DETAIL OF REINFORCEMENT

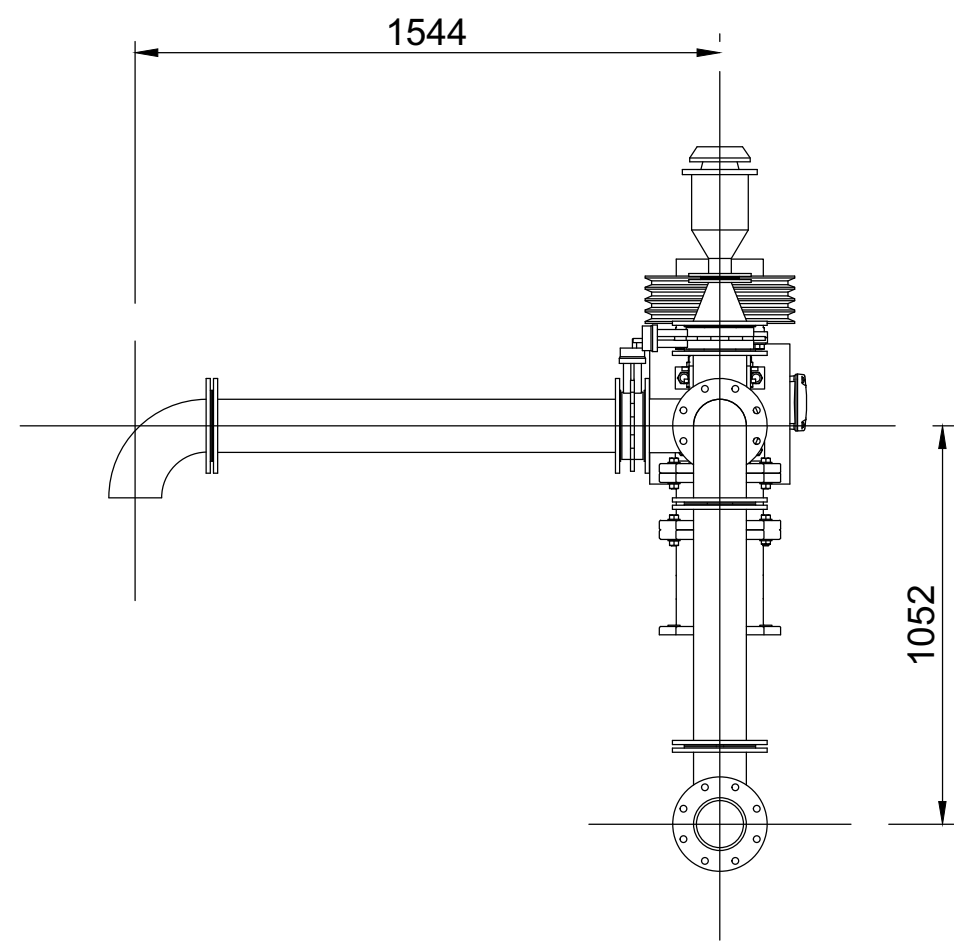

FRONT VIEW

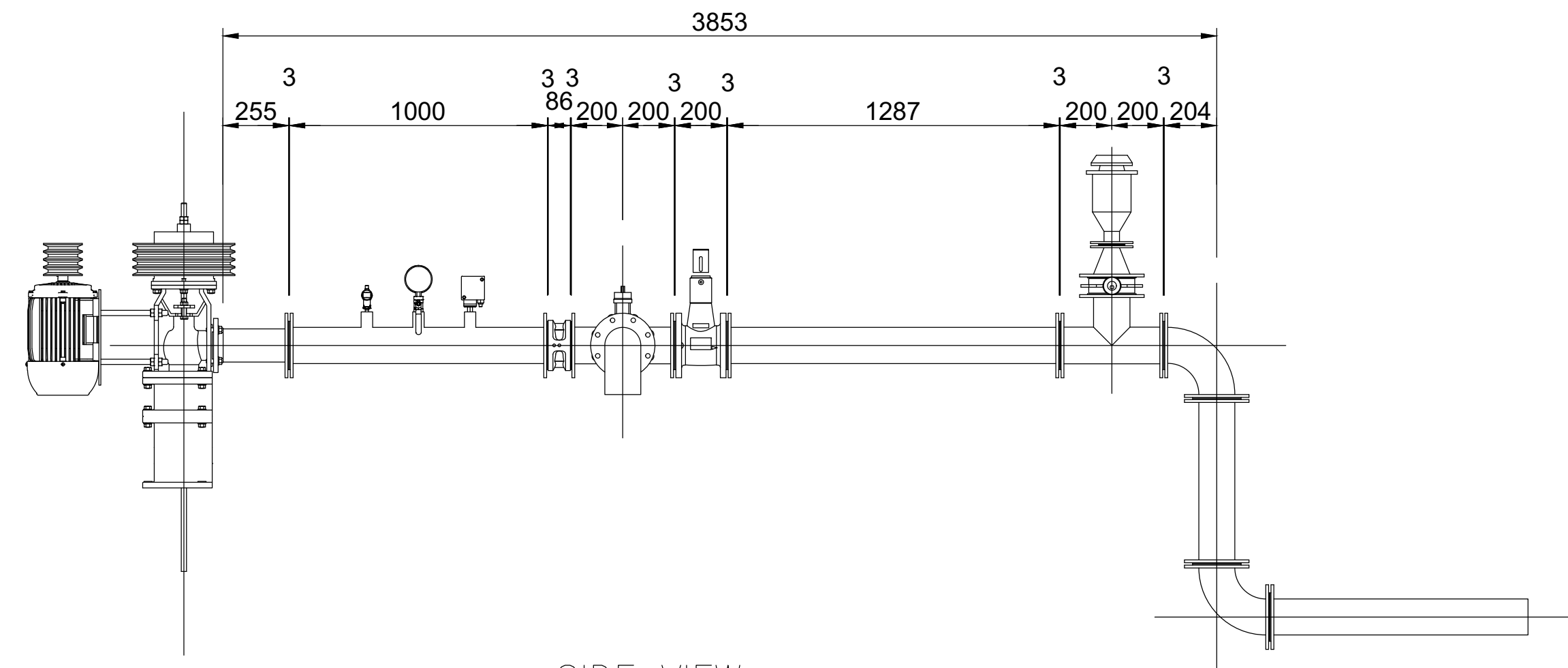

SIDE VIEW

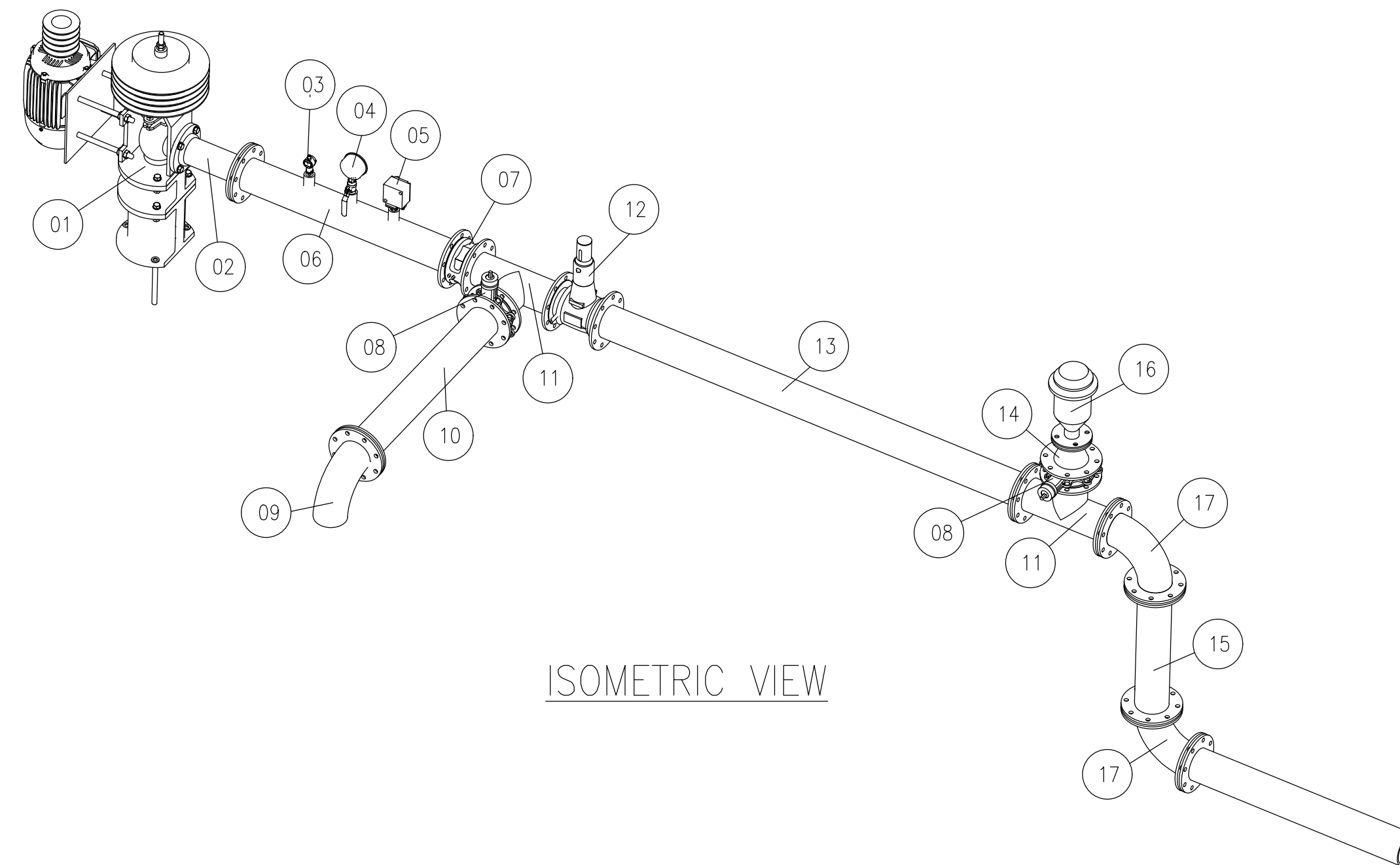

ISOMETRIC VIEW

25 NB SCREW IN SOCKET
WELDED TO PIPE

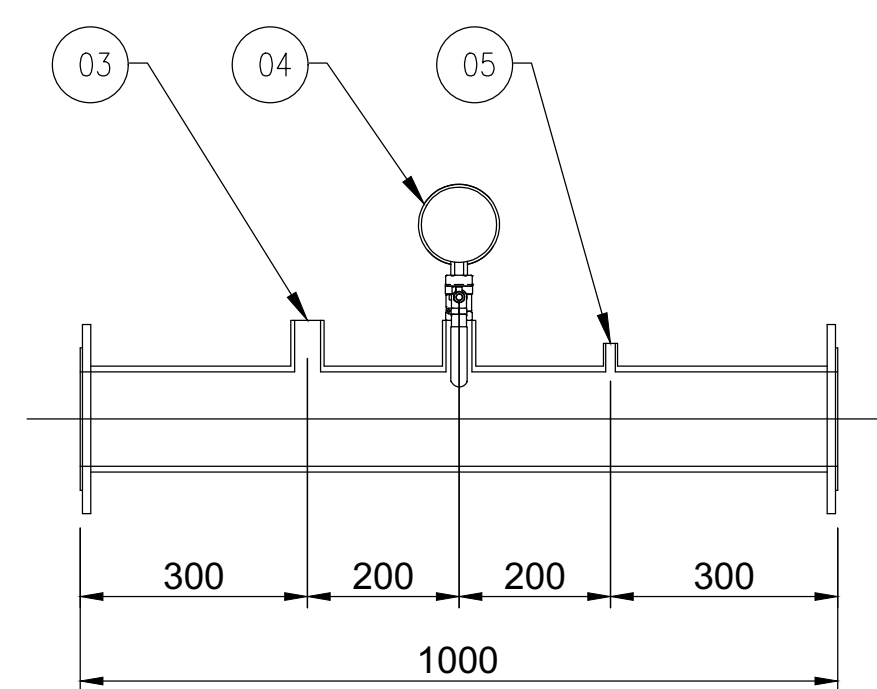

DETAIL VIEW ITEM 06

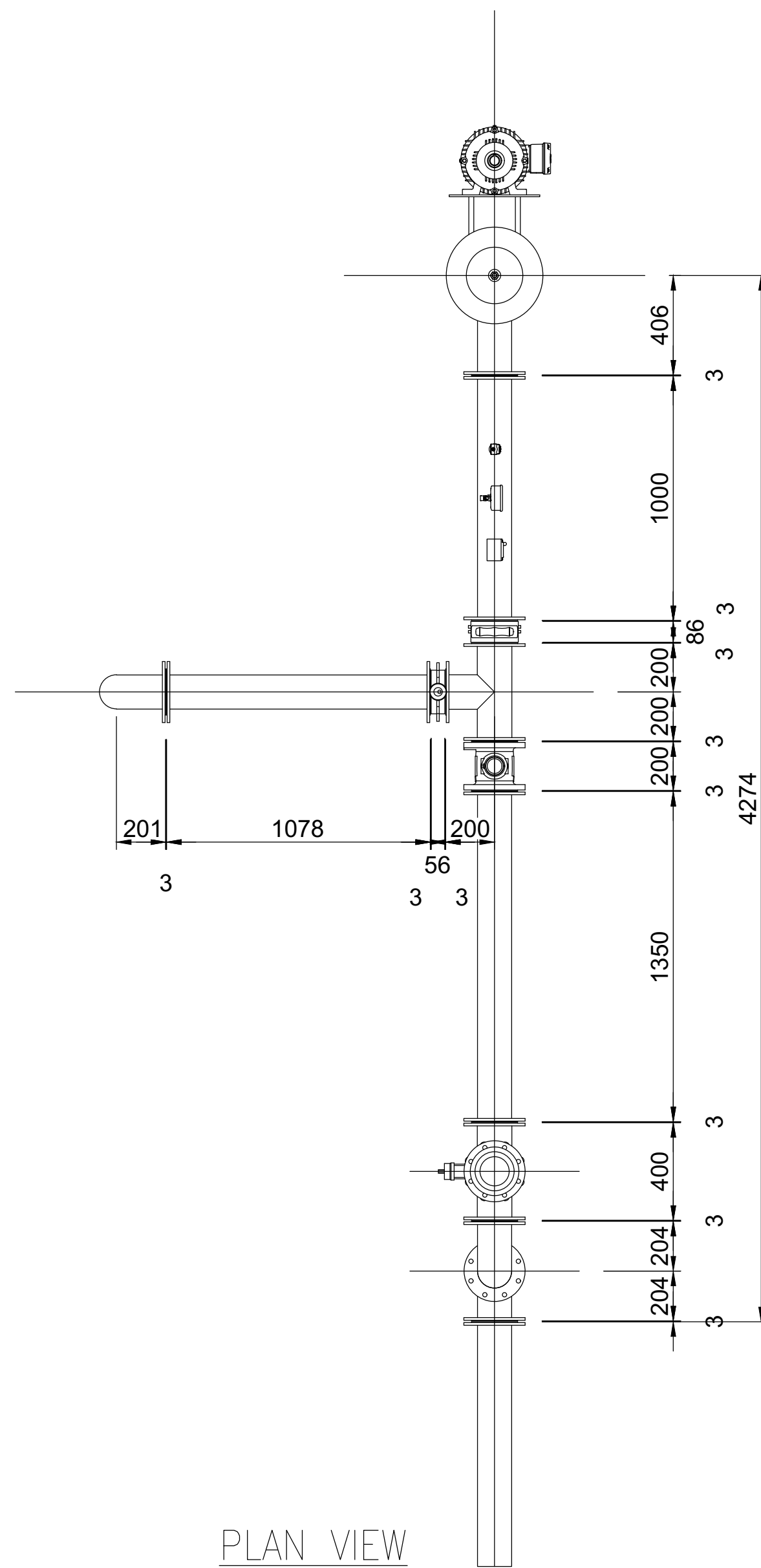

PLAN VIEW

MATERIAL LIST ABOVE PUMP MANIFOLD				
ITEM No	No. OFF	DESCRIPTION	I.D.(in mm)	COMMENT
1	1	TYP MONO PUMP		OR SIMILAR APPROVED
2	1	SPECIAL CONNECTION	80	
3	1	BSP SOCKET	25	
4	1	BSP SOCKET WITH BALL VALVE	25	GLYCERINE PRESSURE GAUGE 0-1600 KPA 304.55 BALL VALVE
5	1	NPT SOCKET	25	
6	1	SPECIAL ITEM DETAIL	80	
7	1	NON RETURN VALVE	80	WAFER TYPE SPRING LOADED
8	2	BUTTERFLY VALVE	80	
9	1	90° SHORT RADIUS BEND FLANGED ONE SIDE	80	
10	1	PIPE	80	
11	2	T-PIECE FLANGED	80	
12	1	GATE VALVE FLANGED	80	RSV TYPE
13	1	PIPE	80	
14	1	CONCENTRIC REDUCER	80 - 50	
15	1	PIPE	80	
16	1	AIR RELIEF VALVE	80	ARI D46 MIN PN16
17	2	90° SHORT RADIUS BEND FLANGE	80	

NOTE FOR ALL VALVES
SIZE AND TYPE FROM WATER SURGE REQUIREMENT TAKES PREFERENCE

GENERAL NOTES

- 1) ALL AMBIGUITIES ON DRAWING MUST BE REPORTED TO THE DESIGN ENGINEER BEFORE COMMENCEMENT OF CONSTRUCTION.
- 2) PRIOR TO ANY WORK BEING DONE, A SURVEY OF THE EXISTING GROUND WORK, TO BE PROVIDED TO THE ENGINEER BY THE CONTRACTOR.
- 3) ALL WORK MUST BE DONE IN ACCORDANCE WITH THE STANDARD SANS 1200 SPECIFICATION AND THIS PROJECT'S APPLICABLE CONTRACT DOCUMENTATION.

NB!!

- 1) FITTING SIZES MAY BE ALTERED AND REARRANGED FOR DIFFERENT BOREHOLE DELIVERY MAIN AS DETERMINED ON SITE BY THE ENGINEER.

ISSUED FOR TENDER PURPOSES		DESIGNED BY: ATT	CAPRICORN DISTRICT MUNICIPALITY	SADC PROJECT CONSULTING & ORBITALS	CLIENT: CAPRICORN DISTRICT MUNICIPALITY	ISSUED DATE: JULY 2022	SHEET 1 OF 1
SCALE ON REDUCED DRAWING		CHECKED BY: ATT	CAPRICORN DISTRICT MUNICIPALITY	TRADING PROJECT JV	PROJECT: NAIRIN VILLAGE WATER SUPPLY	DRAWING SIZE: A1	SCALE: AS SHOWN
0 0.01 0.02 0.03 0.04 0.05 0.07 0.09m		DRAWN BY: N.S.	P.O. BOX 4100	UNIT 1 TYBACT PLACE	DISCIPLINE: WATER	CONSULTANTS PROJECT NUMBER: ORB-NAIR-W74/2020/2021	DRAWING NUMBER: NAIR-STD-12
No. DATE CONSULT. DIR.		CHECKED BY: ATT	POLOKWANE 0699	YORK HOUSE WAERFALL PARK	DRAWING TITLE: BOREHOLE PUMP STATION MANIFOLD TYPICAL LAYOUT	REV: 0	
			CAPRICORN DISTRICT MUNICIPALITY	BEKKER ROAD MIDRAND 1685	CONSULTING ENGINEER: _____ DATE: _____		